



ARCHIVED - Archiving Content

Archived Content

Information identified as archived is provided for reference, research or recordkeeping purposes. It is not subject to the Government of Canada Web Standards and has not been altered or updated since it was archived. Please contact us to request a format other than those available.

ARCHIVÉE - Contenu archivé

Contenu archivé

L'information dont il est indiqué qu'elle est archivée est fournie à des fins de référence, de recherche ou de tenue de documents. Elle n'est pas assujettie aux normes Web du gouvernement du Canada et elle n'a pas été modifiée ou mise à jour depuis son archivage. Pour obtenir cette information dans un autre format, veuillez communiquer avec nous.

This document is archival in nature and is intended for those who wish to consult archival documents made available from the collection of Public Safety Canada.

Some of these documents are available in only one official language. Translation, to be provided by Public Safety Canada, is available upon request.

Le présent document a une valeur archivistique et fait partie des documents d'archives rendus disponibles par Sécurité publique Canada à ceux qui souhaitent consulter ces documents issus de sa collection.

Certains de ces documents ne sont disponibles que dans une langue officielle. Sécurité publique Canada fournira une traduction sur demande.

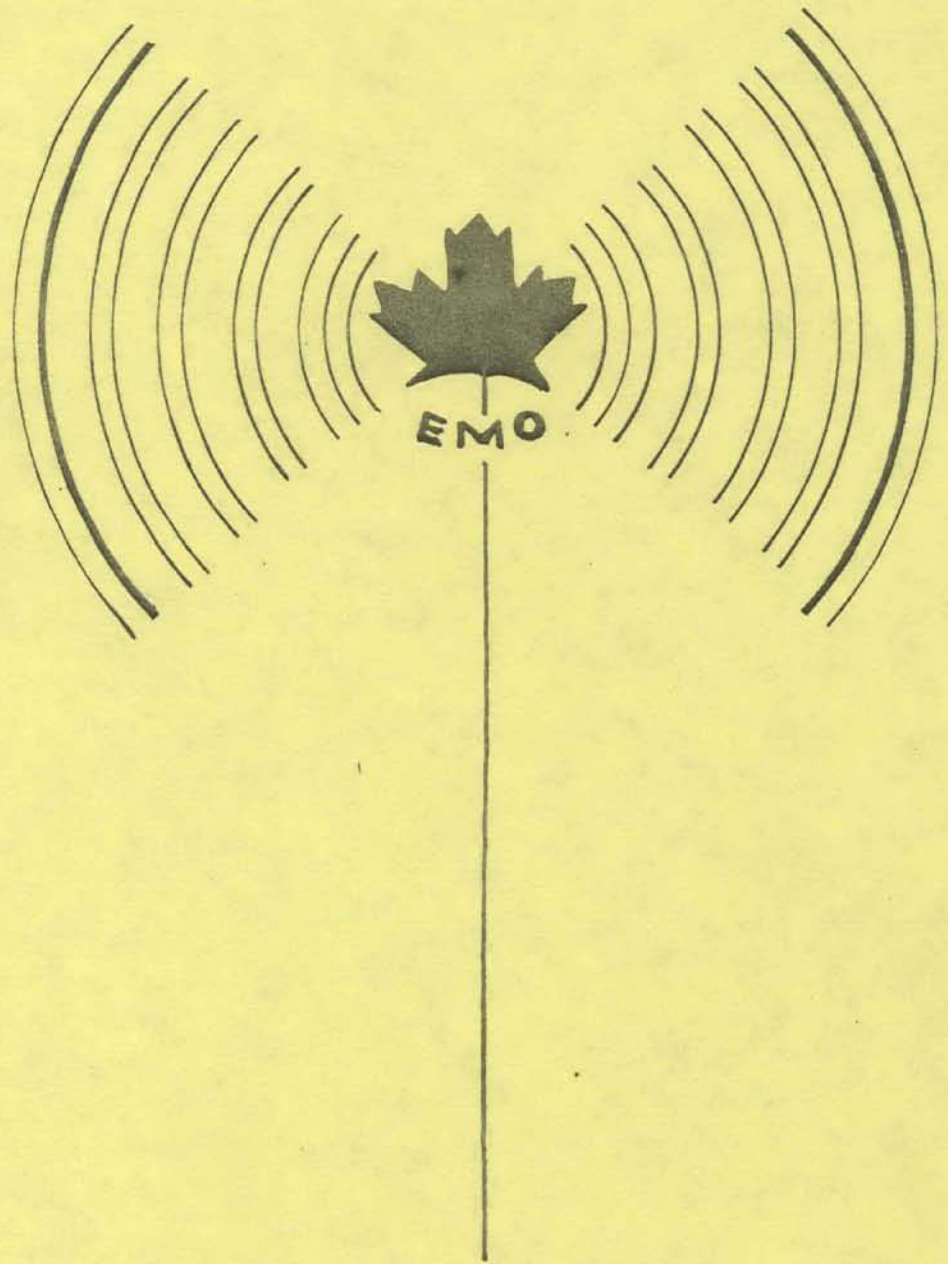

Canada EMO
WORKING GROUP
on the
AMATEUR EXPERIMENTAL SERVICE
in
EMERGENCY COMMUNICATIONS
May 16-17, 1973

HV 551.5
.c2
W65
1973



WORKING GROUP REPORT

Copyright of this document does not belong to the Crown.
Proper authorization must be obtained from the author for
any intended use.
Les droits d'auteur du présent document n'appartiennent
pas à l'Etat. Toute utilisation du contenu du présent
document doit être approuvée préalablement par l'auteur.

ISSUED BY CANADA EMERGENCY MEASURES ORGANIZATION
DEPARTMENT OF NATIONAL DEFENCE

COMPILED AND EDITED BY THE
EMERGENCY PREPAREDNESS DIVISION, SECURITY SERVICES BRANCH
DEPARTMENT OF SUPPLY AND SERVICES

WORKING GROUP CONVENOR:
PAUL E. AMYOT

WORKING GROUP SECRETARY:
DOUGLAS R. BURRILL

OTTAWA

JUNE 1973

FOREWORD

There are approximately 13,000 licensed Amateur radio operators in Canada.

The minimum qualification required for an Amateur Certificate is a knowledge of radio theory, operation of equipment, and Morse code at 10 wpm. Seventy percent of these Amateurs are qualified in a higher grade of radio technology and have a Morse proficiency of 15 wpm or more.

The communications capability extends from a few miles for mobile very high frequency (VHF) equipment to world-wide coverage with high frequency (HF) equipment, varying from a few dollars for homemade equipment or adapted surplus commercial equipment to commercially-sold amateur equipment costing many hundreds of dollars.

A 1968 survey revealed that 40% of Ontario amateurs had commercially-made equipment valued at \$1,000 or more. Applying this to the whole number of licensed amateurs, it means that there is at least a \$5.2 million communications system of a commercial quality available for emergency use.

The Amateurs are located in many diverse locations from coast-to-coast where there are no other communications facilities.

This versatile communication resource should not be overlooked when a back-up to official emergency communications is being considered. As yet, there is no formal, official, national recognition of the capability of communication of the Amateur Experimental Service in Canada.

With the co-operation of interested federal departments, Canada EMO and Canadian Amateur organizations, this valuable resource of communications equipment, operating personnel and expertise could be developed into a "Canadian Amateur Radio Emergency Service" on a national basis to serve in times of crisis as it is needed.

I N D E X

WORKING GROUP ON THE ROLE OF AMATEUR RADIO
IN EMERGENCY COMMUNICATIONS

	<u>Page No.</u>
Introduction	(v)
The Working Group and Observers	(vii)
Topics for Discussion	(x)
Recommendations and Conclusions	1
Summary of the Discussions	5
 <u>ANNEXES</u>	
 <u>PART I - AMATEUR RADIO SERVICE REPEATERS</u>	
Brief on Emergency Communications and the Amateur Experimental Service in New Brunswick as presented to the Cabinet of the Province of New Brunswick	1
- F. H. Ryder, B. Sc., M. Eng., (M)IEE, C. Eng. FIEE (VELAIL), N.B. Power Commission	
The Use of Amateur Repeaters in Peacetime Emergencies	2
- A. E. Blick, Pres. Canadian Amateur Radio Federation, Inc. Comm. Officer, Frontenac-Kingston Co. EMO (Staff, Royal Military College, Kingston)	
List of Repeaters in Canada and Northern United States	3
- courtesy ALPHATEXT, Ottawa (Not current; only to show extent)	
Amateur Civil Defense Responsibility	4
- extract from "73" Magazine, April 1973 by W2NSD/1	
The Florida Repeater Mess is Looking Up	5
- by W4RLG in "73" Magazine for April 1972 (illustrates why repeater frequency planning on a national scale is becoming a necessity).	
National Standardization of Repeater Frequencies	5A
- C. A. (Sonny) Gray, VE3BTS Ottawa Repeater Group	

PART II - THE AMATEUR SERVICE IN EMERGENCY COMMUNICATIONS
PLANNING

"Who's in Charge"	6
- Frank Purdy (YE3FPF), Toronto, Issue 2, 1973, edition of "The Ontario Amateur",	
Extracts from "A Guide to Civil Emergency Planning for Municipalities"	7
- Canada EMO	
Extracts from the Radio Act and the Radio Regulations Related to Emergency Communications and the Use of Amateur Radio	8
"The Use of Peacetime Amateur Band Frequencies for Civil Emergency Operations in Wartime"	9
- Canada EMO Bulletin No. 7	
"Use of General Radio Service (GRS) Equipment for Emergency Operations"	10
- Canada EMO Bulletin No. 8	
United States Military Amateur Radio Service (MARS)	11
- U.S. Official Publication and "QST" Magazine, May 1973	
Extracts from the United States Booklet "Radio Amateur Civil Emergency Service (RACES)"	12
FCC Docket 19723, Notice of Inquiry, April 18, 1973	13
- Petitions to FCC to expand VHF frequencies available for RACES purposes. (Some of these conflict with Canada EMO wartime frequency allocations.)	

PART III - TYPICAL EMERGENCY COMMUNICATIONS PLANS INVOLVING
THE AMATEUR RADIO SERVICE

Amateur Radio in British Columbia Civil Defence	14
- Owens Evans, VE7QT	
Manual of Peacetime Operations for Alberta EMO Amateur Radio Net	15

The Use of Amateur Radio in the Saskatchewan EMO Communications Plan	16
- Bill Parker, VE5CU	
Extract from the Saskatoon EMO Communications Plan	17
- Bill Parker, VE5CU	
A Model Plan for the Involvement of Amateurs in a Local Emergency Measures Organization	18
- Art Blick, VE3AHU	
 <u>PART IV - RECENT USE OF THE AMATEUR EXPERIMENTAL SERVICE IN EMERGENCY COMMUNICATIONS</u>	
Communications Service Provided to the Emergency Measures Organization During the 1973 St-John River Flood	19
- F. Ryder, VE1AIL	
A report on Amateur Participation in the St-John River Flood, May 1973	20
- Lorne Titus, VE1IN	
"The Managua Earthquake"	21
-Ron Belleville, VE3AUM	
"Operation Crash" - Saskatoon Plan for a Hospital Disaster Exercise	22
-Bill Parker, VE5CU	
 <u>PART V - WORKING GROUP AND OTHER RELATED PAPERS</u>	
Designation of Amateur Frequencies for Peacetime Emergency Use	23
-Steve Chisholm, VE4A1	
Emergency Operations Extract from FCC Amateur Regulations	24
Power Sources for Emergency Communications	25
- Ken Rolison, P. Eng., VE3CRL	
Notes Regarding Radio Interference From Power Lines	26
- Ken Rolison, P. Eng., VE3CRL	
Co-operation Between the Amateur Experimental Service and Emergency Agencies	27

Amateur Radio in Canada; Its Organization and Role in Emergency Operations	28
- Doug Burrill, VE3CDC	
The Canadian Amateur Radio Federation - A Short History	29
- Art Blick, VE3AHU	
The "Teague" Bill, U.S. Congress, House of Representatives' Bill HR3516 to require that radio and television receivers meet certain technical standards for filtering and inter- ference, including all interference from amateur stations.	30
A Recommended Message Form for Canadian Amateurs	31
- Art Blick, VE3AHU	
Extracts from "The Effects of the Electro-Magnet Pulse Generated by Nuclear Weapons", published by the U.S. Defense Civil Preparedness Agency	32

INTRODUCTION

In February 1973, the Canada Emergency Measures Organization convened an Emergency Communications Planning Officers' Conference at the Canada EMO College at Arnprior and one of the topics concerned the role of the Amateur Experimental Service in emergencies. Time did not permit discussion of a number of questions which arose and Mr. J. F. Wallace, the Director-General of Programs and Operations for Canada EMO, asked that a Working Group be convened to discuss these questions and arrive at conclusions which could, if it was deemed advisable, lead to recommendations for action by the appropriate agencies.

The Working Group met at Arnprior on May 16 and 17 and this Report contains an outline of the discussions, the conclusions reached, and the recommendations made to Canada EMO for its action with other government agencies.

The circulation of this Working Group Report is wider than that of the Conference Report, hence the material relevant to the Amateur Experimental Service contained in the Conference Report is also included in this one for the benefit of those who were not on its distribution list.

Other papers pertinent to the Working Group's objectives have also been included.

Papers in Part V describing the use of Amateur radio in the 1973 St. John River flood emergency, the 1972 Managua earthquake and an emergency exercise in Saskatoon give good accounts of the communications capability of the Amateur Experimental Service in emergency operations.

A view of the United States Amateur Radio Service involvement in Amateur-sponsored public service activities is expressed in an article from "73" Magazine.

The extent of the use of Amateur VHF and UHF repeaters is emphasized by a directory showing these facilities in Canada and the Northern United States.

By coincidence, the article "Who's In Charge?" in Annex 6 appeared in a Canadian Amateur radio publication just before the matter of delivering urgent traffic to federal departments was considered at the Working Group Meeting. It showed the individual Amateur's initiative in attempting to solve a serious problem in emergency communications. The Working Group has made official recommendations concerning this problem.

The technical papers on interference and emergency power sources are included to show the problems encountered by the Amateur experimenters and the professional expertise available from their ranks to solve them.

The extracts from the manual on "RACES" details the official United States Government involvement with the Amateur Service in that country as does the article in the (U.S.) Military Amateur Radio Service (MARS) from "QST" Magazine.

There is available in Canada a vast reservoir of equipment, technical professional and operating expertise in the Amateur Experimental Service which can be used either as first-line communications or as a back-up system of an extent which can only be realized by those who are familiar with it.

The sophistication of some of the Amateur Experimental Service activities is equivalent to, and in some cases, surpasses commercial development. Electronic and communications companies have for decades been indebted to the individual Amateur experimenter for many of their products and techniques. In Ottawa, for example, a local Amateur controls an Amateur communications satellite, (OSCAR VI) which has been a tremendous success in national, international and intercontinental transmissions. He is currently, along with a handful of other Amateurs, assembling the electronic heart of another satellite to be launched late this year.

A plan is currently being drafted seeking recognition on a national basis of the capability of the Amateur Experimental Service to render assistance to government at all levels when they are faced with crises which require communications. The plan, which is being developed by interested Amateurs, will be presented to Canada EMO for its consideration and action.

WORKING GROUP ON THE ROLE OF
AMATEUR RADIO IN EMERGENCY
May 16-17, 1973 - Arnprior, Ontario

Working Group

Paul Amyot	-	Canada EMO	Ottawa
Ron Belleville	VE3AUM	RCMP Comm.	Ottawa
Art Blick	VE3AHU	Royal Military College	Kingston
Doug Burrill	VE3CDC	DSS (Security Services)	Ottawa
Steve Chisholm	VE4AI	Red River College	Winnipeg
Mike Considine	-	BC Civil Defence	Victoria
A. (Sandy) Gowans	-	EMO Comm Officer	Ottawa
G. A. (Sonny) Gray	VE3BTS	Cdn. Forces Signals	Ottawa
Pierre Massicotte	VE2DEV	Quebec Protection Civile	Quebec
W. H. (Bill) Parker	VE5CU	Ass't Director EMO	Saskatoon
Ken Rolison	VE3CRL	CN Telecommunications	Toronto
J. B. (Jap) Streater	(licensed-no call)	Ontario EMO Comm. Officer	Toronto

Local Observers

Bernard Goyette		Canada EMO	Ottawa
Fred Holcombe		Coordinator, Ottawa Carleton EMO	Ottawa
Doug Lamb	(GRS)	-	Ottawa
Howard Poole	VE3VP	AREC	Ottawa

DOC Telecommunications Regulations Branch

W. T. (Bill) Lanyon	(licensed - no call)		Ottawa
W. J. McCurdy			Ottawa

ADDRESSESTELEPHONE NOS

P. E. Amyot (Convenor) Chief, Communications Planning Canada Emergency Measures Organization Dept. of National Defence Ottawa, Ontario	(613) 992-0659
Ron Belleville VE3AUM Communications Section RCMP Headquarters 1200 Alta Vista Drive Ottawa, Ontario K1A OR2	(613) 993-9735
A. E. Blick, VE3AHU Electrical Engineering Department Royal Military College Kingston, Ontario	(613) 547-7282
D. R. Burrill VE3CDC (Secretary) Emergency Preparedness Division Security Services Branch Dept. of Supply and Services 70 Lyon Street Ottawa, Ontario K1A OS5	(613) 992-8001
S. C. Chisholm VE4A1 Red River College Winnipeg, Manitoba	(204) 786-6273
M. A. Considine B. C. Civil Defence Communications Officer Parliament Bldgs Victoria, B. C.	(604) 387-6616
A. Gowans Communications Officer Ottawa-Carleton Emergency Measures Organization 495 Richmond Road Ottawa	(613) 725-3337
Bernard Goyette c/o Chief, Communications Planning Canada Emergency Measures Organization Dept. of National Defence, Ottawa, Ontario	(613) 992-0659
C. A. Gray VE3BTS 703 Comms. Regt (Res) Wallace House Charlotte and Rideau Ottawa, Ontario	(613) 992-7038

F. F. Holcombe Coordinator, Ottawa-Carleton Emergency Measures Organization 495 Richmond Road, Ottawa, Ontario	(613) 725-3337
Douglas Lamb 22 McLeod Crescent Ottawa, Ontario	(613) 745-7910
W. T. Lanyon (licensed - no call) Telecommunications & Regulations Branch Dept. of Communications 100 Metcalfe Street Ottawa, Ontario	(613) 992-1529
Pierre Massicotte, VE2DEV Chief, Telecommunications Section Protection Civile Québec, P.Q.	(418) 643-3256
W. J. McCurdy Telecommunications Regulations Branch Dept. of Communications 100 Metcalfe Street Ottawa, Ontario	(613) 992-6763
W. H. Parker VE5CU Ass't Coordinator Saskatoon Emergency Measures Organization 1008 10th Street East Saskatoon Saskatchewan	(306) 652-8411
H. S. Poole VE3VP 322 Frank Street, Apt. 205 Ottawa, Ontario	(613) 234-1613
K. Rolison VE3CRL Power Engineer C.N. Telecommunications 151 Front Street Toronto, Ontario	(416) 365-3853
J. B. Streater (licensed-no call) Communications Officer Ontario Emergency Measures Organization 1424 Islington Avenue Islington, Ontario	(416) 965-4385

TOPICS FOR DISCUSSION

1. The establishment of machinery for liaison between a "national crisis centre" and the Canadian Amateur Radio Federation Inc. executive with the objective of giving amateurs engaged in emergency traffic a focal point for traffic to and from government agencies on the national level (such as the Managua earthquake).
- Ron Belleville, VE3AUM
2. Development of similar procedures for liaison between:
 - (a) provincial societies, provincial emergency organizations and their communications officers and,
 - (b) the same for the liaison between municipal level emergency organizations and local clubs.- Mike Considine; Pierre Massicotte, VE2DEV; Bill Parker, VE5CU.
3. Explore the possibility of designating exclusive emergency frequencies in the amateur bands, either pre-assigned or to apply to an amateur frequency being used for emergency traffic.
- Steve Chisholm, VE4AI
4. The use of amateur VHF and UHF repeaters in wartime. (Refer to EMO Bulletin No. 7, paras 8 - 11). Discussion of the feasibility of such use and any changes necessary to Bulletin No. 7, other than to Schedule A, frequency allotments.
- 'Jap' Streater
5. Recommendations for changes to Schedule A of EMO Bulletin No. 7 (re-assignment of amateur frequencies in wartime) to accommodate the use of amateur VHF repeaters, including the use of 30 Khz spacing in channel allotments.
- Sonny Gray, VE3BTS
6. Review of the DOC guidelines for the operation of amateur repeaters as they would apply to repeater use in peacetime emergencies.
- Art Blick, VE3AHU
7. The problem of power line and other interference to the amateur service. The necessity for a consistent DOC policy on a national basis regarding the handling of complaints on interference to the amateur service.
- Ken Rolison, VE3CRL
8. The use of GRS equipment and frequencies by emergency organizations.
9. The relaxation of the standards for the use of GRS equipment on emergency frequencies (see Canada EMO Bulletin No. 8) 27.80MHz, from specification RSS 120 to RSS 136
- Paul Amyot

10. The use of amateur (non-type-approved) equipment on EMO frequencies in both wartime and peacetime emergencies.
- Bill Parker, VE5CU
11. Emergency power sources.
- Ken Rolison, Ve3CRL
12. Open forum: Panel - Paul Amyot, Canada EMO
Bill Lanyon, DOC
W. J. McCurdy, DOC
A. E. Blick, VE3AHU

RECOMMENDATIONS AND CONCLUSIONS

ACTION BY

The various factors to be considered in evaluating the role of the Amateur Experimental Service in emergency communications and the form which that role could take were discussed in detail under the topic headings outlined in page(x) and the following recommendations and conclusions were arrived at:

1. IT IS RECOMMENDED THAT:

- agree
- (a) The Canada Emergency Measures Organization discuss with federal agencies such as the Departments of National Defence and External Affairs or with any federal crisis management centre which may be established, the matter of determining and making known a continually-manned point of contact to which Amateur radio operators engaged in emergency communications related to a national or international disaster could deliver official emergency traffic, and from which they could accept such traffic. Canada EMO
- (b) The Canadian Amateur Radio Federation Inc. make known to the Canada Emergency Measures Organization the Amateur organizations or individuals which the federal agency or agencies in 1(a) should contact if the agency or agencies wish to make use of the Amateur Experimental Service for passing emergency traffic. Canadian Amateur Radio Federation

2. IT IS RECOMMENDED THAT:

- agree
- (a) At the provincial level, liaison concerning emergency communications planning between government and the Amateur Experimental Service should be carried out between the communications officers of the provincial emergency organizations and the provincial Amateur Radio society. Provincial Emergency Agencies and Provincial Amateur Radio Societies
- agree
- (b) The point of contact between provincial government and any provincial Amateur organization or individual Amateur engaged in emergency communications should be the provincial emergency organization which has a 24 hour, daily response capability for emergency traffic addressed to or from its provincial government. Regional Directors of Canada EMO should be informed of these liaison arrangements. Provincial Amateur Radio Organization
- (c) The liaison between local government and Amateur Experimental Service licensees should be as for 2(a) and (b) above, with the municipal, county or similar emergency organizations acting as the point of contact for local Amateur radio clubs and repeater owners where they exist; or in their absence, for individual local Amateurs committed to emergency communications work and local net control station operators. Local Amateur Radio Clubs or Individuals

3. IT IS RECOMMENDED THAT:

The telephone numbers and addresses of provincial and local emergency organization duty officers and emergency operating centres be made known to individual Amateurs through the bulletins published by provincial societies and local clubs and through "The Canadian Amateur".

Canadian Amateur
Radio Federation
Inc.
Provincial Amateur
Radio Organizations

4. IT IS RECOMMENDED THAT:

The provincial societies and local clubs, respectively, or in the absence of the latter, interested and active individual Amateurs provide the provincial and local emergency coordinators or directors with a list of Amateur licensees available for emergency work, including their addresses and telephone numbers, their capability, including repeaters and their coverage; and properly maintain these lists.

Local Amateur
Radio Clubs

5. IT IS RECOMMENDED THAT:

As a principle, where there is not already utilization of the Amateurs by the provincial emergency agencies that they not direct the Amateurs how to organize themselves in support of emergency organizations but instead approach the appropriate Amateur organization, on the provincial or local level, making known their communications requirements and asking its assistance and suggesting that the Amateurs organize themselves, using active, emergency-oriented Amateur operators to meet the requirements of the emergency agencies. These communications requirements should include the Amateur tie-in with municipal emergency agencies.

Provincial
Emergency
Agencies

6. IT IS RECOMMENDED THAT:

(a) Amateur auto repeater facilities be considered for inclusion in emergency measures communications planning.

Provincial Emergen-
cy Communications
Planners

(b) The provincial Amateur Radio societies provide all detailed information on repeaters in their provinces to the provincial emergency co-ordinators.

Provincial Radio
Societies

(c) In view of the potential importance of the Amateur repeater facilities as a back-up system in an emergency, the frequencies in the 144-148 MHz band allocated for emergency agency use in wartime (as shown in schedule "A" to Canada EMO Bulletin No. 7), be reviewed and changed in order to accommodate the use of Amateur repeaters now in use or likely to be established.

Canada EMO

(d) This revision of Bulletin No. 7, Schedule "A" provide for the inclusion of the 220-225 MHz and 420-450 MHz bands in these allocations for Canadian wartime use.

Canada EMO

Concur

What are
the dimensions
of this problem?

- (e) If revisions to Schedule "A" continue the use of spot frequencies these should be revised to reflect 30 KHz rather than 60 KHz channel separation in order to provide for any further narrowing of channels and should be compatible with repeater frequencies now in use, or likely to be used. Canada EMO

(No mention was made of the allocation in the six metre band. This band is also used for repeater operations and it is suggested that it be included in the review of Schedule "A". (Editor)).

7. IT IS RECOMMENDED THAT:

what problems would this entail?

The standards for the use of GRS equipment for use on the emergency agency frequencies 27.80 MHz be relaxed from RSS 120 to RSS 136 for mobile stations and RSS 140 for base stations. Canada EMO

8. IT IS RECOMMENDED THAT:

Third party traffic rules for Amateur Experimental Service be clarified by DOC. Canadian Amateur Radio Federation

9. IT IS RECOMMENDED THAT:

agree

In order to promote and maintain the interest of Amateur radio operators in emergency agency communications, provincial and local co-ordinators should be asked to speak to key radio club meetings and provincial radio society conventions in order to acquaint amateur operators with the communications requirements for emergency operations. Provincial Societies and Local Clubs

10. IT IS RECOMMENDED THAT:

good idea

Operators in the Amateurs Experimental Services who use their facilities to assist emergency agencies should be encouraged to use and supplied with a message format similar to that of the emergency measures organizations and that it be distinctly labelled as an "Amateur Radio Message Form". (See Annex 31)

CONCLUSIONS

good

1. After thorough discussion of a number of draft recommendations, it was concluded that the designation of exclusive emergency frequencies in the Amateur bands was not practical and that to date the "self-policing" of frequencies being used for emergency communications and the existence of the regulation against "wilful interference"* both here and in the United States, adequately protects emergency operations.
2. After discussion on the Radio Regulations and the repeater guidelines as they affect the case of Amateur repeaters being used in peacetime emergency communications, it was concluded that neither the present Radio Regulations nor the present guidelines for repeater operations present any impediment to such operations and hence no changes are necessary.

good

*The Radio Act, R.S., c.233, s.1, Chapter R-1, Section 9(1) and FCC Rules and Regulations, Vol. VI, Ch. 97, Section 125.

3. In cases of electrical power line interference to Amateur Experimental Stations, the Amateur should obtain as much fully-documented technical evidence as possible and present it to the DOC and the electric power company.
4. DOC will not permit the use of non-type-approved Amateur equipment on EMO frequencies and it is not practical for manufacturers or users to seek type approval on Amateur equipment.
5. Surplus equipment from other services made available to emergency authorities can be put into service on emergency frequencies if it meets with the technical requirements of the DOC. Surplus equipment can be transferred from its original use to EMO use on 148.65 MHz if it meets RSS 126. Older equipment approved under RSS 106, 107, 108 and 109 is no longer acceptable for 148.65 MHz operation when removed from original service. Emergency authorities are advised to contact the DOC Field Office in the event that they have the opportunity of obtaining surplus equipment.

What are the implications of this?

THE ROLE OF THE AMATEUR EXPERIMENTAL RADIO SERVICE
IN EMERGENCY COMMUNICATIONS

SUMMARY OF THE DISCUSSIONS

The method of discussing the problems posed by the various items was to have a short presentation on each one of them, by one of the participants who was familiar with the subject. After the presentations the meeting broke up into separate groups, each charged with considering the various factors involved and each bringing back to a central discussion group a separate recommendation which was then subject to further review and discussion by the whole group.

Item 1

"The establishment of the necessary machinery for liaison between a national crisis management centre or some federal authority and the Canadian Amateur Radio Federations Inc. executive with the objective of giving Amateurs engaged in international or national emergency communications, such as in the Managua earthquake, a focal point for delivering and accepting emergency traffic for the federal government." (See Recommendation No. 1)

The discussion was introduced by Ron Belleville VE3AUM who, as a result of his experience in the Managua disaster, proposed that whatever federal agency could assure delivery of incoming emergency traffic should have its name and telephone numbers made known to Amateur operators.

In the handling of international disaster traffic, it could be the Department of External Affairs, while in national, domestic disasters, it would be Canada EMO or, if one is set up, a national crisis management centre.

Other questions which arose and which should be answered in the course of the work involved if Recommendation No. 1 is carried out by Canada EMO are:

- (a) What methods are to be used to disseminate such information to Canadian Amateurs?
- (b) To what extent should the information be disseminated? Should it be available to all Amateurs or just to executives of Amateur Radio organizations?
- (c) Would the cognizant government agency be willing to recognize the individual Amateur as a point of contact or just the organizations?
- (d) Would not provincial emergency agencies be able to provide the link with the cognizant federal agency?

- (e) In the event of an international disaster or a domestic emergency in which the Amateur Service is involved in either a primary or a supplementary communications role would it be possible to have Amateur equipment installed in the quarters of the federal agency functioning as a crisis centre or those Departments heavily involved? This equipment could be transmitters and receivers, monitoring receivers only, or a direct temporary line link or phone patch to an amateur station.

Item 2

"Development of similar measures (as in Item 1) for liaison between Amateurs and;

- (a) provincial societies, provincial emergency agencies and their communications officers;
- (b) the same for municipal level emergency agencies".
(See Recommendations Nos. 2(a), (b) and (c)).

- 2(a) The British Columbia Civil Defence (C.D.) communications system was outlined by Mike Considine as a start to the discussion. The method of Amateur liaison in B.C. is simple. The Amateur portion of the emergency communications is divided into six nets whose net controllers have contact with the Zone C.D. co-ordinators. There is a "rear link" from Zones to C.D. headquarters at Victoria, where there is a 24-hour duty officer on a paging system.

He strongly urged that the present rules concerning the Amateur Service in wartime should be reviewed and amended to permit use of authorized, previously designated Amateur stations in wartime.

(The procedures for "shut-down" applying to Amateur radio stations in wartime are in the emergency legislation which can be activated if the War Measures Act is invoked. "Re-activation" is outlined in EMO Bulletin No. 7 and Ch. XXII of the Guide to Civil Emergency Planning.- see Annexes 7 and 9). Editor)

In Quebec, according to Pierre Massicotte, VE2DEV, the provincial emergency organization Protection Civile, (Civil Defence) does not rely on nor incorporate Amateur stations in their communications system. The formal emergency communications system has served the province well. It appears that Amateurs could be utilized but a lack of co-ordination of Amateur efforts to date, due to divided opinion as to the organization or persons to represent amateur radio to Protection Civile has resulted in little effective liaison.

2(b) On the municipal level the contact for emergency traffic for local government between Amateurs and the local government should be through the local emergency organization, according to Bill Parker, VE5CU. On the whole, he said, Amateurs are ill-informed as to how to react to an emergency in an organized fashion. He pointed out that Saskatchewan has integrated the Amateur Service into its emergency system and that those in the system are trained and regularly exercised. Saskatchewan has held top honours in the Amateur Radio Emergency Corps competitions (sponsored by the American Radio Relay League) but even after 37 years of existence there is little ARRL AREC activity in the rest of the country, he said.

The core of emergency communications is commercial or utility communications but in a disaster these may quickly become overloaded, with even a ten-fold rise in traffic. It is necessary therefore to have a back-up system. For example, hospital line communications would quickly become jammed and they therefore require a back-up communication system.

In Saskatchewan EMO uses a provincial network of Amateur equipment and operation on 3780 KHz. Emergency agencies also operate on 27.80 for emergency work utilizing Amateur and GRS personnel trained as EMO operators. In Saskatoon the hospitals also use VHF links between three hospitals and mobile units, utilizing Amateurs integrated into the EMO system.

There is complete interlocking of all communications systems. All EMO owned emergency systems are manned by EMO personnel recruited from both the Amateur Service and the General Radio Service (GRS).

Contact between Amateurs and the Saskatoon municipal government is through the communications chief of the Saskatoon Emergency Measures Organization, who directs all public utility, Amateur and GRS participation. (See Annexes 17 and 18)

Item 3

"Explore the possibility of designating exclusive emergency frequencies in the Amateur Service bands either pre-assigned or to cover a frequency being used for emergency traffic and the methods of designation."
(See Conclusion No. 1)

This item generated a great deal of discussion and several attempts were made to come up with a suitable concept and procedure for designating emergency frequencies for Amateur operation but so many questions were raised which appeared to be obstacles to a simple and easy solution that it was concluded that present practices have worked out satisfactorily and that no changes or revisions to the Radio Regulations are necessary or desirable.

Steve Chisholm, VE4AI, led the discussion, noting that such arrangements were possible in the United States under the FCC rules and regulations (see Annex 24) but many questions arose in his mind as to the factors involved:

WHAT IS THE COMMUNICATIONS REQUIREMENT?

The likely requirements must be decided in advance.

- HOW is it made public?
WHO does planning for designated frequencies? Interested Amateur organizations?
HOW is the Amateur notified in advance of such designation?
HOW is the Amateur alerted in event of a declared emergency?
WHO decides if there is an "emergency" or declares one?

All of these questions would involve a great deal of co-ordination between Amateur organizations, DND, DOC; and probably regulation changes.

A number of recommendations were drafted but after considerable discussion and having regard to the facts that:

- (a) the Amateurs have a good record of self-policing;
- (b) DOC would like to have it remain so, with as little regulation as necessary;
- (c) the existence of the "wilful interference" regulation both here and in the U.S.A., and;
- (d) most provincial societies or regular nets use frequencies which are well-known to Amateurs, and
- (e) the unanimous view of the Amateurs present that "the less regulation, the better."

It was concluded that there was no need for official peacetime designation of Amateur frequencies as being exclusively dedicated to emergency communications.

Item 4

"The use of Amateur VHF and UHF repeaters in wartime. (See Annex No. 9, EMO Bulletin No. 7, paras 8, 9, 10 and 11.) (See Recommendation No. 6)

Jasper Streater, in introducing this subject, noted that the emergency use of Amateur repeater facilities, which were practically non-existent ten years ago, was not provided for in the present wartime allocation of Amateur frequencies to other uses and that it was mentioned of this particular situation at the Canada EMO Emergency Communications Planning Officers' Conference in February, which instigated the present Working Group. He reiterated that local emergency agency co-ordinators in Ontario would like to include the use of local Amateur operators in their emergency communications

plans but the present wartime frequency assignments do not permit them to do so. If use is to be made of this extremely valuable communication resource, then changes will have to be made to these assignments. (See Annex No. 9, Canada EMO Bulletin No. 7, Schedule 'A')

While there are some "spot frequency" allocations on 6 and 2 meters, there are none on 220 MHz or in the 450 MHz bands for Canada, although they do exist in the U.S. (See the RACES booklet; Annex 12.)

In B.C., Mike Considine said, emergency EMO tactical call signs have been assigned to certain mobile and fixed stations on repeaters. The Amateur operators have Restricted Radio Telephone Operators Certificates.

It was suggested that provincial radio societies might provide lists of repeaters to provincial co-ordinators and keep them up to date. Repeater councils in various areas, including joint Canadian/U.S. councils in border areas, are a source of such information.

Although in commercial use repeaters are regarded as "frequency wasters" by DOC, the Amateur repeaters provide a tremendous flexibility and survival factor not found in commercial repeaters. In any event there is still a large amount of unused VHF and UHF Amateur frequency spectrum available in Canada for repeaters.

Item 5

"Discussion and recommendation for revision of wartime Amateur VHF and UHF frequency allocation to permit use of repeaters, including channels to be added and consideration of split channel (30 KHz spacing) in allocations." (See Recommendation No. 6 and discussion on Item 4 which was broadened to include this.)

Item 6

"A preview of the repeater guidelines and the regulations applicable to Amateur radio participation in peacetime emergency communications and the effect of both of these on the use of Amateur repeaters in peacetime emergency communications." (See Conclusion No. 2 and Annex 2)

A number of points were brought up on both the introduction by Art Blick VE3AHU, and in the subsequent discussion.

Tracing the history of the "repeater guidelines" he stated that as it now stands, there is no regulation prohibiting the operation of repeaters but there is no authorization to use them either. The guidelines were drafted by Amateurs for the DOC and in October 1972, the DOC asked the Canadian Amateur Radio Federation Inc. to contact the provincial societies as to the suitability of the "guidelines". For the protection of the Amateur and to permit uniform rulings by the DOC field personnel, the DOC wished to put them in the form of regulations.

The response to the Federation canvass was pretty well unanimous in declaring that the guidelines are suitable as they are. Some minor wording changes were recommended by two or three clubs, changing negative statements to the more flexible, positive approach. The regulations pertaining to the Amateur Service in peacetime emergencies (Radio Regulations PtII, Sec. 5(5)) mentions "recognized relief agencies" and this includes the official emergency agency at the federal, provincial or local level, but Amateur stations engaged in emergency communications must adhere to those regulations governing emergency traffic. (See Annex 8.)

Individual Amateurs engaging in emergency communications must notify DOC of such activities, but for those Amateurs who do so on behalf of, or as part of, an approved civil emergency communications plan, the official emergency agency involved should notify DOC of the Amateurs' participation. This includes repeater operations.

In the interest of highway safety, The Canadian Amateur Radio Federation Inc., has asked DOC to waive the necessity for logging by mobile stations. The original rules applied to logging never envisaged the mobile set nor the extent of its use today.

The rule is anachronistic and may well be relaxed. Logging for base stations is however, protection against unfounded charges of interference.

Unco-ordinated use of repeater channels is causing some problems and could cause more, but the formation of repeater councils on a regional, and in some cases on a local across-the-border basis has solved many of the problems. Repeater advisory committees on the national, provincial and local levels would be an even better approach.* Most frequency plans now utilize 30 KHz channel spacing for $\pm 7\frac{1}{2}$ KHz deviation (narrow band FM) and 60KHz for ± 15 KHz deviation (wide band FM). A national repeater frequency plan is being formulated by interested parties and if followed, could work with 4 sets of crystals which would ensure coast-to-coast coverage without overlapping of repeater coverage areas.

Item 7

"The problem of power line interference to the Amateur service. The necessity for a consistent DOC policy on a national basis, regarding the handling of amateur complaints." (See Conclusion No. 3 and Annex 26.)

After Ken Rolison's (VE3CRL) talk on this topic, there was an interesting discussion on the "anti-galloping" device which recently appeared on high tension transmission lines in the Ottawa area. This apparently produced a corona-like interference across a wide spectrum including the Amateur bands, and DOC, Ontario Hydro and local amateurs co-operated to pin point both the source of the interference and to remove it.

*The Amateur Radio League of Alberta, for example, has an advisory committee on repeater activities and provides equipment, technical and financial assistance to repeater groups which follow the committee's guidelines for operation.

About half of the time which DOC spends on interference tracing is spent on checking power line interference. It would appear that with more liaison between DOC and power companies, and some training courses, power companies could do much to correct such problems themselves.

While power line interference (mainly corona) will probably rise as demands and voltages are raised, possibly new developments may help to eliminate the problem.

Unfortunately, the main problem, that of corona, increases or appears with bad weather and many emergencies are generated by weather conditions so that when most needed, radio communication may encounter such interference.

Amateurs are advised to collect as much evidence as possible and present it to DOC and the power companies if they encounter this interference.

Item 8

"The Use of GRS Equipment and Frequencies." (See Annex 8)

This discussion was introduced by Bill Parker, VE5CU, who noted that a 1968 agreement between Canada EMO and DOT authorizes the use of 27.80 MHz by civil emergency organizations as a frequency for their emergency operations. Equipment must be type-approved GRS equipment and operated under an emergency agency call and license, not on a GRS call or permit. In utilizing GRS operators and their equipment, the emergency agency must ensure, before the equipment is used on 27.80 MHz or crystals for this frequency are issued to the GRS operator, that the GRS equipment is type-approved. An advantage of this frequency is that it is free from DX interference because it is not assigned to the Citizens' Radio (CB) Service in the United States. The Saskatoon Emergency Measure Organization supplies crystals for this frequency for GRS equipment manned by GRS volunteers. This frequency is monitored and taped by the Regina police to ensure that no misuse occurs and in order to have immediate notice of emergencies. All transmissions are recorded which assists in the detection of any violations.

Art Blick said that the Kingston Fire Department is using GRS equipment but is plagued by interference. He asked if they could use 27.80 MHz. The answer from Bill Lanyon of DOC, was yes, that such services could use it under certain conditions and only with type-approved equipment. That frequency has been made available for emergency measures agencies use and could only be used by fire departments in emergency situations involving the emergency agencies. Any request for such use must be directed to the local DOC Field Office.

Item 9

"The relaxation of standards for the use of GRS equipment in the emergency frequency 27.80 MHz from specifications RSS 20 to RSS 140 for the base stations." (See Recommendation No. 7, Conclusion No. 5 and Annex 8)

One problem, according to Jasper Streater is that while much of the GRS mobile equipment can meet the specifications, there are few base stations which can.

Before buying or using GRS equipment emergency organizations can check for type approval by consulting the "Radio Equipment List, 1973 (which is available from Information Canada) and with the DOC Regional Office. If emergency planners wish to use a certain GRS equipment on 27.80MHz, they should consult with their local DOC Field Office as to its acceptability.

The question was also raised by Bill Parker as to whether or not type-approved equipment released from a different service as surplus could be used on EMO frequencies. DOC representative Bill Lanyon said that if the equipment was "listed" it could be transferred from one use to another, for example from fixed land station telephone service to land fixed station EMO service but not to marine service.

DOC's Bill Lanyon asked why Canada EMO specifies RSS 120 equipment to be operated on 27.80 MHz. The reply from Paul Amyot was that emergencies require reliable and adequate equipment and that RSS 120 was therefore specified instead of RSS 136 because it was deemed that the latter specification is too permissive.

Mike Considine reported that 27.255 MHz and 27.660 MHz are reserved for municipalities but RSS 120 equipment must be used.

As it is, many municipalities have equipment which does not meet the newer RSS 120. Where, however, this equipment meets RSS 136 and RSS 140 and if the equipment was purchased before RSS 120 was issued it can continue to be used. Mike Considine said that he found equipment which meets RSS 136 of "pretty good quality so why resort to a higher quality specification. "Why not use RSS 136 for municipal equipment?" he asked.

Bill Lanyon replied that as far as DOC is concerned, the equipment referred to must at least meet RSS 136 and be listed. As for determining whether a specific equipment in use by emergency organizations or municipalities meets RSS 136, if sufficient information is provided by the owners to DOC to identify it and show its performance and if this meets RSS 136, it will be listed.

Bill Parker said that his organization was limited in its choice and use of equipment by base stations having to conform to RSS 120.

(The above remarks apply to equipment now in use. New equipment for the purposes discussed above, in order to qualify for licensing in the band 27.28-50.00 MHz must meet current Radio Standards Specifications RSS 120 (mobile AM/FM up to 3 watts) or RSS 140 (land/mobile AM).)

Item 10

"The use of Amateur (non-type approved) equipment on EMO frequencies in peacetime and wartime." (See Conclusion No. 4)

As noted under Item 9 Bill Parker said that type-approved equipment for EMO use on VHF frequencies such as 148.65 MHz is too expensive for their budget and he wanted to use type-approved surplus equipment rather than be concerned about using Amateur equipment on this frequency.

Mike Considine, taking another view, asked if Amateur equipment could be used on 148.65 MHz for emergency communications. According to DOC's Bill Lanyon, in peacetime, Amateur equipment could only be used on EMO frequencies if it is type-approved but it is not feasible to obtain type-approval on Amateur equipment as it serves no purpose insofar as the manufacturers are concerned and adds a cost factor which they would not consider worth the effort.

As to the wartime use by emergency agencies of Amateur equipment and facilities on the Amateur frequencies re-allocated to EMO, there is no regulation or requirement governing the equipment used.

Item 11

"Emergency power sources for Amateur equipment"(See Annex 25).

Item 12

"The use of Amateur radio in recent emergencies."

- (a) Pierre Massicotte, VE2DEV, described the functioning of the emergency networks used by Quebec's Protection Civile during the spring flooding of the St. Lawrence in the Montreal area. Amateur radio does not form a part of these networks.

Through the use of aircraft and car mobile radio units reporting on ice conditions and precipitation, reports were sent to Quebec City and the authorities there were able to evaluate and consolidate this information and feed back warnings to the agencies and municipalities which were threatened.

The idea of teletype was considered but proved to be too costly and the radio nets, including the metropolitan Montreal system of repeaters, tied in some 65 municipalities. Information fed from the field unit to Quebec was in the hands of the affected municipalities within hours. This information system permitted them to alert and evacuate people from the flooded areas.

- (b) New Brunswick Flood Reports (see Annexes 19 and 20).

A Typical Repeater System

A description of a typical Amateur VHF repeater facility was given by C.A. (Sonny) Gray when he described repeater VE2CRA which serves the Ottawa-Hull area. The repeater is sponsored and financed by the Ottawa Amateur Radio Club. The site is on commercial property in the Gatineau Hills to the north of Ottawa, which high location gives an excellent coverage of 60-70 miles in radius. It is being converted to all solid state equipment (12 volts DC) operated by float-charged batteries. The 110 volt emergency supply is provided by the commercial diesel auxiliary power unit. The antenna is a vertical dipole fed with 11 watts. The repeater consists of a 2 metre repeater and a separate one on 450 MHz at the same site. The two can be tied together in various ways. Plans are in progress for a 450 MHz link with Montreal and other repeaters.

The number of local users is between 175 and 200. There are probably an additional 500 units, located in the Montreal--Ottawa --- Kingston area, which are capable of using this repeater.

The Club is now developing a portable repeater for emergency replacement of the main facility. It can be mounted on a building or in a car, using separate receiver and transmitter antennas separated by about 100 feet.

The Ottawa-Carleton Regional EMO Communications System

The Ottawa-Carleton Region Emergency Measure Organization networks were described by Fred Holcombe, the Regional EMO Co-ordinator.

Using a VHF repeater, Regional coverage is complete and ties in the municipalities and all police forces on the same net. The system is available 24 hours a day and utilizes base stations, hand portables and mobile units on EMO VHF frequencies.

The GRS personnel are used in the system with some success. All hold RRO certificates and can man the EMO equipment. A GRS base station is set up at EMO HQ to tie in with the EMO nets.

A direct line goes from EMO HQ to all hospitals.

A communications van is being built to include power supplies and operating positions for EMO, GRS and Amateur radio equipment.

OPEN FORUM

The meeting concluded with an open discussion. The panel consisted of Paul Amyot, for Canada EMO, W.T. Lanyon and W.J. McCurdy for DOC and Art Blick for the Canadian Amateur Radio Federation Inc.

Questions discussed were:

Q. Mike Considine:

When is the new edition of the RRO manual to be available?

A. Bill Lanyon:

It is now available from Information Canada for 75 cents.

Q. Mike Considine:

Because broadcast stations are including emergency communications should they not be required to have auxiliary power units (APU's)?

A. Paul Amyot:

Canada EMO is drafting a letter to the CRTC suggesting inclusion of APU's in broadcast stations.

Art Blick:

The Canadian Amateur Radio Federation would like to propose a national VHF repeater frequency plan on main travel routes. Sonny Gray has been working on a proposed national repeater frequency plan.

Sonny Gray:

If the following frequency plan for 2 metre repeaters was followed across Canada we could work repeaters when travelling from coast-to-coast using only 2 receive crystals and 2 transmit crystals. These are:

Repeater Frequencies (MHz)

<u>In</u>	<u>Out</u>
146.46	147.06
146.34	146.94

for primary repeaters in each area and by utilizing the following frequencies "secondary" repeaters could be added to supplement the primary coverage and to accommodate more groups of users

146.52	146.88
146.58	147.18
146.22	146.82
146.52	147.12

In some cases these channels are compatible with repeaters in the United States.

The national frequency plan has a 200-mile separation between repeaters using the same frequency. A mobile using two transmit and two receive crystals could work a repeater in each area from coast-to-coast as it was passing through. It would be feasible then to operate additional repeaters with the secondary set of crystals. (See Annex 5A)

By linking repeaters on 450 MHz in an emergency you could have a comprehensive coverage of disasters involving more than one area or province.

There are only three or four gaps in repeater coverage in Central and Eastern Canada. Coverage extends as far west and north as Sudbury and Sault Ste. Marie. In the Prairie Provinces there are gaps between Winnipeg, Brandon, Regina, Saskatoon, Calgary. In B.C. there is a unique problem due to the mountains.

Q. Mike Considine:

What use will be made of 144-148 MHz in wartime? Can EMO equipment use this band? Can Armed Forces equipment use it? What regulations cover the cessation of Amateur operations in wartime? What regulations cover appropriation of Amateur facilities by emergency authorities in wartime?

In the discussion which followed it was brought out that for EMO equipment to use these frequencies would require additional crystals and re-tuning which could necessitate modifications to EMO equipment. It would entail time, labour and expense which would probably could not be spared and would not be worth the effort in view of the availability of Amateur equipment and facilities.

Obviously, as recommended, Canada EMO Bulletin No. 7 and Schedule A will have to be revised if utilization of Amateur repeaters or simplex facilities is to be made in wartime.

Subsequent inquiry and research by the Editor turned up the answers to these questions:

- (a) Only the few military VHF equipments utilizing synthesizers could utilize the Amateur 2 metre band within a practical time frame.
- (b) The emergency legislation which would become effective in wartime would permit the closing down of Amateur stations.
- (c) For an answer as to what regulation covers the appropriation of Amateur equipment in an emergency, see Annex 8 which contains extracts from the Radio Act and the Radio Regulations.

Q. Ken Rolison:

Because of the usefulness of the Amateur Service in an emergency it is distressing to find that amateur operations are not adequately protected by the Radio Regulations and in some cases suffer by administration of the Regulations in the field.

A "clean" transmitter which meets the regulations can be put off the air or restricted because of front-end overload or rectification in receiving equipment and even in "home entertainment" equipment. What can DOC do to alleviate this threat to Amateur operations, when the real problem in most cases lies with inadequate design of home receiving and entertainment equipment?

A. Bill Lanyon:

Amateurs can assist in settling interference problems by means of their organized interference committees. It does work.

Q. Ken Rolison:

In some cases, the Amateur having assisted and co-operated to the fullest extent with the DOC inspector, the latter has informed owners that the problem was the owner's responsibility but this has not occurred in all cases. Why could there not be an official and consistent policy applied by DOC here?

Bill Lanyon:

The chances that DOC would formally put into regulations such a policy is unlikely.* There is to my knowledge no such existing legislation but if we did come up with anything it would probably be developed in conjunction with Canadian Standards Association.** There are economic factors to be considered here as well. It is difficult to sell more expensive equipment in Canada. The situation is probably comparable to that in the auto industry in its problem to incorporate adequate anti-pollution controls in these products.

Doug Burrill:

Is there a channel within DOC which is available to the Amateur for appeal of a decision made by an inspector in the field?

Bill Lanyon:

Decentralization of the DOC activities means that the Regional Office Directors have a great deal of control. They report to an Assistant Deputy Minister, Regional Offices, and hence do not, in many cases, have a direct responsibility to operational branches in headquarters. However, an Amateur is quite free to take whatever action he wishes.

Doug Burrill:

Is there any regulation which protects non-radio devices such as "hi-fi" sets and other similar non-radio home entertainment devices.

Bill Lanyon:

In cases of such "interference" the best approach is common sense and co-operation of all parties.

Sonny Gray:

What protection is there for the Amateurs against interference to his reception?

Bill Parker:

There is a case in Saskatoon. DOC ordered a sign removed which was generating radio interference but the order was not complied with and the case is slated for the courts, which will take at least two years.

*See Annex 30 for legislative proposals in the U.S. Congress.

**Editor's Note:

The Canadian Radio and Television Planning Board has been asked by DOC to investigate this problem.

A CANADIAN AMATEUR RADIO EMERGENCY SERVICE

Subsequent to the meeting and as a result of discussions with various people who attended, it became clear that while in some areas voluntary well-organized Amateur groups interested in emergency communications provide admirable assistance to emergency authorities, this was not so all across the country, hence the idea of forming an officially recognized nation emergency communication service utilizing amateur stations was evolved. Bill Parker, assisted by Mike Considine and Frank Ryder (who wrote Annex 1) is preparing a concept paper for further study as to the feasibility of the idea.

Government interest in Amateur radio as a source of assistance in emergency communications has been evidenced by the presentations included in the Emergency Communications Planning Officers' Conference in February, the Working Group on which this Report is based and an official study to be undertaken of the plan noted above.

Addressees on the distribution list of this Report will be advised of progress of the forthcoming study and their co-operation is solicited in responding to enquiries for relevant information.

July 1973

ANNEXES - PART I

AMATEUR RADIO SERVICE REPEATERS

Annex

- 1 - Brief on Emergency Communications and the Amateur Experimental Service in New Brunswick as presented to the Cabinet of the Province of New Brunswick
 - F. H. Ryder, B. Sc., M. Eng.,
(M)IEE, C. Eng. FIEE (VEIAIL)
N. B. Power Commission
- 2 - The Use of Amateur Repeaters in Peacetime Emergencies
 - A. E. Blick, Pres. Canadian Amateur Radio Federation, Inc.
Comm. Officer, Frontenac-Kingston Co. EMO
(Staff, Royal Military College, Kingston)
- 3 - List of Repeaters in Canada and Northern United States
 - courtesy ALPHATEXT, Ottawa
(Not current;-only to show extent)
- 4 - Amateur Civil Defense Responsibility
 - extract from "73" Magazine,
April 1973 by W2NSD/1
- 5 - The Florida Repeater Mess is Looking Up"
 - by W4RLG in "73" Magazine for
April 1972 (illustrates why
repeater frequency planning on
a national scale is becoming a
necessity)
- 5A - National Standardization of Repeater Frequencies
 - C.A. (Sonny) Gray, VE3BTS
Ottawa Repeater Group

BRIEF ON EMERGENCY COMMUNICATIONS

and

THE AMATEUR EXPERIMENTAL SERVICE IN NEW BRUNSWICK

as presented to the

CABINET OF THE PROVINCE OF NEW BRUNSWICK

F.H. Ryder
B.Sc. M.Eng., P.Eng.
(M) IEEE. C.Eng., FIEE

Feb. 12, 1973

EMERGENCY COMMUNICATIONS AND
THE AMATEUR EXPERIMENTAL SERVICE
IN NEW BRUNSWICK

The public as well as established emergency organizations and the public utilities have and do rely on the Amateur Experimental service to provide support or supplemental communications in times of emergency when the normal means of communications are damaged, or otherwise inadequate to the task.

In New Brunswick these communications activities have taken place on the so-called HF bands, between 3 and 30 MHz. In recent years, growth in the amateur ranks, and expansion of American privileges into space previously occupied only by Canadian and other amateurs have drastically increased the problem of interference to communications in the HF bands.

Consequently, the provision of reliable local and regional amateur emergency communications must now be based on the use of the VHF bands, those above 144 MHz. In these bands communication is possible only in line of sight, eliminating interference but making more than local communications difficult.

Automatic repeaters installed on hilltops are used to extend the range to 20 to 30 miles, or to a local area.

Radio links joining two or more repeaters can effectively provide reliable regional communications.

It is precisely for that same reason that the regular services, police, fire and the utilities vacated the HF bands between around 2.5 MHz for the VHF band between 30 and 40 MHz and in recent years have moved again to the 152 to 174 MHz band, in between the two amateur bands 144-148 and 220-225 MHz.

Presently there are six automatic repeaters operating on the two meter band, 144-148 MHz in New Brunswick providing local area communications to Moncton, Saint John and Fredericton. These repeaters are not joined by radio links.

It is in support of the concept of providing additional automatic repeaters for other areas of the province, and of providing a network of radio links between repeaters to effect a regional communications network that this brief has been prepared.

F.H. Ryder, P.Eng.
February 12, 1973

1. Introduction to Emergency Communications

Emergency communications as is relevant to the Amateur Experimental service may be divided into two types of service:

- 1.1 LONG DISTANCE: - from around the world to just in excess of the ground wave;-25,000 to 25 miles. Because of the nature of propagation on the bands on which this type of communication is possible, communication is very subject to interference between stations operating simultaneously on the same frequency. This interference is inherent in the very means by which these bands are made so useful for long-distance communication. Stations in many parts of the world use these bands and if using the same frequency at the same time they will interfere with each other. It is therefore not reasonable to use those portions of the spectrum which provide worldwide communications for local communications. Most amateurs respect the frequencies selected for emergency long distance communications, for example, in the recent Nicaraguan disaster. However, for a local emergency effort this freedom from interference cannot be assured.

Interference is also related to band occupancy. Let us examine the 80 meter band. For many years American phone stations were restricted to 3800 KHz and above while Canadian and other phone stations were restricted to 3725 KHz and above. This gave the less populous countries 75 KHz of space, free but for themselves and the American CW operators. In recent years with or without agreement and consent of the Canadian DOC and other national regulatory bodies a class of U.S. amateur "NOVICE" was established and among other things was permitted to use the 80 meter band up to 3750 KC. At times, in parts of Canada, the lower 25 KCs of the Canadian phone band is therefore unusable because of Novice interference.

In late 1972, again with or without agreement and consent of Canadian DOC and other national regulatory bodies certain American phone stations were given permission to operate down to 3775 KC. This means that in Canada today there is only 25 KCs out of a 500 KC band which is relatively free of occupancy by amateurs of other countries. **THUS IT IS ONLY IN THIS 25 KC OF SPACE THAT EMERGENCY COMMUNICATIONS OF A LOCAL OR REGIONAL NATURE COULD TAKE PLACE! IT'S A PRETTY CROWDED PLACE ALREADY!!!**

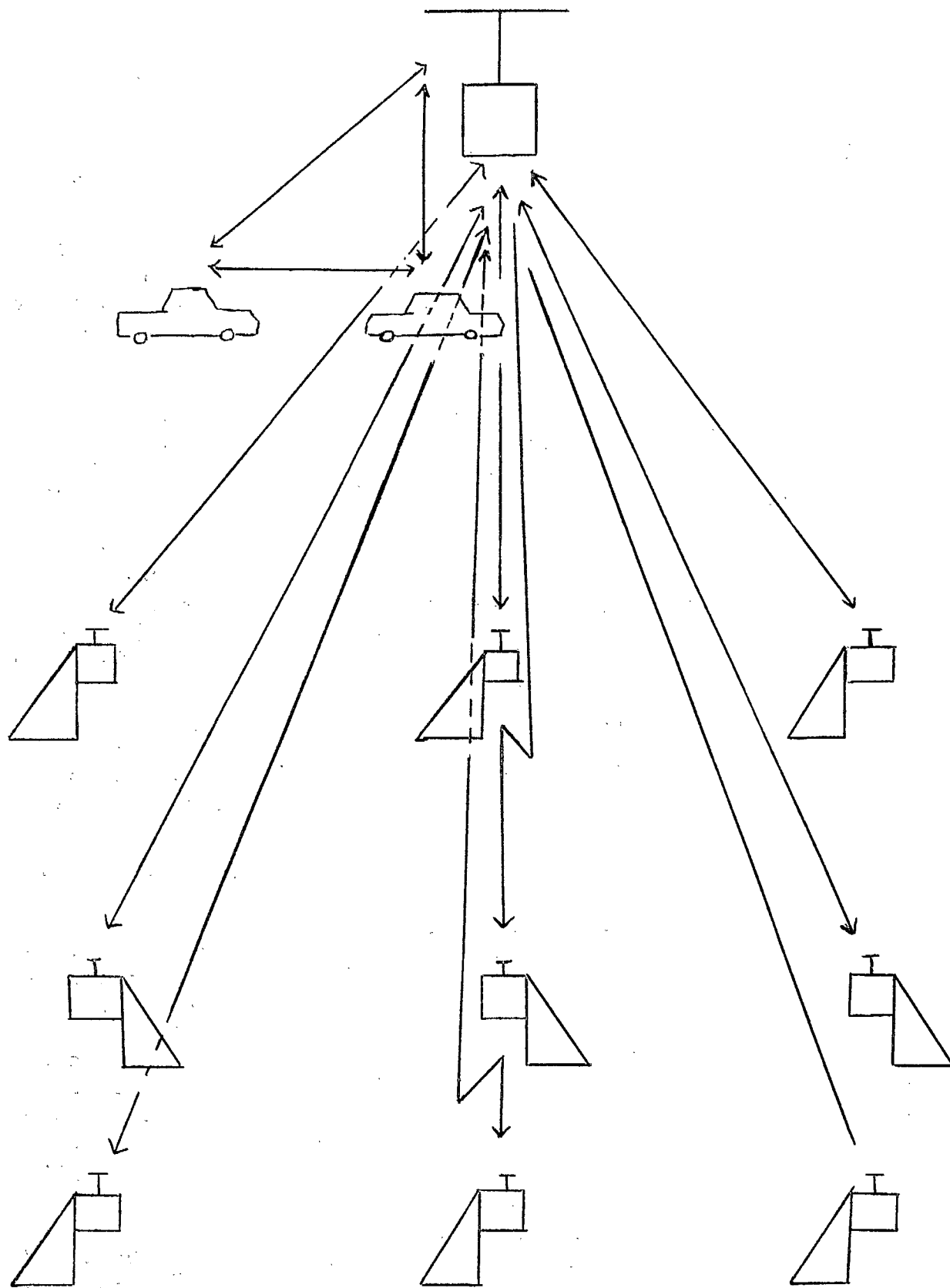

THE HF BANDS ARE DIFFICULT TO
USE FOR DEPENDABLE EMERGENCY
COMMUNICATIONS BECAUSE OF INTER-
FERENCE FROM OTHER PARTS OF THE
WORLD

These developments have tended to emphasize the limitations of all the High Frequency (HF) bands, due to the crowding, and particularly their unsuitability for local and regional communications.

Equipment and antennas for use in the HF applications are generally not too portable but are self-contained and many amateurs are well versed in their deployment.

- 1.2 LOCAL & REGIONAL - A service of increasing importance particularly in times of the more commonly experienced emergencies is furnished by local and regional communications in direct support of or supplemental to the police, or utility, highways, forestry, or as a service to emergency organizations in respect of supplying point-to-point communications, or in patrol, or data gathering functions or dispatch of emergency services to areas needing such services. This type of service is vital in times of storm or flood, forest fire, lost persons, or other forms of emergency.

As indicated in 1, it is not reasonable to use frequencies which provide worldwide or continent-wide coverage to provide communications for local or regional service because of needless interference so caused and encountered.

Many amateurs have equipped themselves with equipment for use in the 2 meter band, 144-148 MHz, very near the 152-174 MHz band used by the police, fire department, highways, forestry and other services. This band provides reliable ground wave coverage ONLY! and as such is not subject to interference from far-off stations. Reliable local coverage, up to 5 miles with highly mobile equipment is possible. This coverage can be extended to 20 to 30 miles through the use of automatic repeaters and amateurs in Moncton, Saint John and Fredericton have through their own resources constructed and operate such stations on a 24 hr. basis. Some stations are equipped with emergency local power supply so as to be immune from power failure. No provisions are made for regional communications by means of radio links of these essentially urban repeaters, nor is any attempt made to provide service to an intervening area should an emergency involving that area occur.

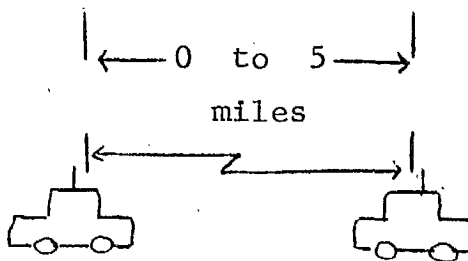

DIRECT COMMUNICATIONS

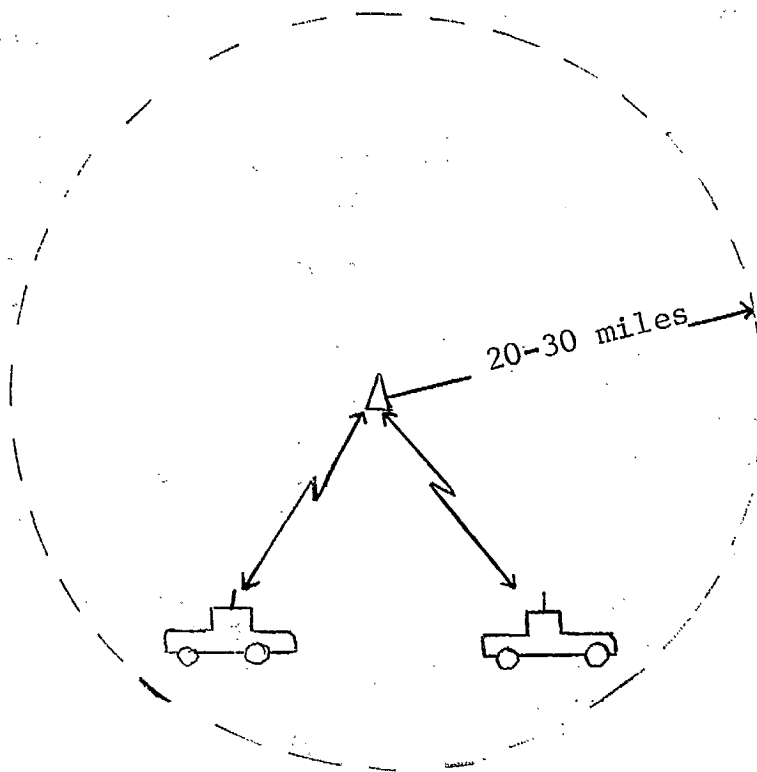

REPEATER-AIDED COMMUNICATION

LOCAL VHF BAND COMMUNICATIONS
WITHOUT AND WITH THE AID OF
AN AUTOMATIC REPEATER

2. Local Emergency Communications in New Brunswick Today

Amateurs have frequency assignments in the 6 meter band (50 MHz); two meter band (144 MHz), 1½ meter band (220 MHz) and 450 MHz band. Automatic repeaters may be used on all of these bands. Six meters is subject to interference with TV Channel 2 in areas where it is used. Used commercial equipment is available for all bands except 1½ meters, with little or no modifications required. Two meters is the most popular band for local service, followed by 450 MHz and lastly by 1½ meters (220 MHz). The unpopularity of 1½ meters is due to the greater effort required to convert commercial gear from 174 MHz to 220 MHz.

In New Brunswick all of the local coverage stations operate in the two meter band. Reliable local coverage, up to 5 miles, with sometimes highly mobile equipment is possible. This coverage can be extended to 20 to 30 miles through the use of automatic repeaters located on hilltops and this has been done in Moncton, Saint John and Fredericton; in each of these areas in the order of 40 amateurs are equipped with both fixed and mobile, as well as a few handheld portable stations. The key to encouraging most amateurs to acquire such equipment is the establishment of automatic repeaters. Where this has been done it has been accomplished at no small cost in equipment, time and effort on the part of the few amateurs who install and maintain the repeater.

As all repeaters presently in service in N.B. utilize surplus commercial equipment employing vacuum tubes, maintenance is a continuing problem of no small consequence.

3. Regional Communications in New Brunswick Today

For those fortunate enough to live on a very high hill in central New Brunswick, it is possible to communicate through any of the repeaters. In this sense there is regional communications, but in the sense of a truly regional communications system, there is none.

4. Local Communications - A Development Plan

It is submitted that amateurs will be encouraged to equip themselves for two meter service through the establishment of automatic repeaters. Without a repeater, in the event of a disaster, even bringing in outside volunteers would

provide only very limited communications coverage. Therefore, in every reasonably sized community there should be an automatic two meter repeater coverage of that local area. In addition, at least two portable self-contained repeaters should be assembled and available for temporary installation and use in isolated areas when required.

5. Regional Communications

Automatic repeaters may be linked by circuits on $1\frac{1}{4}$ meters or higher. It is proposed that each repeater be equipped with $1\frac{1}{4}$ meter repeater receiving on one fixed frequency and transmitting on selectable frequencies, those of the $1\frac{1}{4}$ meter receivers of the adjacent automatic repeaters.

Thus, any amateur through his two meter local area repeater might select connection to the $1\frac{1}{4}$ meter transmitter, then select a $1\frac{1}{4}$ meter receiver in one of the neighbouring repeaters and finally select communication with that two meter repeater. This system avoids the pitfalls of a single, central control which if involved physically in the emergency, renders the entire system useless.

6. Priorities

The three southern cities are covered by repeaters, the first order of priority is coverage for the north shore, Campbellton to Caraquet. This may be accomplished by three separate repeaters at Campbellton, Bathurst and Caraquet, or one single repeater on Mont St. Joseph near New Richmond, Quebec.

The second is for repeaters covering the Edmunston area.

The third, the Chatham-Newcastle area.

The fourth, the St. Stephen-St. Andrews area.

The fifth, the Grand Falls area between the proposed Edmunston and the existing Fredericton repeaters.

The sixth, Sussex area between the existing Moncton, Saint John and Fredericton repeaters.

The seventh, the Tracadie - Shippegan area, Miscou Lighthouse.

The eighth, the $1\frac{1}{4}$ meter repeater system linking the above repeaters.

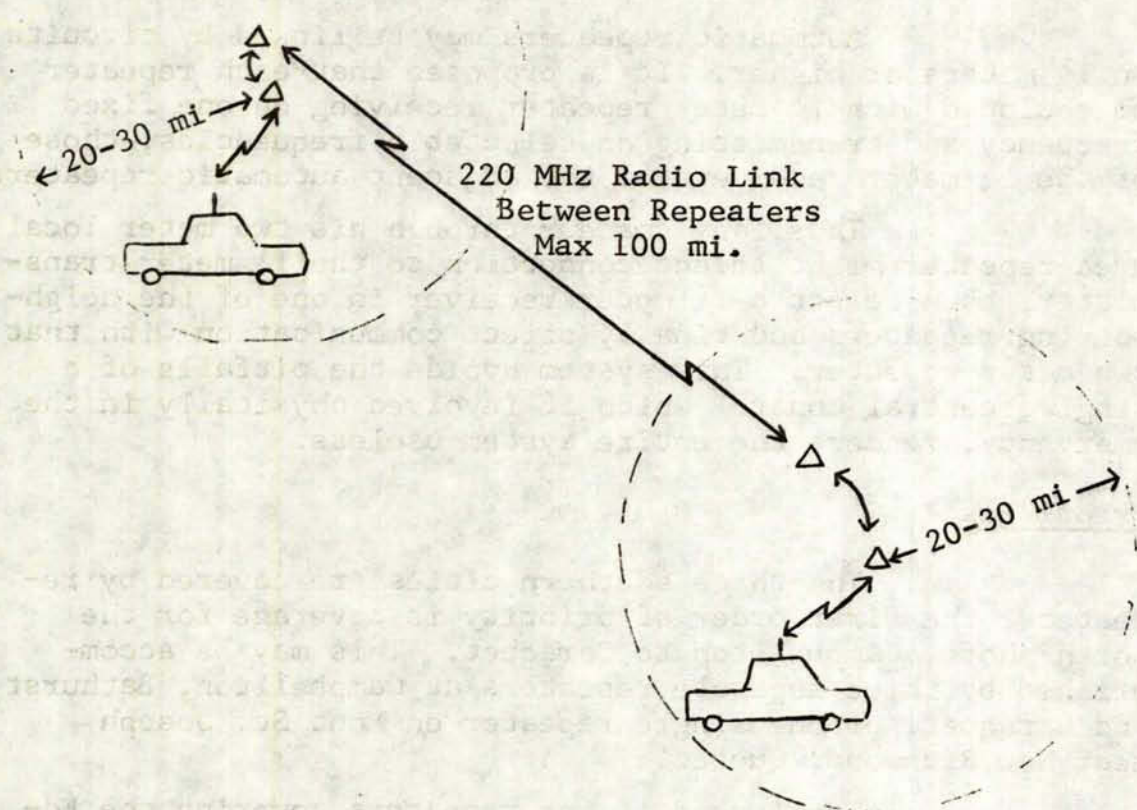

**LINKING REPEATERS TO PROVIDE
REGIONAL COMMUNICATIONS**

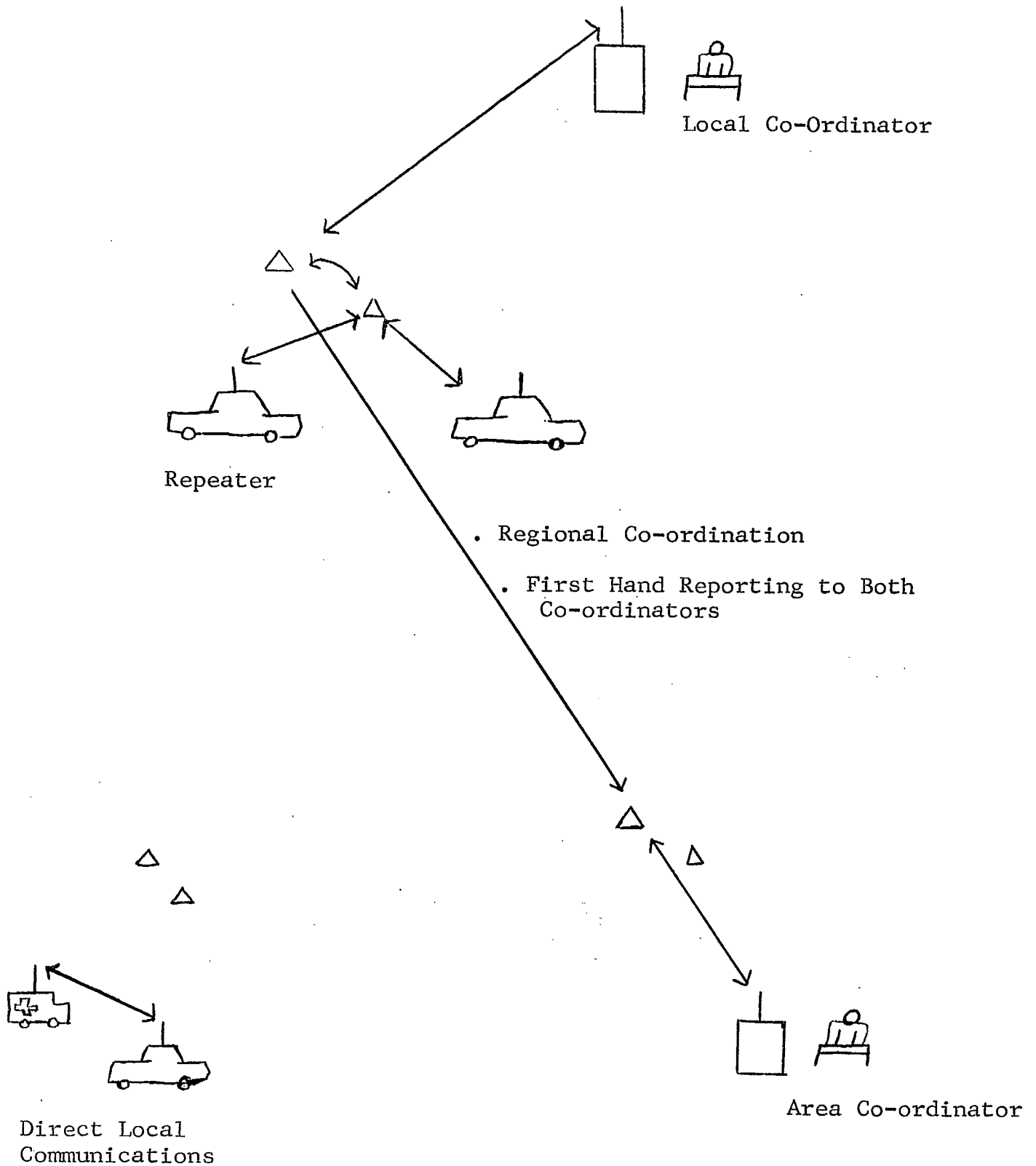

A REPEATER SYSTEM CAN BE
 FLEXIBLE SERVING MANY
 FUNCTIONS SIMULTANEOUSLY

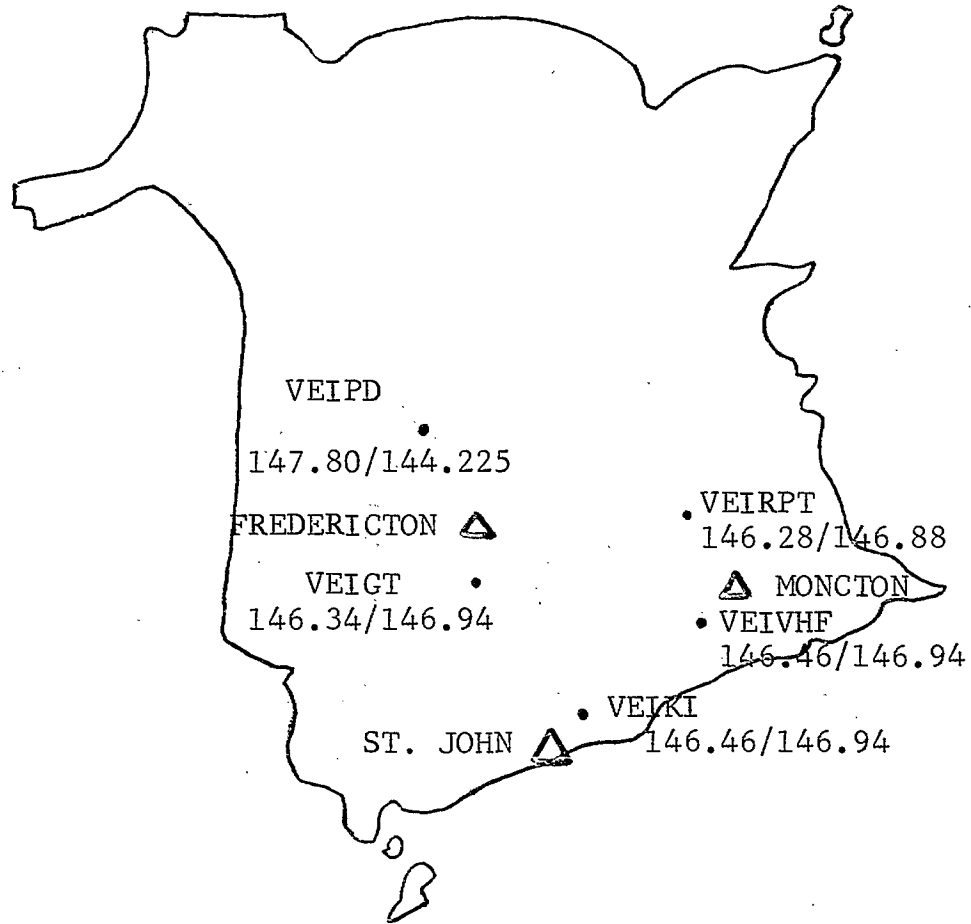

EXISTING
TWO METER
REPEATERS

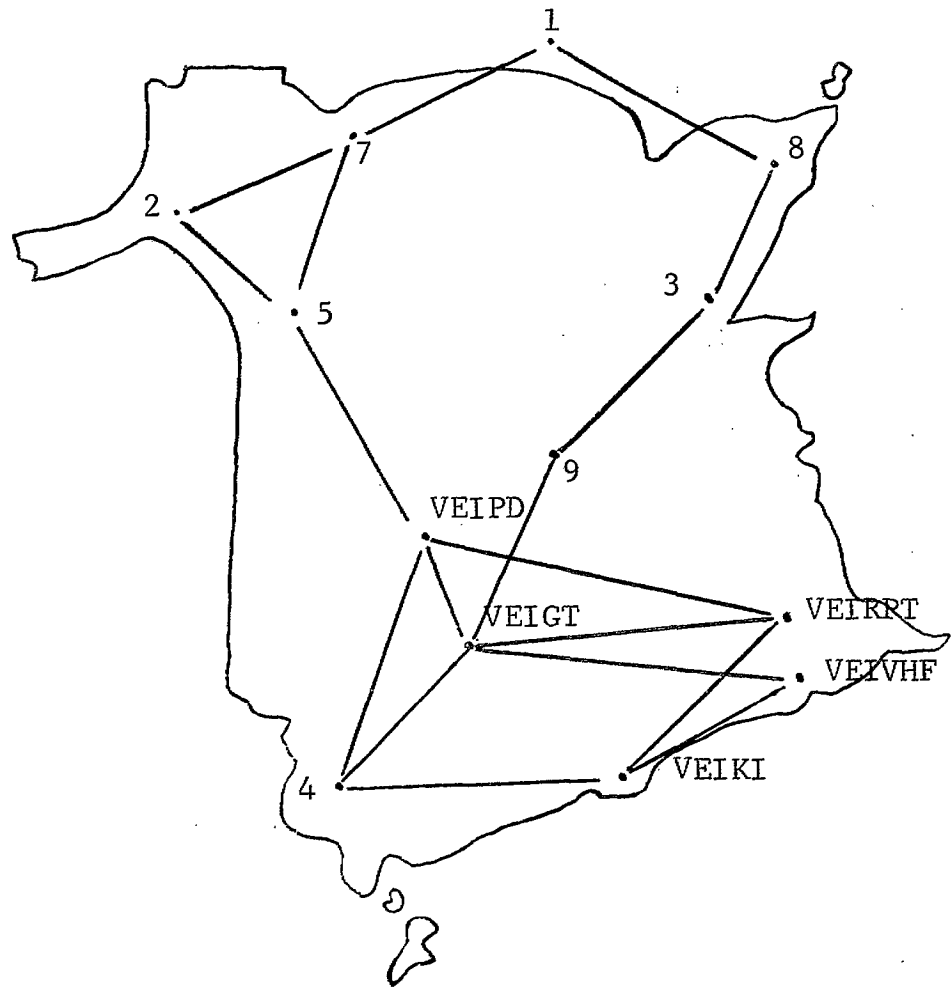

SUGGESTED REPEATER
 LINDS
 FOR REGIONAL
 EMERGENCY COMMUNICATIONS

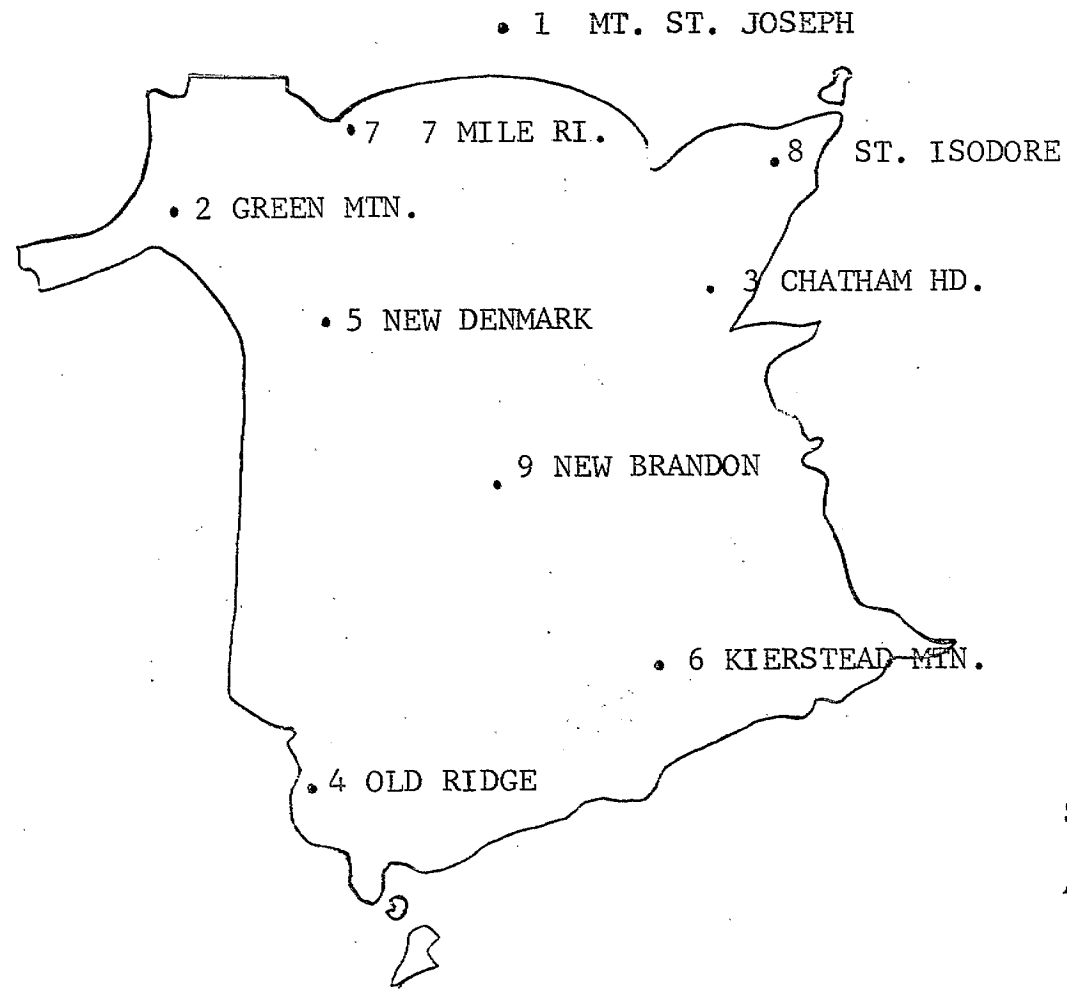

SUGGESTED LOCATIONS
FOR
ADDITIONAL TWO METER
REPEATERS

APPENDIX A

The Radio Act and the regulations thereunder provide for the assignment of several segments of the radio spectrum between 1.8 and 30 MHz to the Amateur Experimental Service. These provide regional and world-wide communications. Provision thereunder is also made for the assignment so that service of several segments above 50 MHz. These latter assignments are not capable of providing more than local communications.

Provision is further made in the Radio Act and regulations, among others, for the reassignment of all Amateur frequencies to the military in the event of a military emergency. Military radio equipment designed for operation below 30 MHz is capable of operating on all of the Amateur frequencies below 30 MHz.

Logic also exists in this reassignment for the removal of the security risk that could exist by permitting amateurs to enjoy world-wide communications capability during a military emergency.

Above 100 MHz essentially all radio equipment of reasonable cost whether military, commercial, utility, amateur or common carrier is crystal controlled. Because of this economic necessity for crystal control, changes in frequency assignments cannot be effected quickly, or without considerable advance planning - current deliveries of crystals in Canada run at least six weeks.

It is submitted that military radio equipment designed for operation above 100 MHz is capable of operation only on presently assigned military frequencies, and that no demonstrable military technical capability presently exists for operation on the Amateur frequencies of 144 to 148 MHz or the others above that frequency.

It is also submitted that because of the lack of capability of these frequencies for long range communications, no more security risk exists for their use in a military emergency than for the continued use of the broadcast media, commercial, utility or common carrier service in the same spectrum for which permission for continued operation is provided.

For what reason then could one argue for the assignment of these frequencies to other than the military in the face of a military emergency?

It is submitted that the Emergency Measures Organization in the Saint John River flood have discovered the need for a separate regional communication system.

The systems of the utilities and the common carriers were taxed to their limit to fulfill their own requirements, and consequently were inadequate to the task imposed by the additional EMO requirements. Supplemental communications were obtained from the Amateur Experimental Service.

The Radio Amateurs of New Brunswick and of Nova Scotia have by their efforts in support of the Emergency Measures Organization in this civil emergency demonstrated that a technical capability exists to provide this supplemental communications. The legal capability for the Amateur Experimental Service to provide this communication in times of civil emergency also exists.

If also during times of military emergency the Emergency Measures Organization could be assured by appropriate and minor revision of the relevant acts, or by assignment to E.M.O. by the military of the Amateur frequency assignments above 144 MHz, the Emergency Measures Organization could be assured of having at its disposal during both civil and military emergencies a continuously demonstrable operating supplemental communications system and a large pool of competent, licenced operators.

F.H. Ryder
B.Sc., M. Eng., P. Eng.,
(M) IEEE, C. Eng., FIEE

May 16, 1973

USE OF AMATEUR REPEATERS IN PEACETIME EMERGENCIES

A.E. Blick, VE3AHU
Communications Officer,
Frontenac-Kingston County (Ont) EMO

GUIDELINES FOR REPEATER OPERATION

Amateurs in Canada began to use auto-repeater facilities to increase the range of mobile operation about ten years ago. Their use has been restricted to bands of frequencies in the VHF region with the majority of stations operating in the 2 metre Amateur band - 146-148 MHz.

There are, as yet, no specific regulations defining the licencing and operation of these stations and their activity is governed by "INTERIM GUIDELINES", the latest of which are those of November 1971. Because without regulations governing their use there is no legal authority governing the existence or use of repeaters the DOC asked the Canadian Amateur Radio Federation to ascertain from their member provincial societies, whether or not the guidelines formed a suitable basis for repeater regulations to be included in the Radio Regulations PART II of the Radio Act. The response from The Amateurs was that they felt that the guidelines allow sufficient freedom of action to ensure future development of this facet of Amateur radio.

As the guidelines stand now they state that:

1. Responsibility for technical operation rests with the licensee and he must maintain a technical log of the station.
2. Three additional Amateurs may be designated as controllers of repeater operation. The DOC be kept informed.
3. The repeater transmitter shall be provided with a means to be automatically disabled when on-the-air time exceeds 5 minutes. Reactivation may be by physical or remote control.

4. Unless specifically authorized by the DOC, the repeater shall not be used for traffic handling except by radio.
5. Amateur repeaters may be controlled by any means - i.e. radio, land-line, physical, etc.
6. All repeaters in the 6 and 2 metre bands shall be identified by a keyed tone transmission of the station call at least every two minutes.
7. Users of repeaters shall identify themselves in the normal manner.
8. Repeater may be used only in the Amateur bands above 50 MHz.
9. Remote control emissions for repeaters shall be in the Amateur bands above 50 MHz.
10. Any link-up of repeaters shall use Amateur frequencies above 220 MHz.

You will note that the Amateurs are allowed a free hand in the specific frequencies used for access and output of repeaters. This unrestricted use of channels has caused problems in some areas but, in the main, these problems have been settled by the Amateurs involved forming Repeater Advisory committees to sit down, discuss problems and work out solutions. There are several channelling plans in existence for 2 metre operation. The one most used is based on a 30 kHz spacing between channels for narrow band (± 7.5 kHz), 60 kHz spacing for wide band (± 15 kHz) channels, with 600 kHz spacing between access and output frequencies.

In this regard, many Amateurs are advocating that a national channel plan be instituted so that it will be possible to travel across Canada on the main travel routes with a minimum of access and output channels with

suitable direct channels for rag-chewing to keep repeater operations for its main requirement - that of increasing the range of mobile operation. The Federation has asked the provincial societies to take a major role in this planning. There is a problem in the costs involved in changing frequencies of existing repeaters when you consider that it costs \$12.00 for a pair of crystals and up to \$150.00 to have cavities and diplexers used by the repeater retuned.

Amateur repeaters are a natural for emergency operation. They give excellent coverage over a local area with normal range being 25 to 50 miles around the site, and with many having emergency power facilities. With the availability of relatively inexpensive solid state equipment, more and more Amateurs are installing 2 metre FM stations and these can be readily used for mobile, base and portable operation using either batteries or AC power and gaining effective range through the use of the repeater. As an example, the number of repeater users in the Kingston, Ontario area has more than tripled in the past three years and a second repeater, VE3KER, has been installed in Kingston in addition to the initial one at Roblin.

In Canada we are blessed with a minimum of restrictions in licencing and operation of these repeaters and we trust that the Amateurs will continue to operate and use these devices with common sense and good judgement. The situation in the USA is different with many restrictions placed on the licencing and operation of repeaters and our fervent hope is that the application of similar restrictions will not be found necessary or desirable in our country.

LIST OF REPEATER OPERATIONS IN CANADA AND NORTHERN U.S.A.

1970

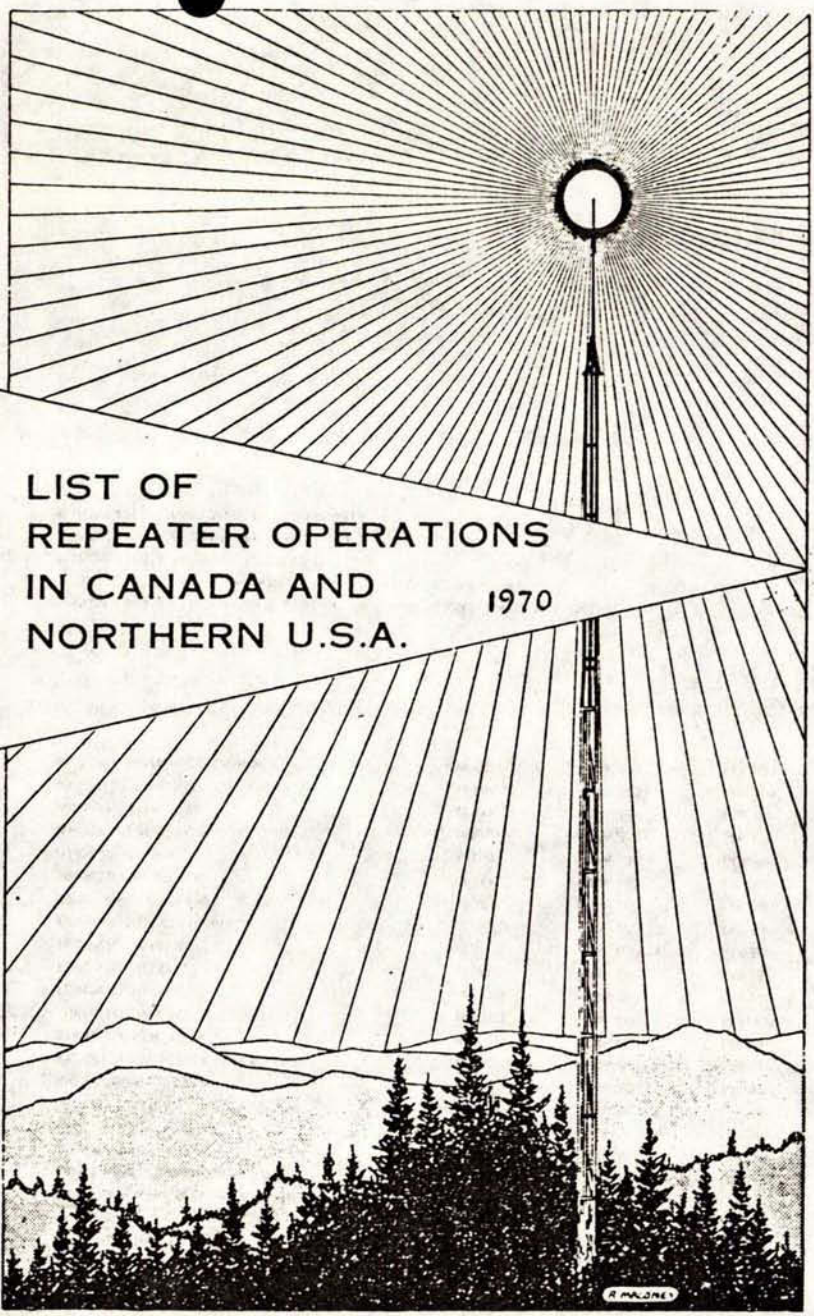

LIST OF 2 METRE REPEATER OPERATIONS IN CANADA AND NORTHERN U.S.A.

(LIST IS TABULATED ACCORDING TO LOCATION)

LOCATION	CALL	INPUT	OUTPUT
BELLEVILLE ONTARIO	VE3KBR	146 460	146 340
BUFFALO NEW YORK	K2LDT	146 310	146 910
CALGARY ALBERTA	VE6AUY	146 460	147 000
CHATHAM ONTARIO	VE3KCR	146 460	146 940
CHICOUTIMI QUEBEC	VE2CRS	146 460	146 940
CHILLIWACK BRITISH COLUMBIA	VE7ELK	147 330	146 580
CONCORD NEW HAMPSHIRE	W1ALE	146 340	146 940
CRANBROOK BRITISH COLUMBIA	VE7CAP	146 340	146 940
DETROIT MICHIGAN	WB8CQS	146 340	146 760
DETROIT MICHIGAN	W8SDZ	146 460	146 640
EDMONTON ALBERTA	VE6WQ	146 460	147 000
ERIE PENNSYLVANIA	W3LZO	146 190	146 790
GRAND FALLS NEWFOUNDLAND	VO1AV	146 460	146 940
GRAND PRAIRIE ALBERTA	VE6OL	146 460	147 000
GRIMSBY ONTARIO	VE3LCR	146 490	147 090
HALIFAX NOVA SCOTIA	VE1ARC	146 460	146 940
HAMILTON ONTARIO	VE3DRW	146 160	146 760
JAMESTOWN NEW YORK	K2TXB	146 280	146 880
JAMESTOWN NEW YORK	K2TXB	146 340	146 880
KILLINGTON VERMONT	W1ABI	146 280	146 940
KITCHENER ONTARIO	VE3KSR	146 370	146 970
LOCKPORT NEW YORK	W2RUI	146 250	146 820
MATANE QUEBEC	VE2CSL	146 460	146 940
MONCTON NEW BRUNSWICK	VE1VHF	146 460	146 940
MONTREAL QUEBEC	VE2CAT	146 180	146 640
MONTREAL QUEBEC	VE2PY	146 280	146 580
MONTREAL QUEBEC	VE2RM	146 400	147 180
MONTREAL QUEBEC	VE2ZO	146 460	147 060
MONTREAL QUEBEC	VE2TA	146 520	147 500
MONTREAL QUEBEC	VE2XW	146 700	147 600
MT MANSFIELD VERMONT	W1KOO	146 350	146 940
NELSON BRITISH COLUMBIA	VE7BTU	146 340	146 940
NIAGARA FALLS ONTARIO	VE3BER	146 070	146 700
OTTAWA ONTARIO	VE2CRA	146 460	146 940
OTTAWA ONTARIO	VE35TP	146 340	147 060
OSHAWA ONTARIO	VE3OSH	146 400	147 120
PETERBORO ONTARIO	VE3PBO	146 340	146 940
PRINCE GEORGE B C	VE7AFG	146 580	147 330
QUEBEC CITY QUEBEC	VE2OM	146 460	146 940
QUEBEC CITY QUEBEC	VE2VD	146 520	147 500
REGINA SASKATCHEWAN	VE5SS	146 460	147 330
RIVIERE DU LOUP QUEBEC	VE2NY	146 460	146 940
ROCHESTER NEW YORK	WA2UWQ	146 340	146 940

LIST OF 2 METRE REPEATER OPERATIONS IN CANADA AND NORTHERN U.S.A.

(LIST IS TABULATED ACCORDING TO FREQUENCY)

(UPDATED OCTOBER 1ST 1970)

LOCATION	CALL	INPUT	OUTPUT
ST CATHERINES, ONTARIO	VE3NRS	146 220	147 240
ST FOY, QUEBEC	VE2LB	146 640	147 140
SAINT JOHN NEW BRUNSWICK	VE1AI	146 460	146 940
SAINT JOHN'S, NEWFOUNDLAND	VO1GI	146 460	146 940
SAULT SAINTE MARIE, ONTARIO	VE3SSM	146 340	146 940
SCHENECTADY, NEW YORK	K2AE	146 460	146 940
SEATTLE, WASHINGTON	W7DBF	146 340 P	146 580
SEATTLE, WASHINGTON	W7DBF	146 760 S	146 580
SHERBROOKE, QUEBEC	VE2FZ	146 460	146 940
SYDNEY, NOVA SCOTIA	VE1JD	146 460	146 940
SYRACUSE, NEW YORK	WA2UWJ	146 460	146 940
TORONTO, ONTARIO	VE3RPI	146 460	147 060 P
TORONTO, ONTARIO	VE3RPI	146 460	146 940 S
TORONTO, ONTARIO	VE3MOJ	146 580	147 180
TORONTO, ONTARIO	VE3SSS	146 640	147 300
TRAIL, BRITISH COLUMBIA	VE7CAQ	146 340	147 330
TROIS RIVIERES, QUEBEC	VE2AI	146 460	146 940
TRURO, NOVA SCOTIA	VE1XK	146 460	146 940
UTICA, NEW YORK	K2GVI	146 340	146 940
WHITEFACE, NEW YORK	WA2UWJ	146 220	146 320
WINNIPEG, MANITOBA	VE4XA	146 460	146 940
VANCOUVER, BRITISH COLUMBIA	VE7ACS	146 340	146 940
VICTORIA, BRITISH COLUMBIA	VE7BFI	146 220	147 540

FREQUENCY	USE	CALL	LOCATION
146 070	INPUT F	VE3BER	NIAGARA FALLS ONTARIO
146 160	INPUT	VE3DRW	HAMILTON ONTARIO
146 180	INPUT	VE2CAT	MONTREAL QUEBEC
146 190	INPUT	W3LZO	ERIÉ PENNSYLVANIA
146 220	INPUT	VE3NRS	ST CATHERINES ONTARIO
146 220	INPUT	VE7BEL	VICTORIA BRITISH COLUMBIA
146 220	INPUT	WA2UWJ	WHITEFACE NEW YORK
146 250	INPUT	W2RUI	LUCKFORD NEW YORK
146 280	INPUT P	K2TXB	JAMESTOWN NEW YORK
146 280	INPUT	W1ABI	NELSON VERMONT
146 280	INPUT	VE2PY	MONTREAL QUEBEC
146 310	INPUT	K2LDT	BUFFALO NEW YORK
146 340	--- U.S.A. NATIONAL REPEATER INPUT FREQUENCY		
146 340	INPUT	W1ALE	CONCORD NEW HAMPSHIRE
146 340	INPUT	WB8CQS	DETOIT MICHIGAN
146 340	INPUT S	K2TXB	JAMESTOWN NEW YORK
146 340	INPUT	W1KOD	MT. MANSFIELD VERMONT
146 340	INPUT	VE7BTU	NELSON BRITISH COLUMBIA
146 340	INPUT	VE3STP	OTTAWA ONTARIO
146 340	INPUT	VE3PBO	PIETERBORO ONTARIO
146 340	INPUT	WA2UWQ	ROCHESTER NEW YORK
146 340	INPUT P	W7DBF	SEATTLE WASHINGTON
146 340	INPUT	VE3SSM	SAULT SAINTE MARIE ONTARIO
146 340	INPUT	VE7CAQ	TRAIL BRITISH COLUMBIA
146 340	INPUT	K2GVI	UTICA NEW YORK
146 340	INPUT	VE7ACS	VANCOUVER BRITISH COLUMBIA
146 370	INPUT	VE3KSR	RITCHENER ONTARIO
146 400	INPUT	VE2RM	MONTREAL QUEBEC
146 400	INPUT	VE3OSH	OSHAWA ONTARIO
146 460	--- CANADIAN NATIONAL REPEATER INPUT FREQUENCY		
146 460	INPUT	VE3NBR	BELLEFLEUR ONTARIO
146 460	INPUT	VE6AUY	CALGARY ALBERTA
146 460	INPUT	VE3KCR	CHATHAM ONTARIO
146 460	INPUT	VE2CRS	CHICOUTIMI QUEBEC
146 340	INPUT	VE7CAP	CRANBROOK BRITISH COLUMBIA
146 460	INPUT	WB8SDZ	DETOIT MICHIGAN
146 460	INPUT	VE6WQ	EDMONTON ALBERTA
146 460	INPUT	VO1AV	GRAND FALLS NEWFOUNDLAND
146 460	INPUT	VE6OL	GRAND PRÉRIE ALBERTA
146 460	INPUT	VE7ARC	HALIFAX NOVA SCOTIA
146 460	INPUT	VE2CSL	MONTREAL QUEBEC
146 460	INPUT	VE1VHF	MONTICLOM NEW BRUNSWICK
146 460	INPUT	VE2ZO	MONTREAL QUEBEC
146 460	INPUT	VE2CRA	OTTAWA ONTARIO
146 460	INPUT	VE2OAT	QUEBEC CITY QUEBEC
146 460	INPUT	VE5SS	REDFORD BRITISH COLUMBIA
146 460	INPUT	VE2NY	REDFORD LOUPOUR QUEBEC
146 460	INPUT	VE1NI	SAINT JOHN NEW BRUNSWICK

INDICATES AN ODDBALL FREQUENCY (NEITHER 60 OR 30 KHZ SPACING)
 * INDICATES A SPLIT CHANNEL FREQUENCY (30 KHZ SPACING)
 P INDICATES A PRIORITY FREQUENCY
 S INDICATES A SECONDARY FREQUENCY
 F INDICATES A FACSIMILE RTTY REPEATER

FREQUENCY	USE	CALL	LOCATION
146 460	INPUT	VO1GT	SAINI JOHN'S, NEWFOUNDLAND
146 460	INPUT	K2AE	SCHENECTADY, NEW YORK
146 460	INPUT	VE2FZ	SHERBROOKE, QUEBEC
146 460	INPUT	VE1JD	SYDNEY, NOVA SCOTIA
146 460	INPUT	WA2UWF	SYRACUSE, NEW YORK
146 460	INPUT	VE3RPT	TORONTO, ONTARIO
146 460	INPUT	VE2AT	TROIS RIVIERES, QUEBEC
146 460	INPUT	VE1XK	TRURO, NOVA SCOTIA
146 460	INPUT	VE4XK	WINNIPEG, MANITOBA
146 490	INPUT	VE3LCR	GRIMSBY, ONTARIO
146 520	INPUT	VE2TA	MONTREAL, QUEBEC
146 520	INPUT	VE2VD	QUEBEC CITY, QUEBEC
146 580	OUTPUT	VE7ELK	CHILLIWACK, BRITISH COLUMBIA
146 580	INPUT	VE7AFG	PRINCE GEORGE, BRITISH COLUMBIA
146 580	INPUT	VE3MOT	TORONTO, ONTARIO
146 580	OUTPUT	W7DBF	SEATTLE, WASHINGTON
146 640	OUTPUT	W8SDZ	DETROIT, MICHIGAN
146 640	OUTPUT	VE2CAT	MONTREAL, QUEBEC
146 640	INPUT	VE2LB	ST FOY, QUEBEC
146 640	INPUT	VE3SSS	TORONTO, ONTARIO
146 700	RTTY		BUFFALO, NEW YORK
146 700	INPUT	VE2XW	MONTREAL, QUEBEC
146 700	OUTPUT F	VE3BER	NIAGARA FALLS, ONTARIO
146 760	*** DIRECT. RAGCHEW - ALL AREAS ***		
146 760	OUTPUT	W8BCQS	DETROIT, MICHIGAN
146 760	OUTPUT	VE3DRW	HAMILTON, ONTARIO
146 760	INPUT S	W7DBF	SEATTLE, WASHINGTON
146 790	OUTPUT	W3LZO	ERIE, PENNSYLVANIA
146 820	OUTPUT	W2RUI	LOCKPORT, NEW YORK
146 820	OUTPUT	WA2UJY	WHITEFACE, NEW YORK
146 880	OUTPUT	K2TXB	JAMESTOWN, NEW YORK
146 880	OUTPUT	VE2PY	MONTREAL, QUEBEC
146 910	OUTPUT	K2LDT	BUFFALO, NEW YORK
146 940	*** NATIONAL CALLING FREQUENCY - ALL AREAS ***		
146 940	OUTPUT	VE3KBR	BELLEVILLE, ONTARIO
146 940	OUTPUT	VE3KCR	CHATHAM, ONTARIO
146 940	OUTPUT	VE2CRS	CHICOUTIMI, QUEBEC
146 940	OUTPUT	W1ALE	CONCORD, NEW HAMPSHIRE
146 940	OUTPUT	VO1AV	GRAND FALLS, NEWFOUNDLAND
146 940	OUTPUT	VE1ARC	HALIFAX, NOVA SCOTIA
146 940	OUTPUT	W1ABI	KILLINGTON, VERMONT
146 940	OUTPUT	VE2CSL	MATANE, QUEBEC
146 940	OUTPUT	VE1VHF	MONCTON, NEW BRUNSWICK
146 940	OUTPUT	W1KOO	MT MANSFIELD, VERMONT
146 940	OUTPUT	VE7BTU	NELSON, BRITISH COLUMBIA
146 940	OUTPUT	VE2CRA	OTTAWA, ONTARIO
146 940	OUTPUT	VE3PBO	PETERBORO, ONTARIO
146 940	OUTPUT	VE2OM	QUEBEC CITY, QUEBEC
146 940	OUTPUT	VE2NY	RIVIERE DU LOUP, QUEBEC
146 940	OUTPUT	WA2UWQ	ROCHESTER, NEW YORK
146 940	OUTPUT	VE1KI	SAINI JOHN'S, NEW BRUNSWICK
146 940	OUTPUT	VO1GT	SAINI JOHN'S, NEWFOUNDLAND

FREQUENCY	USE	CALL	LOCATION
146 940	OUTPUT	VE3SSM	SAGLT SAINTE MARIE, ONTARIO
146 940	OUTPUT	K2AE	SCHENECTADY, NEW YORK
146 940	OUTPUT	VE2FZ	SHERBROOKE, QUEBEC
146 940	OUTPUT	VE1JD	SYDNEY, NOVA SCOTIA
146 940	OUTPUT	WA2UWF	SYRACUSE, NEW YORK
146 940	OUTPUT S	VE3RPT	TORONTO, ONTARIO
146 940	OUTPUT	VE2AT	TROIS RIVIERES, QUEBEC
146 940	OUTPUT	VE1XK	TRURO, NOVA SCOTIA
146 940	OUTPUT	K2GVI	UTICA, NEW YORK
146 940	OUTPUT	VE7ACS	VANCOUVER, BRITISH COLUMBIA
146 940	OUTPUT	VE4XK	WINNIPEG, MANITOBA
146 970 **	OUTPUT	VE3KSR	KITCHENER, ONTARIO
147 000	OUTPUT	VE6AUY	CALGARY, ALBERTA
147 000	OUTPUT	VE6WQ	EDMONTON, ALBERTA
147 000	OUTPUT	VE6LO	GRAND PRAIRIE, ALBERTA
147 060	OUTPUT	VE2ZO	MONTREAL, QUEBEC
147 060	OUTPUT	VE3STP	OTTAWA, ONTARIO
147 060	OUTPUT P	VE3RPT	TORONTO, ONTARIO
147 090 **	OUTPUT	VE3LCR	GRIMSBY, ONTARIO
147 120	OUTPUT	VE3OSH	OSHAWA, ONTARIO
147 140	OUTPUT	VE2LB	ST FOY, QUEBEC
147 180	OUTPUT	VE2RM	MONTREAL, QUEBEC
147 180	OUTPUT	VE3MOT	TORONTO, ONTARIO
147 240	OUTPUT	VE3NRS	ST CATHERINES, ONTARIO
147 300	OUTPUT	VE3SSS	TORONTO, ONTARIO
147 330 **	INPUT	VE7ELK	CHILLIWACK, BRITISH COLUMBIA
146 940	OUTPUT	VE7CAP	CRAWBROOK, BRITISH COLUMBIA
147 330 **	OUTPUT	VE7AFG	PRINCE GEORGE, BRITISH COL
147 330 **	OUTPUT	VE5SS	REGINA, SASKATCHEWAN
147 330 **	OUTPUT	VE7CAQ	TRAIL, BRITISH COLUMBIA
147 360	*** U.S.A. DX INTERCOM FREQUENCY ***		
147 500 *	OUTPUT	VE2TA	MONTREAL, QUEBEC
147 500 *	OUTPUT	VE2VD	QUEBEC CITY, QUEBEC
147 540	OUTPUT	VE7BEL	VICTORIA, BRITISH COLUMBIA
147 600	OUTPUT	VE2XW	MONTREAL, QUEBEC
147 920	*** CANADIAN DX INTERCOM FREQUENCY ***		

* INDICATES AN ODDBALL FREQUENCY (NEITHER 60 OR 30 KHZ SPACING)
 ** INDICATES A SPLIT CHANNEL FREQUENCY (30 KHZ SPACING)
 P INDICATES A PRIORITY FREQUENCY
 S INDICATES A SECONDARY FREQUENCY
 F INDICATES A FACSIMILE RTTY REPEATER

LIST OF 6 METRE REPEATERS IN CANADA AND NORTHERN U.S.A.

(LIST IS TABULATED ACCORDING TO LOCATION)

LOCATION	CALL	INPUT	OUTPUT
OTTAWA ONTARIO	VE2CCC	53 525 A	51 000 A
TORONTO ONTARIO	VE3SIX	52 760	52 525

450 mhz

LIST OF 3/4 METRE REPEATERS IN CANADA AND NORTHERN U.S.A.

(LIST IS TABULATED ACCORDING TO LOCATION)

LOCATION	CALL	INPUT	OUTPUT
MONTREAL QUEBEC	VE2RM	444 000	449 000
OTTAWA ONTARIO	VE2CRA	443 300	448 300

LIST OF 6 METRE REPEATERS IN CANADA AND NORTHERN U.S.A.

(LIST IS TABULATED ACCORDING TO FREQUENCY)

FREQUENCY	USE	CALL	LOCATION
51 000	OUTPUT A	VE2CCC	OTTAWA ONTARIO
52.525	*** NATIONAL CALLING FREQUENCY - ALL AREAS ***		
52 525	OUTPUT	VE3SIX	TORONTO ONTARIO
52 760	INPUT	VE3SIX	TORONTO ONTARIO
53 525	INPUT	VE2CCC	OTTAWA ONTARIO

LIST OF 3/4 METRE REPEATERS IN CANADA AND NORTHERN U.S.A.

(LIST IS TABULATED ACCORDING TO FREQUENCY)

FREQUENCY	USE	CALL	LOCATION
443 30	INPUT	VE2CRA	OTTAWA ONTARIO
444 00	INPUT	VE2RM	MONTREAL QUEBEC
448 30	OUTPUT	VE2CRA	OTTAWA ONTARIO
449 00	OUTPUT	VE2RM	MONTREAL QUEBEC

A INDICATES AN AM REPEATER

"73" MAGAZINE



EDITORIAL BY WAYNE GREEN

PETITION!

The FCC has failed us utterly and completely with the repeater regulations, and we have to make this fact known to them. The principle of "least regulation" has been made a mockery by this over-restrictive set of rules.

Let's make our will known — with a petition. If we can present a petition with several thousand names and calls on it, they will have to listen — and give us relief.

Please make a copy of the below petition and get it signed by as many amateurs as possible — any class of license — and send it to 73 Magazine, Peterborough NH 03458. Please make sure that your petitions are in the mail to me by May 15th, at the very latest. I will make copies of the petitions and send them to the individual FCC Commissioners — to Barry Goldwater — and I will hand carry the originals to the Chief of the Amateur and Citizens Band division.

There are about 1000 repeater groups around the country, and I would hope that we would have 100% cooperation in this from them — which should mean that we could end up with 10,000 to 20,000 signatures. Please do whatever you can — with petitions for signatures in every radio store — at every club meeting, whether it be a repeater club or not. Let's do something this time and let the FCC know that we are interested and that it is important to us.

If we can make ourselves heard, we stand a much better chance of getting attention to our complaints on other legislative matters. If we never take a stand, we are as lost as sheep.

Copies of the petition form are available from 73 Magazine, Peterborough NH 03458 if you send a sase. Please use 8½ x 11 paper and sign on one side only. Please be sure to make the call signs readable.

When you read this, please call in on every repeater you can and see what you can do to organize petition signing meetings — get small committees to go to visit members who can't make the meetings — let's get out the vote using every strategem we can devise. Let's not have any slackers on this.

FCC SHAME

Repeater groups who discover a bootlegger in their midst may in the future think several times before appraising the FCC of this uncomfortable circumstance. The recent events at Phoenix are enough to convince any prudent person that perhaps the last people to be notified in case of such a difficulty is the FCC.

It seems that the trustee of the local repeater discovered that a well known local was a bootlegger when he applied for membership in the club. The first reply said essentially that he should mind his own business. He tried again and eventually the Commission sent two agents to look into the problem — which by the time they arrived had been solved.

The agents turned their attention to the repeaters and were able to find several aspects that weren't in line with the latest rules... so the club had to shut down the repeaters. This brought an eviction notice from the TV station — with the result that three two meter repeaters, one six meter repeater and a 450 repeater went off the air.

One repeater is on part time on 34-94, operating from the trustee's home, when he is home to control it. The 16-76 autopatch machine is on now and then too, but for the most part repeater operation has stopped in Phoenix.

The FCC should be proud of this. It certainly will stand out as a monument to the futility of trying to cooperate with the Commission.

AMATEUR CD RESPONSIBILITY

Not a few amateurs have wondered at the lack of enthusiasm exhibited by our government as far as civil defense is concerned. Talk about benign neglect! Recent information seems to indicate that this is quite intentional — that CD is being left to wither away on purpose.

Continued on p. 119.....

PETITION

I hereby petition the FCC to reconsider docket 18803.

Call	Name	Address	City	State	Zip
W1HUL	Paul Brandon	3 Daniel Webster	Hudson	NH	03051
W1DRP	John C. Tirrell	164 Cypress Ln	Nashua	NH	03060
W1PYF	Samford H. Colby	25 Pine St	L. Hutton	NH	03561
W1WVY	Herman Haberman	11465 Kipling	Nashua	NH	03060
K1CKS	Hugo A.N. Simon	11 G.L. Hill Av.	Everett Mass	Mass	02149
W1TK	A.P. Galt	25 Tushill Ave	Nashua NH	NH	03060
W1VK	John H. Kennedy	19 Bryant Rd	Nashua N.H.	NH	03060
W1GQV	Robert P. Kelly	20 YACMOUTH DR.	NASHUA N.H.	NH	03060
K1ZBJ	Kenneth Pollock	7 Depot St	MERRIMACK	NH	03078
W1LXI	Timothy White	75 Belmont Dr	MERRIMACK	NH	03059
W1JOF	Allen H. Tridder	20 Spruce St	Merrimack	NH	03051
W1BHD	Walter H. Dandish	20 Greenleaf	Merrimack	NH	02145
W1PQR	Charles Knox	42 Summit St	W. Hill N.H.	NH	03055
W1EDG	Richard Manning	22 Wrentham Dr	Hudson NH	NH	03051
K1DDE	Ray H. Gifford	Devonshire Lane	Franklin, N.H.	NH	03040
W1BRK	Robert J. Brown	6511 W. ST	NASHUA NH	NH	03060
K1ACX	Harold F. Stowell	REDA, Box 165	Merrimack, NH	NH	03102
W1FSH	CHET SEATON	701 WEST DR	MERRIMACK, NH	NH	03102
W1LJP	James H. Johnson	1133 W. ST	NASHUA NH	NH	03060
K1GQZ	Jack C. Cannon	46 Royal Ave	NASHUA NH	NH	03060
W1GRH	William J. Cunniff	4 FURST GLEN CIR	WATERMAN MA	MA	01201
W1GDK	John R. Galt	46 Concord St	LAURENS, MA	MA	01451
K1YCN	Robert J. Brown	360 Kingsley Ave	Haverhill Mass	MA	01730
W1RFN	Richard J. Brown	50 W. Hill St	Merrimack, NH	NH	03055
K1MWS	Harold F. Stowell	Waverley Hill	Derby, NH	NH	03038
W1MFK	John A. Simon	Waverley Hill	DERBY NH	NH	03038
W1GQV	John Galt	Rte 136	FRANKLIN, NH	NH	03045
W1ZSA	Wayne Green	1260 North	NH	NH	03458
W1GQV	Robert J. Kelly	20 YACMOUTH DR	NASHUA NH	NH	03060
W1TOX	Ken R. Simon	Peterborough	New Hampshire	NH	03451

..... W2NSD/1 Continued from page 5

The situation seems to be this. part of the nuclear standoff with the Russians appears to be an agreement not to even try to provide any defense measures for the citizens. In return for this, the Russians are expected to reciprocate. By leaving the populations of the two countries unprepared to cope with nuclear war, the standoff results, with each population being held as hostage by the other.

This system seems to work. At least we haven't had the war yet.

I don't recall being asked to agree to this system, and as an involuntary participant, I don't feel all that guilty. If I hedge a bit on the agreement. If you feel the same way, perhaps the following may interest you.

Let's suppose the worst does happen. It could happen by accident — shades of Dr. Strangelove. It could come about through a third party such as China. Somewhere between 50% and 75% of our population would probably be wiped out — perhaps even more. These are the estimates that seem to be accepted by our government.

If such a disaster should come there would be little in the way of communications other than amateur radio. Some of the VHF services could handle purely local traffic, though (as we have found in our run of the mill disasters) each service would probably be too busy with its own communications to provide any help for the population. Even simple things like floods and earthquakes quickly show all existing communications systems to be virtually worthless. Only amateur radio is capable of providing both short and long range communications.

It seems to me that it behooves us to keep this in mind when we are setting up our repeaters and other emergency systems. How many of them will work if the chips ever go down? How reliable will they be? How well prepared are we to use the systems we have set up?

The recent FCC rules on repeaters will make our job of setting up emergency systems many times as difficult — for no obvious reason. This is unfortunate and perhaps we should build in some sort of "A Day" override for the hamstringing requirements of the new regs. Of course there have to be some tests of the full systems — it will be a little late if we wait for it to happen before we start trying to learn how to use things.

Reason dictates that FM repeaters should be able to interconnect with low band transceivers for combined short and long range traffic. Reason dictates that repeaters on the various VHF bands should be able to interconnect so six meter ops can talk with

two meter ops, and with 222 MHz ops — and even with 450 MHz ops. It seems to me to be irrational to have it any other way.

One of the main points where the FCC and I are at odds is that I feel we should be able to set up our repeaters with these systems right now and have them operational. I feel that if there is any pressure for holding down the number of channels in use that this will be felt and economy will follow, that it is not right for the FCC to limit our experimentation and development in the name of possible future channel congestion.

Now I do not suggest that the FCC is part of a conspiracy to prevent adequate civil defense, though they could hardly be much more effective in that direction even if they were consciously working toward inhibiting the development of amateur radio emergency systems. It is extremely unfortunate that the FCC has now set a pattern of turning a totally deaf ear to every plea and request for relief from their overly restrictive rules.

Should the ultimate emergency occur we will need every available aspect of amateur radio. We will need repeaters — every mobile and hand unit we can find — we will need emergency power — sideband rigs to interconnect communities and countries — RTTY for fast message handling — and we will need a measure of cooperation far beyond anything we have ever experienced.

Frankly I would like to see repeater clubs and radio clubs accept the responsibility for preparing for emergencies. I would like to see each club establish one man as an information center — a man who would inventory emergency equipment and personnel available — who would coordinate amateur radio with all other communications services in his community — who would know where to find emergency generators and gas — who would know who to see to interconnect with all other radio users — etc.

Very few repeaters are set up for true emergency operation and this should be remedied as fast as practicable. One of the first things to go in an emergency is commercial power — the other is telephone service. This means that repeaters dependent upon either are of little value in time of trouble.

Automatic gasoline generators are good, to be sure, but they are also expensive and they have to be fed. In a big emergency you might not be able to get to the repeater site to refill the tank — or you might find gas hard to get. Perhaps a better answer for this is to go solid state with the repeater and have it so it will work from 12 volt car or truck batteries when the

commercial power is off. This seems worth some thought and perhaps some articles for 73.

And how about windmill chargers? Maybe we're getting to the point where we might consider them for repeaters — at least as an auxiliary power source. They could help keep the batteries charged.

We could set up the repeaters to operate at about ten watts while on battery power, with the amplifier being connected to the commercial power.

My apologies for getting into nitty gritty aspects — the main idea of this was to communicate my idea about amateurs having a responsibility to provide emergency communications even though CD does not provide much help or encouragement. As I see it the only truly emergency system of communications that the country has is amateur radio — are we going to face up to this responsibility?

REPEATER COUNCIL SPEAKS

It has been reliably reported that at a recent meeting of a statewide repeater council the repeater groups represented agreed unanimously to keep their repeaters on the air should the FCC deadline of June 30th pass without the new call letters being issued. The identifier would be turned off, but the repeaters would continue.

Perhaps it is about time the Commission started reacting reasonably to the needs of amateur radio and stopped its dictatorial stance.

I predict that the pressures will build up to where the FCC must recognize them and modify some of the recent repeater rules... and the interpretations of these rules.

WAYNE vs IRS

Rumors have a way of spreading a lot faster than retractions or denials, so I assume that many readers have heard one or more of the Wayne Green fan club on the air giving a one-sided view of my latest battle with City Hall: the IRS.

The IRS is formidable. They have their own courts — judges — attorneys — and all the money in the world to hassle you. Milton Friedman in a recent *Playboy* feature interview compared the power of the IRS to that which the Russian leaders have over their people... "Or even compared in the United States with the power that an official of the Internal Revenue Service has over you. An official of the IRS can put you in jail. I doubt that there is a person in the United States who couldn't be convicted of technical violation of some aspect of the personal income tax."

Continued on p. 123.....

The following article illustrates the need for a voluntary frequency allocation plan for amateur repeaters.

"73" Magazine

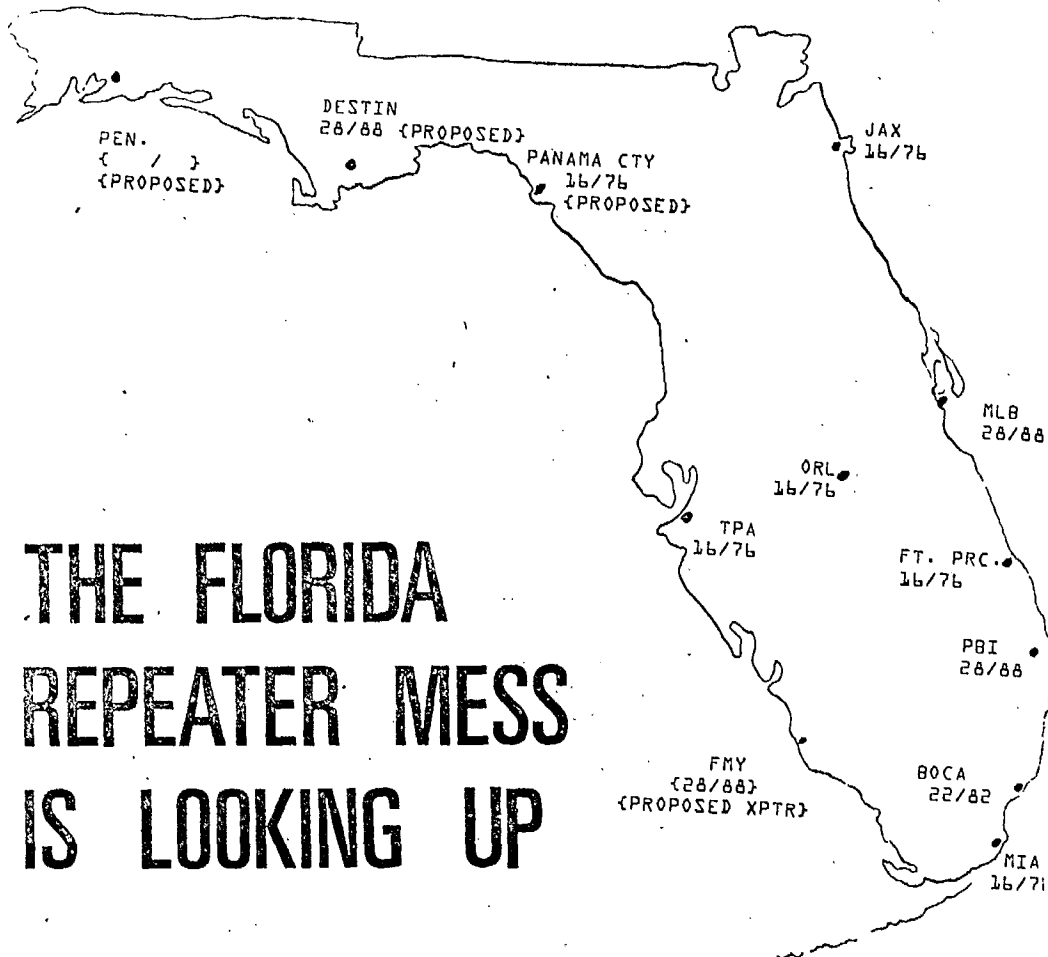

THE FLORIDA REPEATER MESS IS LOOKING UP

Jeffrey R. Harrow WA4RLG
1336 S. Biscayne Pt. Rd.
Miami Beach FL 33141

I'm not all that old (22) and yet, as I look back about six years it seems an immensely long time ago that Glynn WA4LHK, Bill WA4MKD, myself, and the rest of the renowned N.O.M.A.R.C. group put on (to my knowledge) the first amateur two meter repeater in Florida. It consisted of a pre-prog. G.E. into two ground planes up about five stories - and we were ecstatic with a one to two mile range.

Well, as you can see from the sketch, Florida took to two meters with a vengeance. So much so, in fact, that for the past

couple of years, a problem pretty old to the California and New England areas has become evident. With so many repeaters in operation, and with about 90% of them on 34/76, we had the old problem of high powered base stations in Tampa keying the Miami repeater, and vice versa. After a while, the Melbourne repeater came on, and later was joined by the Boca Raton machine, 43 miles north of Miami. It got to the point where most people were shutting off their receivers because they were having to listen to too many one-sided conversations not meant for them.

Then, about eight months ago, the Orlando repeater came on in the center of the state. Poor Melbourne. Poor Tampa. Orlando base stations were consistently keying up their repeaters with 20 dB to full quieting signals. Melbourne even changed their receiver antenna orientation to reduce the problem (and in doing so, though, they removed repeater coverage from a rather barren stretch between Orlando and Melbourne, a nice place to have a flat tire). At the same time down in Miami, the Boca repeater was going strong. It put usable signals into Miami, and communications took on quite an interesting assortment of squeals, grunts, and shouts of "Hey, control station, please shut this &S#4% machine down so I can talk to Boca."

Up to now I've described a situation very familiar (or it may soon be) to most of you. Here is the solution that the South Eastern Repeater Association committee, headed by Hal Greenley K4GYO, proposed, and which was adopted by all of the S.E.U.S. repeaters:

On January 15, 1972, all of the S.E. repeaters changed their main input frequen-

cy to either 146.16, 146.22, or 146.28 MHz. The specific frequency allocations were made by the committee, based on factors including location, seniority, adjacent repeaters, etc. These inputs are "open," that is, no tone coding of any kind. Each repeater also maintains a 146.34 MHz input. This 34 input is Touchtone coded with a different code assigned to each repeater. The code performs a latching function (at the discretion of each repeater) or a time delay. For instance, if the Miami repeater 34 input hears a digit one, it will open, and leave open, the 34 input of the machine, until it hears another digit one, when it will close the 34 input. The 16, 22, or 28 inputs will have priority over the 34 input. So if a station comes on 16, the 16 station will take over, or capture the repeater, even if a station is already transmitting on 34.

Several months later, each repeater will change its output frequency to 146.76, 146.82 and 146.88 MHz respectively.

Now, what have we gained from this mildly expensive and time consuming area-wide change?

(cont'd)

First of all, by careful frequency assignments, mobiles using one repeater will not under normal conditions be able to key up the closest repeater using the same channel. Notice that I said mobiles. What about base stations?

All base stations will be requested to use the 146.34 inputs. This serves several purposes. First and foremost, it allows a mobile, any mobile, and even an HT, to break into a chat by a base station to request help, report accidents, etc. (Remember our justification for existence -- public necessity, interest, and convenience.) Secondly, it allows high powered base stations in Miami for instance, to talk through the Orlando repeater without keying up, or tying up other repeaters around the state. Toward this end, all the individual repeater need do is to keep its 34 input tone coded off when not in use. The repeaters with 34 coded off will not be bothered by the long haul conversation. Of course, two cross-state conversations at once could pose a problem, but then nothing (yet) is perfect. I might also point out that traveling mobiles who can't cram in two more sets of crystals can utilize the 34 input of any repeater he is near with his Touch-tone pad. The only disadvantage for mobile use of 34 is that several repeaters will only operate one centralized 34 receiver while they may have several satellite receivers on their main discrete frequency. Third, if more areas conform to these standardized channels (and they are), only three sets of crystals will be necessary to cover most of the country. Rick WB4IES, and I recently took a light plane trip from Miami to San Francisco and back; we know we missed more repeaters than we worked. Also, the many combinations of PL tones described in several magazines won't be necessary.

This is the beginning of the standardization which is so necessary to our continued expansion. This plan, which you notice incorporates 600 kHz spacing between the repeater transmit and receive frequencies allows more practical one-site repeaters. Another not so obvious advantage is that standard 600 kHz spaced, 60 kHz staggered channels make frequency synthesis somewhat easier to produce.

Certainly there are some objections and disadvantages to this plan. The most often heard seems to be the expense of the new crystals and the fact that "We were here first, why should we move?" Well, the expense, especially in the field of ham radio, is rather minimal. It is interesting to note, however, that most forms of improvement and progress cost some money. This isn't the first and certainly not the last such instance. To the other objection, that of "squatters' rights," I say this: Each motorist on the road has given up some of his freedom -- such as having to stop at a traffic light when he is in a hurry. To go further, the nations of the world have given up some of their freedoms -- such as not indiscriminately testing nuclear weapons. This giving up of "rights" is done in order to bring about the greater good of all. The same thing holds true here. I read a very disturbing article recently where a group of irate two meter hams had a repeater evicted from a beautiful mountain top site because it was bleeding into their receivers 30 kHz and ten miles away. At this, I can only shake my head.

All in all, two meters is growing; well in some areas, and poorly in others. If we all give just a little we may one day see a beautifully interlinked repeater system not only in Florida but extending toward the rest of the country with autopatch facilities and possibly FAX or TV. Atlanta and Florida are even now beginning to talk of a link!. And remember, amateur satellites can do more than broaden our horizons -- they can literally jump them!

Repeaters are becoming more prevalent, and with a consistent, carefully planned system, each repeater will be covering a larger and larger area without bothering its neighbor. And remember, if the FCC receives many complaints from irate repeater groups they could justifiably impose their own rules. We have traditionally been a self-policing group, and it would behoove us to retain this system.

The future? It's governed by what we do today! Remember how the fantastically complex Bell system started.

...WA4RLG

NATIONAL STANDARDIZATION OF REPEATER FREQUENCIES

C.A. (Sonny) GRAY, VE3BTS - Ottawa Amateur Radio Repeater Group

(Written for "The Canadian Amateur",
the official publication of the
Canadian Amateur Radio Federation, Inc.)

One of the problems encountered by Canadian Amateurs today is the lack of standardization of VHF-FM repeaters across the country. I first became aware of the situation when, as a member of the Kingston Amateur Radio Club, I endeavoured to make a list of Canadian and Northern USA repeaters. At that time you needed a total of 37 transmit and/or receive crystals to work Canadian repeaters from coast to coast. This figure was, and still is, unrealistic for the average Amateur.

The situation has mellowed somewhat with some repeaters changing to popular inputs and outputs but the standardization is not there. What is standard? Many feel that repeaters should have 600 KHz spacing between input and output with adjacent channels 60 KHz apart, and I fully agree.

Being involved with emergency communications in the Ottawa area, I was invited to attend the Canada EMO conference held in Arnprior, Ontario in May of this year. Many things were discussed. An open forum was held at the end of the conference and one of the items that came up was my plan for standardization of Canadian repeaters. Why would EMO be interested in this? The subject was brought up by VE3AHU, Art Blick, with whom I had discussed the problem when I had first encountered it. The reason for discussing it at the conference was due to the fact that there were two members of the DOC in attendance. They led us to believe they thought the plan was a viable one.

Some will say it is not a problem with them and I agree there is little problem locally at the present time but with more and more repeaters springing up it is becoming more of a problem every day. Again some will say it is their problem not ours. I do not feel this is the general consensus. I travel quite extensively as do many others but few can afford the large expense for the number of crystals required; consequently the average amateur cannot use a local repeater in cases of emergency or to get directions or just to "meet" some of the locals. I know most of us would like to meet out-of-towners - otherwise most repeaters would have tone access or sub-audible carrier operation.

How do we solve the problem? Simply by using our heads and standardizing repeater frequencies. How do we control the frequencies? Again it is simple. We start at the local level with a repeater group. This could be a club or a committee in a large club. Their prime function would be to improve and maintain the repeater and send delegates to regional repeater councils, which would be the next step. The regional councils could take

in anywhere from two to fifteen repeaters depending on the number of repeaters in the region. This council would consist of one or two delegates from each of the repeater groups. The next step would be provincial councils comprising delegates from the regional councils. Delegates from the provincial councils would form the National Repeater Council.

How would these councils work? Supposing a new repeater is proposed in an area where several repeaters are presently in operation. The repeater group for the new repeater should contact the regional council regarding possible interference with other repeaters. This should take in frequencies, siting (if possible) and power outputs. The council should suggest the best frequency combinations to use in that particular area and the recommended power output to be used. Should the regional councils be concerned with siting and power output? By all means. It is possible that a member of the council may have knowledge of a very good site that could be used for repeater operation which is not known to the local group. On the power output I feel that the surrounding terrain should be considered, the sensitivity of the receiver and antennae used should all be considered. It would be pointless to run 250 watts and cover a large area on transmit if the "ears" of the repeater can only work half as far. Remember the prime function of repeaters is to extend the working range of mobiles. There are several repeaters in use at the present time where the transmitter far outdistances the receiver.

How do the various councils set it all up? The plan I propose goes something like this. We divide the country into squares measuring 100-150 miles on all sides (depending on terrain). Each square is allocated a primary frequency (of which there should be no more than two) and these are alternated going East-West and North-South. In heavily populated areas where more than one repeater is required we issue secondary frequencies on a non-interference basis yet giving all amateurs in the area(s) the best possible coverage. What are the proposed frequencies? They are as follows:

<u>Type</u>	<u>Input</u>	<u>Output</u>
Primary	146.460	147.060
"	146.340	146.940
Secondary	146.280	146.880
"	146.580	147.180
"	146.220	146.820
"	146.520	147.120

I referred to putting the country into squares. It would look something like the diagram below using primaries only. Each square would measure 100-150 miles on each side. Possibly the square would have to be cut down to 50 miles because of the terrain.

34/94	46/06	34/94	46/06	34/94	46/06	34/94
46/06	34/94	46/06	34/94	46/06	34/94	46/06
34/94	46/06	34/94	46/06	34/94	46/06	34/94

Being more familiar with Central and Eastern Canada the map below illustrates the proposed standardization in that region. Remember it is proposed and not as it presently is.

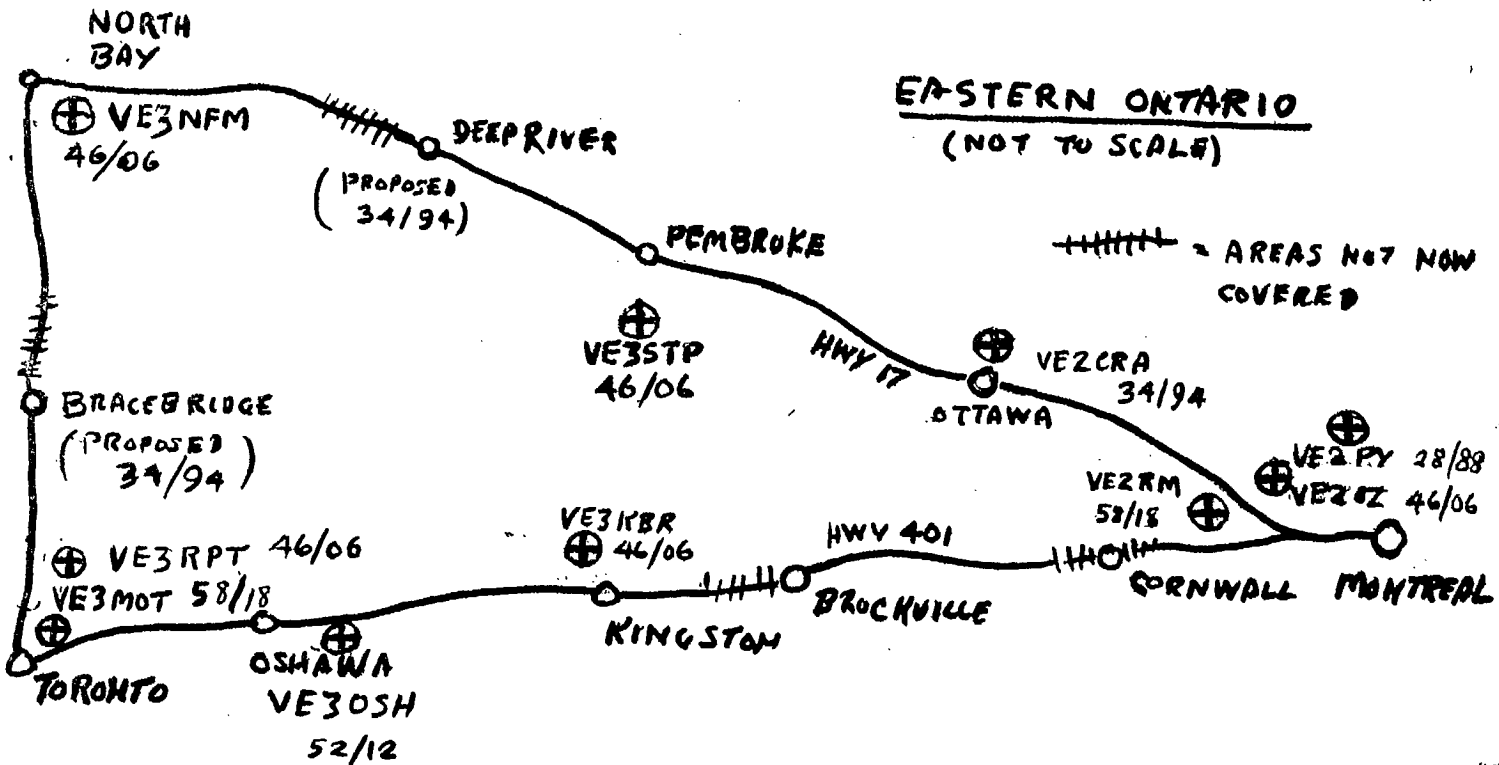

Is it all feasible? Yes, but only if we as amateurs make it work. No one is going to do it for us. Maybe some aren't concerned and rather than get involved with a little work, they will put up with the pending chaos and hcaos it will be, or maybe just simply turn off the rig. Then again maybe some would prefer the DOC to take over and possibly end up with a situation as we have to our South. A few individuals cannot do the job. We must all work together at it. This is a starting point. YOU have to make it work.

ANNEXES - PART II

THE AMATEUR SERVICE IN
EMERGENCY COMMUNICATIONS PLANNING

Annex

- 6 - "Who's In Charge"
 - Frank Purdy (VE3FPF), Toronto, Issue 2, 1973, edition of "The Ontario Amateur".
- 7 - Extracts from "A Guide to Civil Emergency Planning for Municipalities"
 - Canada EMO
- 8 - Extracts from the Radio Act and the Radio Regulations Related to Emergency Communications and the Use of Amateur Radio
- 9 - "The Use of Peacetime Amateur Band Frequencies for Civil Emergency Operations in Wartime"
 - Canada EMO Bulletin No. 7
- 10 - "Use of General Radio Service (GRS) Equipment for Emergency Operations"
 - Canada EMO Bulletin No. 8
- 11 - United States Military Amateur Radio Service (MARS), U.S. Official Publication
and "QST" Magazine, May 1973
- 12 - Extracts from the United States Booklet "Radio Amateur Civil Emergency Service (RACES)"
- 13 - FCC Docket 19723, Notice of Inquiry, April 18, 1973
 - Petitions to FCC to expand VHF frequencies available for RACES purposes. (Some of these conflict with Canada EMO wartime frequency allocations.)

PUBLICATION - "THE ONTARIO AMATEUR" ✓ APRIL-73

WHO'S IN CHARGE

... some thoughts on amateur radio and international emergencies.

— by VE3FPF

(EDITOR'S NOTE: On page 12 of the last issue, the official D.O.C. position on the handling of emergency traffic was given. The question which then arises is:— When you receive this traffic, what do you do with it? Here are some of the answers.)

The earthquake which devastated parts of Nicaragua during the Christmas weekend provided a tragic opportunity for Canadian radio amateurs to demonstrate their willingness to help in an emergency. However, there were times when it seemed no amount of competence and concern was enough to cut through the bureaucratic QRM. Confusion and frustration in trying to clear traffic was expressed on the bands more than once.

In contrast amateurs in the United States were quickly given the authority and access required, with direct phone lines provided to the U.S. State Department in Washington. The Canadian story was quite different. Why?

Who do you call when you have reason to believe you have traffic of national or international importance? What procedures are required to verify sources of information? How and from whom is the necessary authority and coordination obtained? And what can Canadian amateurs do, now, to make better use of their resources before a disaster strikes again?

These were some of the questions being asked, both directly and indirectly that weekend. Lingering still may be some feelings of criticism and resentment about what happened.

WHAT DID HAPPEN?

The Department of External Affairs was on the job night and day, going flat out to meet needs and fulfill Canada's well-earned reputation for helping others. Fred Smith, Coordinator of International Emergency and Relief

with the Department's Canadian International Development Agency said that many staff worked far beyond their physical capacities and in spite of sickness were still on duty when I talked to him a few days later.

Mr. Smith was understanding and helpful when I raised the issues with him. Most of the information that follows came out of our conversation.

The big difference between the United States and Canada is in the way each country responds to a crisis. The U.S. moves bi-laterally while Canada has made multi-lateral commitments. In this instance the U.S. State Department made its own decisions regarding Nicaragua without consultation with any other country or agency. Canada on the other hand handles disaster relief in cooperation with the League of Red Cross organizations. Services such as telecommunications are provided by the Red Cross. Only when their own equipment and operators are on the disaster scene, with communication via Geneva and thence to Ottawa, is traffic accepted.

The Canadian Red Cross dispatched SSB equipment and staff to Nicaragua. They established contact with Geneva who then Telexed appropriate Canadian officials.

WHAT CAN WE DO?

It was suggested that radio amateurs with established contacts over the years would have faster access to competent and credible operators during a civilian emergency. Mr. Smith agreed, and suggested this should be discussed with relevant Canadian authorities in the Departments of Communications, National Defence, and External Affairs.

The Privy Council of Canada has appointed a task force to bring forward recommendations for the better mobilization of communications. This task force is one response to the Stockholm Conference on the Environment which placed some em-

phasis on international communications as one underdeveloped resource.

Heading up the task force is General M. R. Dare whose address is included in the list appended. Perhaps the Canadian Amateur Radio Federation should prepare a brief outlining our experience and concerns, providing an inventory of amateur radio service capabilities, and submit it to the task force. Clearly the objective is not to seek privilege, but better opportunities to serve.

On both the provincial and international scene, the Red Cross is the major agency invested with the responsibility for responding to emergencies and disasters. Perhaps it is time to approach General A. E. Wrinch, commissioner, to initiate discussions regarding communications policies and practices. In Ontario the RSO would be the obvious spokesman for the amateur service. With ONTARS and other nets well established the time for discussion is before the need arises . . . not in the middle of an emergency.

The alternative is unclear goals, overlapping authority, lack of coordination and wasted effort. Without established policies and sustained skills and discipline in handling traffic the best

of intentions will avail us little. Solving the problem could be a unifying activity for the Canadian amateur fraternity and — most important — provide a useful and lifesaving service to others in time of need.

For future reference:—

Department of External Affairs
Coordinator International Emergency & Relief

Mr. Fred Smith. *no answer*
Duty Officer (613) 996-8901

Department of National Defence
Duty Officer (613) 996-7811

Canadian Red Cross
Gen. A. E. Wrinch, Commissioner
Col. Ed. Price, Deputy Commissioner
National Headquarters
95 Wellesley St. E.,
Toronto
(416) 923-6692 *24 hr answering*

Privy Council Task Force on Communications

Gen. M. R. Dare
The Privy Council of Canada
Ottawa, Ont. KIA 0A3

"A Guide to Civil Emergency Planning for Municipalities"

Chapter XXII

This chapter details the communications planning for emergency organizations on the local level and these extracts refer directly or indirectly to the assistance which amateur radio licensees can give to the civic emergency coordinators.

- 15(f) Mobile radio equipment should preferably be installed in municipal vehicles that would be available for emergency purposes. If this is not possible they may be installed in private vehicles which can reasonably be expected to be available at all times but as portable units that can readily be moved to other vehicles.
18. It is desirable that communications officers should have a communications background but it is essential that they have organizational and administrative ability. It is suggested that communications officers might be selected from radio amateurs, ex-military communications officers, employees of commercial communications companies or independently employed persons.
19. Instructors - The communications officer must supervise the training programme. If he is unable to carry out detailed instruction in addition to his other duties, it is essential that a competent instructor be employed on a part-time basis. Amateurs or other volunteers with a communications background should be suitable as instructors.
20. Operators - In an emergency the operating positions must be manned on a twenty-four hour basis and the minimum number required is three persons per position. However, when an emergency occurs, all the trained operators may not be immediately available and it is therefore advisable to train enough operators to provide five operators per position.
21. Before the services of any of these people are relied on for an emergency, it should be ascertained that they will not be required for other duties. Even if in reserved occupations, amateurs will still be available and extremely useful for organization and training in peacetime.
22. All municipal personnel who may have to communicate over the radiotelephone system in an emergency should receive training to the Restricted Radiotelephone Operators (RRO) standard. Telephone as well as radio operators should know voice procedure and circuit discipline so that any operator is capable of operating any position. This can be accomplished by training all communications personnel to the RRO standard. They should also be thoroughly familiar with message writing and handling procedures.
- 29(e). Amateur Networks - Fixed amateur stations in the major urban centres could be extremely useful in an area as backup to a primary system or to provide temporary links to municipalities until a civil emergency network is established. Amateur mobiles could form a reserve to set up emergency links, as required, to municipalities or the emergency services.

SECTIONS OF THE RADIO ACT AND THE GENERAL
RADIO REGULATIONS RELATED TO EMERGENCY
COMMUNICATIONS AND THE USE OF AMATEUR RADIO

The Radio Act 1971

- Sec. 9 (1) Any person...who without lawful excuse interferes with or obstructs any radiocommunication is guilty of an offence and is liable upon summary conviction to fine not exceeding \$2,500 and costs or to imprisonment for a term not exceeding 12 months.
- Sec. 12 (1) Her majesty may at any time assume, and for any length of time retain, possession of any radio station, and of all things necessary to the sufficient working thereof, and may, for the same time, require the exclusive service of the operators and other persons employed in working the same.
- (2) The person owning or controlling the station shall give up possession thereof and the operators and others persons so employed shall during the time of such possession, diligently and faithfully obey such orders, and transmit and receive such signals, calls and radiograms as they are required to receive and transmit by and duly authorized officer of the Government of Canada.

Radio Regulations Part 1

Control of Radio Stations in Cases of Emergency

- Sec. 7 Where in the opinion of the Minister an emergency has arisen in which it is expedient in the public interest that Her Majesty have control over the transmission of messages by the apparatus of any radio station, the Minister may
- (a) by warrant under his hand direct that so much of the apparatus as is within Canada or the territorial waters thereof of any part of the apparatus be taken possession of in the name and on behalf of Her Majesty and be used for Her Majesty's services and subject thereto for such ordinary services as the Minister may prescribe;

- (b) instead of taking possession of the radio station, direct and authorize such persons as he may think fit on behalf of Her Majesty to assume the control of the transmission of messages by the apparatus of the station either wholly or partly and in such manner as he may direct;
- (c) direct the owner of his representative to submit to him or any person authorized by him all messages tendered or arriving by the apparatus or any class or classes of such messages, to stop or delay the transmission of any messages or deliver the same to him or his agent and generally to obey all such instructions with reference to the transmission of messages as the Minister may prescribe and the owner or his representative shall obey and conform to all such instructions; or
- (d) close any radio station and cause the removal therefore of the apparatus or any part of it;

and any person authorized by the Minister for the purpose may enter upon the premises, offices and works of any radio station or any of them and take possession thereof and use the station as directed by the Minister.

Radio Regulations Part II

- Sec. 52 (1) Stations performing an Amateur Experimental Service may be used to communicate only with other stations similarly licensed except that such stations may also be used to transmit signals, communications or energy to receiving apparatus for the measurement of emissions, temporary observations of transmission phenomena, radio control of models and similar experimental purposes.
- (2) All radiotelephone and radiotelegraph transmissions shall be in plain language and shall be limited to messages of a technical nature or of a personal character for which, by reason of their unimportance, recourse to public telecommunications service is not justified but broadcasting is not permitted.
 - (5) Notwithstanding subsection (1), stations performing an Amateur Experimental Service may be permitted to provide communication on behalf of recognized relief agencies during peacetime civil emergencies where no other communication is available.
 - (6) Stations performing an Amateur Experimental Service are forbidden to communicate with amateur stations of countries that have notified the International Telecommunications Union of objection to such communications.

- (7) No station performing an Amateur Experimental Service shall be used for the transmission of international communications on behalf of third parties unless such communications have been authorized by the countries concerned.

Sec. 95 An Emergency Radiotelegraph or Radiotelephone Operator's Certificate may be issued during an emergency for a grade not higher than a Second Class Radio Operator's Certificate to be valid for a period not exceeding six months and the holder of such a certificate may act as a radio operator in the same manner as a provided by a permanent certificate of an equivalent grade.

Sec. 109 Candidates for examination for an Emergency Radiotelegraph Operator's Certificate shall meet the requirements prescribed by the Minister to suit the conditions existing at the time of the emergency.

Extract From "Canadian Amateur Radio Regulations Handbook"
(compiled by CARF in co-operation and consultation with DOC)

II.B.4 PEACETIME EMERGENCY COMMUNICATIONS

Amateur stations may be permitted to provide communications for recognized relief agencies during peacetime civil emergencies where no other means of communications is available.

This presupposes that a State of Emergency has been declared by the responsible municipal authorities, and the Amateur stations should inform the local D.O.C. Radio Office, giving any information that he has regarding the state of local communications, and any commercial facilities that are still available. The D.O.C. will then issue such authorization as they deem necessary.

The authorized station should take care that priority traffic only is handled, and should not handle such traffic as press messages, or personal messages that would not suffer because of delays in their transmission, unless special circumstances prevail.

If the traffic concerns the safety of life, the Amateur can use any means to pass the traffic, but the Amateur should notify the D.O.C. as soon as possible, giving full details of the traffic handled and the means employed. (See attached letter, DOC to CARF Inc., dated January 9, 1973).

The Regional Office of the D.O.C. can be contacted by Amateur Radio... if there are no other means of communication available.



Communications
Canada

Berger Building,
Ottawa, Ontario.
K1A 0C8

Mr. Arthur E. Blick,
President,
The Canadian Amateur
Radio Federation Inc.,
P.O. Box 356,
Kingston, Ontario.
K7L 4W2

Your file Votre référence

Our file Notre référence
6202-6 (RP-2)

January 9, 1973.

Dear Mr. Blick,

This is in reply to your undated letter concerning the interpretation of Section 52(5) of the Amateur Radio Regulations and the responsibility of amateur station licensees to notify the Department of their involvement in civil emergency communications and to obtain approval therefor.

We agree, that in an emergency situation where Amateur radio stations are operating under an approved civil emergency communication plan, E.M.O. officials should notify the local Telecommunications Regulation office of the state of communications. Included, in such approved plans, is Departmental authorization for E.M.O. officials to use the communication facilities of the Amateurs in an emergency so that it is not necessary for amateur stations to individually obtain D.O.C. approval in such cases of emergency.

However, Amateur operators who find themselves the sole means of communication, and who are not included in an approved civil emergency communications plan have the responsibility of notifying the local Telecommunications Regulation office of any emergency operation in which they may participate, as soon as practicable without, of course, delaying their participation in the emergency.

Mr. P.E. Amyot, Chief, Communications, Canada E.M.O. concurs in this approach as it affects E.M.O. and our Regional Offices have been advised accordingly.

In closing, we wish to thank you for your interest in this matter and rest assured that the Department recognizes the positive role played by Amateurs in emergency situations.

Yours truly,

W.W. Scott,
Director,
Regulations Development
Division.

100 Metcalfe Street
Ottawa, Ontario
K1A 0C8

100, rue Metcalfe
Ottawa, Ontario
K1A 0C8

CANADA EMO BULLETIN

BULLETIN NO.: 7

DATE: August 24, 1970

FILE: 1121-2

SUBJECT: Use of Peacetime Amateur Band Frequencies for
Civil Emergency Operations in Wartime

General

1. This Bulletin supersedes EMO Bulletin B-68-4 dated December 1968 and the provisions set out in Sub-section 3.3.4 of the Civil Emergency Communications Manual.
2. Segments of the peacetime amateur bands have been agreed between Canada and the U.S.A. for civil emergency use during a national war emergency only. The Canada-U.S.A. Allocations are shown at Annex "A" to Chapter 3 of the Civil Emergency Communications Manual (EMO Manual No. 10).
3. This Bulletin sets out the procedures to be used to obtain authorization for wartime operation of civil emergency radio equipment on channels within the segments allocated to Canada, in accordance with the frequency plan shown at Schedule "A".
4. a. In the paragraphs that follow, the term "PROVINCIAL ORGANIZATION" applies mutatis mutandis to the Provincial Civil Defence, Emergency Measures, or similar Organization, however termed, or to the Department of Provincial Government charged with the responsibility for the planning and implementation of civil emergency measures within that Province, if no specific organization exists to carry out this function.
b. The term "PROVINCIAL AUTHORITY" applies mutatis mutandis to the Provincial Minister, Deputy Minister or other official however termed, who holds direct responsibility for the operation of the Department or Organization carrying out the civil emergency functions.

Short Form Licences

5. As of January 1st, 1969, all Short Form Licences, issued by the Federal Department of Transport, authorizing the re-activation and operation of amateur radio stations, under civil control, during a national emergency, were cancelled. The following procedure will be used in the future for the purpose of authorizing the operation of amateur radio station equipment during a national emergency only, under civil control.

Authorization of Amateur Radio Station Equipment

6. Amateur radio station equipment to be re-activated will be first specified in provincial or municipal emergency communications plans as set out in paragraph 40, Chapter XXII of "A Guide to Civil Emergency Planning for Municipalities", or in amendments to previously approved provincial or municipal emergency communications plans. Provincial plans or amendments will be submitted to Canada EMO for approval. Municipal plans or amendments will be submitted, in turn, to the Provincial Organization and to Canada EMO for approval.

7. Each plan or amendment will set out the emergency role of the area it covers; describe the emergency operation required to carry out that role; and explain, by means of a narrative, supported by a communications diagram, how the amateur station equipment will be used to support the emergency operation. (Chapter XXII, "A Guide to Civil Emergency Planning for Municipalities", refers.) Preferred operational frequencies and call signs may be shown (Schedule "A" refers) but it will be the responsibility of the Provincial Authority to make the final assignment. The operational call sign will bear no relation or resemblance to the peacetime amateur station call sign and must not have a confusing similarity to the international series. It will be "tactical" in character, consisting of a readily recognized word identifying the net and numerical suffix marking the station.

8. When the plans or amendments have been approved and returned the Provincial Authority will prepare a complete list of the amateur radio station equipment to be re-activated within the Province showing:

- the names and addresses of the licensees,
- the peacetime amateur call signs,
- the geographical location of the fixed equipment,
- the operational area of the mobile equipment,
- the operational frequencies and call signs,
- the serial numbers of the plans or amendments which refer,

and submit it, in three copies, to the nearest Regional Superintendent, Telecommunications Regulations, Department of Communications, for authorization.

9. The Regional Telecommunications Regulations Superintendent will recognize the list as an application from the Provincial Organization to establish and operate its own facilities, at the locations in reference, during a national emergency, i.e., the list will not be regarded as a request to re-activate amateur stations as the latter would, in essence, cease to exist in time of a national war emergency. The Regional Telecommunications Regulations Office will process the list and return two copies to the Provincial Authority with a letter authorizing the Provincial Organization to operate the listed facilities during a national war emergency only.

10. The Provincial Authority will forward one copy to the Canada EMO Regional Director and advise the municipalities concerned.

Provincial and Municipal Government Service

11. Radio stations licensed to perform provincial or municipal government services, which are included in approved civil emergency communications plans, are authorized to operate DURING A NATIONAL EMERGENCY ONLY on the frequencies designated in Schedule "A" for use by Provincial EMO/CD stations.

12. The Provincial Authority will inform the nearest Regional Superintendent, Telecommunications Regulations, Department of Communications, of the details of any plans affecting stations within the jurisdiction of the Regional Office, i.e., a list showing geographical locations, operational frequencies, call signs and licensees will be submitted. The submission should also include a narrative detailing the precautions which will be taken to ensure that radio stations, licensed to perform provincial and municipal government services will not be inadvertently operated on amateur frequencies, during peacetime, by non-amateur-certificated personnel.

Responsibility

13. The Provincial Authority will be responsible for:

- a. allocating operational frequencies in accordance with Schedule "A",
- b. carrying out liaison with other provinces in regard to mutual interference,
- c. allocating operational call signs for the amateur radio stations equipment to be re-activated,
- d. ensuring that all copies of existing Short Form Licences, currently held by municipalities, are collected and destroyed, and
- e. amending the equipment list from time to time, as required.

14. Additions to the list will be processed as set out in paragraphs 8, 9 and 10 above. The Provincial Authority will advise the Regional Superintendent, Telecommunications Regulations, of deletions by letter with a copy to the Canada EMO Regional Director.

15. The Provincial Authority will ensure that the proposed operators, of listed amateur radio equipment, hold appropriate radio operator certificates. (In this context, Sub-section 3.8.1 of the Civil Emergency Communications Manual reads as follows: "All civil emergency radio operators shall hold a professional certificate of proficiency in radio of a grade not lower than a restricted radio telephone operator's certificate. An operator, who holds, in addition to the restricted radio telephone operator's certificate attesting to his

proficiency in radiotelegraphy, may be permitted to employ radiotelegraphy on civil emergency circuits, during a national emergency where such action is required.") It must be understood that the foregoing applies to operation of this equipment in wartime only. Operation of the equipment in peacetime may be carried out only by properly certificated amateurs.

Operation

16. Amateur station equipment operating under Department of Communications authorization during a national war emergency will be subject to all the regulations pertaining to commercial radio stations, with the exception of equipment standards.

17. Amateur stations participating in civil emergency communications during a natural disaster, or during peacetime tests and exercises, require no special authorization, but are subject to all regulations applicable to the amateur experimental service.

18. Amateur stations authorized to operate in wartime under civil control must under no circumstances use their wartime operational call signs in the amateur bands in peacetime.

19. Stations licensed to perform provincial or municipal government services must not be operated, in peacetime, by non-amateur-certificated personnel, on the frequencies listed in Schedule "A". Peacetime tests and exercises may only be carried out on these frequencies by appropriately certificated amateurs under the terms of existing amateur station licences, using the amateur call signs specified therein.

DISTRIBUTION

List "C"

SCHEDULE "A"

OPERATIONAL FREQUENCIES

<u>Band and</u> <u>Frequencies</u>	<u>For Wartime Use By</u>
<u>160 Meters (1800-2000 KHz)</u>	
1878 KHz)	Ex-Amateur Stations
1884 ")	
1903 ")	or
1906 ")	Provincial EMO/CD Stations
<u>80 Meters (3500-4000 KHz)</u>	
3724 KHz	Provincial EMO/CD Stations only
3730 "	" " " "
3736 "	" " " "
3742 "	Ex-Amateur Stations only
3748 "	" " "
3754 "	" " "
3760 "	" " "
3766 "	" " "
3772 "	Provincial EMO/CD Stations only
3778 "	" " " "
3784 "	" " " "
3790 "	" " " "
3796 "	" " " "
<u>40 Meters (7000-7300 KHz)</u>	
7075 KHz)	Provincial
7150 ")	EMO/CD Stations
7160 ")	only
<u>10 Meters (28-28.9 MHz)</u>	
28.76 MHz	Ex-Amateur Stations only
.78 "	" " "
.80 "	" " "
.82 "	" " "
.84 "	" " "
.86 "	" " "
.88 "	" " "
.90 "	" " "
.92 "	" " "
.94 "	" " "
.96 "	" " "
.98 "	" " "

Band and
Frequencies

For Wartime Use By

10 Meters (28-28.9 MHz) Cont'd

	Ex-Amateur Stations only		
29.00 MHz	"	"	"
.02 "	"	"	"
.04 "	"	"	"
.06 "	"	"	"
.10 "	"	"	"
.12 "	"	"	"
.14 "	"	"	"

6 Meters (50-54 MHz)

	Ex-Amateur Stations only		
50.77 MHz	"	"	"
.81 "	"	"	"
.85 "	"	"	"
.89 "	"	"	"
.93 "	"	"	"
.97 "	"	"	"
51.01 MHz	"	"	"
.05 "	"	"	"
.09 "	"	"	"
.13 "	"	"	"
.17 "	"	"	"
.21 "	"	"	"
.25 "	"	"	"
.29 "	"	"	"
.33 "	"	"	"
.37 "	"	"	"
.41 "	"	"	"
.45 "	"	"	"
.49 "	"	"	"
.53 "	"	"	"

2 Meters (144-148 MHz)

	Ex-Amateur Stations only		
145.80 MHz	"	"	"
.86 "	"	"	"
.92 "	"	"	"
.98 "	"	"	"
146.04 MHz	"	"	"
.10 "	"	"	"
.16 "	"	"	"
.22 "	"	"	"
.28 "	"	"	"
.34 "	"	"	"
.40 "	"	"	"
.46 "	"	"	"
.52 "	"	"	"
.58 "	"	"	"
.64 "	"	"	"
.70 "	"	"	"
.76 "	"	"	"

CANADA EMO BULLETIN

BULLETIN NO.: 8

DATE: 12 August, 1970

FILE: 1180-3

SUBJECT: Use of General Radio Service (G.R.S.) Equipment
for Emergency Operations

Introduction

1. In order that Civil Defence/Emergency Measures Organizations may take advantage of available General Radio Service (G.R.S.) equipment in times of emergency, the frequency 27.80 MHz has been set aside by the Department of Communications, on a Canada-wide basis, for emergency use. As this frequency has already been assigned to other users in certain areas, its use by CD/EM Organizations, in these areas, will be on a shared, no protection basis.

2. As licences, permitting the operation of radio communications facilities for emergency purposes, may be issued only to federal, provincial or municipal government authorities, G.R.S. licensees will not be individually authorized to operate on 27.80 MHz. Provincial or municipal governments may however obtain appropriate licences.

Criteria

3. Radio equipment to be operated for civil emergency purposes on 27.80 MHz must meet DOC Radio Standard Specification 120.

4. All radio equipment to be so operated will first be specified in provincial or municipal emergency communications plans as set out in paragraph 40, Chapter XXII of "A Guide to Civil Emergency Planning for Municipalities". Each plan should show by means of a narrative supported by a communications diagram, how the privately owned equipment will be used to support the emergency operation.

5. Each plan or amendment will include a list showing the names, addresses, and call signs of the licensees of the equipment to be used.

Licensing Procedure

6. When the plans or amendments have been approved and returned, provinces and municipalities may apply to the nearest Regional Superintendent, Telecommunications Regulations, for Provincial or Municipal Government Service licences, as appropriate, proposing operation of emergency communications networks on 27.80 MHz. Each licence application may include a number of mobiles sufficient to cover the number of licensees listed in the plan or amendment concerned. A copy of the approved plan or amendment should be filed with the nearest Telecommunications Regulations Field Office of the Department of Communications along with the licence application.

7. Upon receiving the licences, provinces and municipalities may obtain crystals and loan them to the licensees listed in the plans or amendments.

Operation

8. Operators of privately owned radio sets operating under civil control on 27.80 MHz will not use the call signs specified in the licences originally covering their equipment, but will operate as mobiles of the respective provincial or municipal base station, using the base station call sign, plus a mobile number assigned by the CD/EMO authority concerned.

9. Otherwise, all operations must comply in all respects with Sections 70 to 80, Part II of the General Radio Regulations.

Responsibilities

10. Provincial and municipal CD/EMO co-ordinators will be responsible for ensuring that emergency channel (27.80 MHz) is used only for emergency operations under civil control or for CD/EMO training and exercises, and will report any infractions to the Regional Superintendent, Telecommunications Regulations.

11. Provincial and municipal co-ordinators will be responsible for ensuring that all operators, associated with the networks under their jurisdiction, are trained to the Restricted Radio-telephone Operator's Certificate level.

DISTRIBUTION

List "C"

November 24, 1972
NUMBER 4650.2



ASD(T)

Department of Defense Directive

SUBJECT Military Affiliate Radio System (MARS)

- Refs.: (a) DoD Directive 5400.5, "Armed Forces Day,"
December 3, 1965
(b) DoD Directive 4650.2, subject as above,
August 3, 1970 (hereby cancelled)
(c) DoD Instruction 4650.3, "Acquisition Accounting
and Use of Excess Property by the Military
Affiliate Radio System (MARS),"
September 15, 1970

I. PURPOSE

This Directive reissues reference (b) to update policies, outline responsibilities and formalize the composition, mission, functions, organization and support of both the Military Affiliate Radio System (MARS) and Civil Amateur Radio activities within the Department of Defense. Reference (b) is hereby superseded and cancelled.

II. APPLICABILITY

The provisions of this Directive apply to all DoD Components.

III. COMPOSITION

- A. MARS shall be composed of (1) military installation stations, operated and maintained by military personnel under the auspices of a military command, (2) individual stations operated by military or civilian volunteer operators who have reached their fourteenth birthday and possess a radio station capable of operating on radio frequencies assigned to MARS, and (3) military unit or civilian radio club stations operated by individuals who

possess a valid Amateur Radio Operator License. Operators and stations must be licensed by the Federal Communications Commission or be otherwise authorized by competent United States Authority.

- B. Applicants for MARS membership must be citizens of the United States or have been lawfully admitted to the United States for permanent residence under the provisions of Chapter 12 of Title 8, United States Code.

IV. ORGANIZATION

There shall be an organized MARS entity within each of the Military Departments. (The Marine Corps entity will function under the jurisdiction of the Department of the Navy.)

- A. Each Military Department entity will function under the direction of a "Chief, MARS," who will be appointed by the sponsoring Military Department.
- B. The Office of the Secretary of Defense, the Defense Agencies, and appropriate Executive Agencies of the Federal Government may affiliate in a program of a Military Department.

V. MISSION AND FUNCTIONS

- A. The mission of MARS is to provide DoD sponsored emergency communications on a local, national, and international basis as an adjunct to normal communications.
- B. MARS will --
 1. provide auxiliary communications for military, civil and/or disaster officials during periods of emergency;
 2. assist in effecting normal communications under emergency conditions;
 3. handle morale and quasi-official record and voice communications traffic for armed forces and authorized U. S. Government civilian personnel stationed throughout the world;

4. create interest, and furnish a means of training members in military communications procedures;
5. provide a potential reserve of trained radio communications personnel for military duty when needed;
6. maintain and operate the MARS facility on the main Concourse of the Pentagon Building; and
7. conduct an appropriate Amateur Radio program as a part of the annual celebration of Armed Forces Day (see reference (a), DoD Directive 5400.5).

VI. POLICY

It shall be the policy of the Department of Defense to:

- A. Support and encourage MARS and Amateur Radio activities and avoid, within the limitations imposed by military exigencies, any action which would tend to jeopardize the independent prerogatives of the individual Amateur Radio operator.
- B. Encourage and cooperate in the development of amateur and private communications activities to enhance their military and civil value.
- C. Recognize demonstrated technical and operating qualifications of personnel, as evidenced by possession of a valid Amateur Radio License issued by the Federal Communications Commission.
- D. Maintain liaison with all recognized U.S. Amateur Radio organizations and the Federal Communications Commission.

VII. RESPONSIBILITIES

- A. The Assistant Secretary of Defense (Installations and Logistics) shall provide overall guidance and advice in matters relating to the management and standardization of the MARS supply and equipment program (reference (c)).

- B. The Assistant Secretary of Defense (Telecommunications) shall provide overall guidance and advice in matters relating to policy and operations of the MARS program.
- C. The Secretaries of the Military Departments are responsible for the proper management and administration of the MARS to include acquisition, storage, distribution, and accounting for equipment.

VIII. EFFECTIVE DATE AND IMPLEMENTATION

This Directive is effective immediately. DoD Components will review their existing Directives, Instructions, and Regulations for conformity; make necessary changes thereto; and forward two copies of each document to the Assistant Secretary of Defense (Telecommunications) within 90 days.

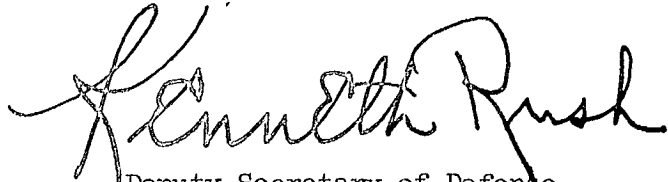
Deputy Secretary of Defense

CHAPTER 1

GENERAL POLICIES

1-1. Purpose. This regulation implements Department of the Defense Directive 4650.2 and prescribes the authority, policy, procedures, and responsibilities for operation of the Department of the Army Military Affiliate Radio System (MARS).

1-2. Explanatory terms. *a. Military installation MARS station.* A MARS station installed, operated and maintained by installation personnel when authorized by the installation commander.

b. Military unit MARS station. A military unit amateur radio station located on a military installation or other real estate under the direct control of any DA activity to include TOE/TDA unit, USAR unit, ROTC instructor groups, and armories under control of the National Guard authorities issued a MARS station license, MARS call sign, and operating on MARS frequencies. Military unit MARS stations or amateur stations may be established in coordination with the installation commander.

1-3. General. *a. Army Military Affiliate Radio System (MARS)* is a program conducted by the Department of the Army in which military installation, military unit, and volunteer licensed US amateur radio stations and operators participate and contribute to the mission of providing auxiliary communications on a local, national, and international basis as an adjunct to normal Department of the Army communications.

b. The Military Amateur Radio System was established on 26 November 1946 by authority of the Secretaries of the Army and Air Force. It was renamed the Military Affiliate Radio System (MARS) on 2 September 1956 to more accurately describe its nature. In August 1962 the Secretary of the Navy approved the Chief of Naval Operations recommendation to organize a Navy-Marine Corps MARS program to be implemented on 1 January 1963. On 3 August 1970 Department of Defense Directive 4650.2 formalized the composition, mission, functions, and the organization of MARS and set forth policies concerning Department of Defense support of MARS and civil amateur radio activities.

c. MARS operates on a joint-service basis for determination of overall policy, practices, and procedures. Operational control and direction is exercised by the Assistant Chief of Staff for Communications-Electronics, Department of the Army; Commander, Naval Communications Command, Department of the Navy; and the Director, Command Control and Communications, Department of the Air Force.

1-4. Policy. *a.* The Department of the Army policy is to support, encourage, and cooperate in the development of MARS and Amateur radio activities so as to enhance their military and civil value; avoid, within limitations imposed by military exigencies, any action which would tend to jeopardize the independent prerogatives of the individual amateur radio operator and maintain liaison with the Departments of the Navy and Air Force, recognized US Amateur Radio organizations, and the Federal Communications Commission, on matters concerning the MARS program.

b. Establishment of Army MARS program activities in a foreign country or territory will be governed by applicable treaties and agreements. Except where prohibited by such agreements, the provisions of this regulation apply. Amateur radio operations by US Army units and personnel in oversea commands are governed by AR 105-70.

c. MARS Army will follow channels of command as prescribed in AR 10-5. For purposes of administrative jurisdiction MARS members residing in the Military District of Washington will be considered a part of the US First Army area. Overseas and CONUS Army area level will act as the executive agents for support, coordination, and execution of the Army MARS program within their geographical areas. They will assure integration of the requirements and plans of other major commands into the total Army MARS program.

1-5. Mission. The mission of Army MARS is to provide auxiliary communications for military, civil and/or disaster officials during periods of emergency; assist in effecting normal communications under emergency conditions; promote

interest, study, and experimentation and furnish a means of training members in military communications; provide a potential reserve of trained radio communications personnel for military service when needed; and handle morale and quasi-official record and voice communications traffic for Armed Forces and authorized civilian personnel worldwide.

1-6. Responsibilities. *a.* The Assistant Chief of Staff for Communications-Electronics (ACSC-E), DA, has Army General Staff responsibility for the Army Military Affiliate Radio System. The ACSC-E will appoint a Chief, MARS, responsible for direction, supervision, and control over the Army-wide MARS program.

b. The Chief, Army MARS will develop, coordinate and disseminate policies, procedures and directives concerning administrative, operational, training and logistical matters for the Army MARS and Amateur Radio programs; direct and supervise the operations of the DA Headquarters MARS Station; maintain liaison with US Government regulatory agencies and recognized US Amateur Radio organizations on matters concerning the DA MARS program.

c. The Commanding General, USASTRAT COM will provide budget and funding support to the Headquarters MARS Army, and provide administrative, logistical, and personnel support to the DA Headquarters MARS Station.

d. The Commander in Chief, US Army Pacific will provide the major MARS radio relay communication facility between the HQDA MARS Station and the various Pacific US Army Headquarters Command MARS Radio Stations.

e. Major Commands will—

(1) Establish and conduct MARS programs and activities in accordance with this regulation and/or plans developed in concert with CONARC.

(2) Designate a Signal Corps Officer or qualified DA civilian employee as the MARS Director for their command. The possession of a current Federal Communications Commission (FCC) Amateur Radio Operators license of general, conditional class or higher while not required, is encouraged.

(3) Plan, program, and budget for requirements, and allocate resources in support of the Command and local MARS programs i.e., administration, logistical support, training, and opera-

tions. Guidance of appropriate staffing guide will be used where applicable.

(4) Appoint an officer, warrant officer, non-commissioned officer, or qualified DA civilian as the military installation MARS officer-in-charge (OIC) who will in addition to his other duties, supervise station operations and conduct training activities under the direction of the Command MARS Director. A station custodian of a military unit amateur radio station, appointed in accordance with this regulation, can be appointed as OIC of the installation MARS station.

f. The Commanding General, CONARC will—

(1) Exercise command responsibilities and direction of the DA MARS program within the CONARC area of responsibility, and coordinate with other major commands to develop, install, operate and maintain an integrated MARS program.

(2) Implement DA guidance to utilize the full potential of the Military Affiliate Radio System in support of natural disaster and civil defense planning and operations within CONUS, and specific emergency and contingency communication responsibilities assigned to CONUS MARS by HQDA continuity of operations plans.

(3) Plan, program, and budget for requirements and allocate resources in support of the Department of the Army MARS program within the CONARC area of responsibility.

(4) Manage the CONUS MARS frequency resources.

(5) Assign responsibilities and tasks to CONUS Army Commanders in support of the Department of the Army MARS objectives in accordance with this regulation.

g. CONUS Army commanders will appoint an individual MARS member who on a volunteer basis, and without remuneration will serve as State MARS Director and, as necessary or desirable, may appoint other volunteer members to be Assistant State MARS Directors. Members without a military obligation or civil emergency commitments will be given preference in these appointments. State MARS Directors will assist MARS Directors, individual MARS members, and installation/unit MARS stations in coordinating and conducting MARS operations and training within their respective states.

h. State adjutants general, in coordination with

the appropriate Army commanders, will administer MARS activities at Army National Guard facilities within their respective areas.

1-7. Funding, planning, and programing. Department of the Army funds are authorized to be expended to support the MARS mission in the

same manner as that authorized for the provision of other communications services and facilities. Planning and programing for major command, major subordinate command, and other installation MARS stations will follow the procedures set forth in AR 105-22.

1973 Armed Forces Day Communication Tests



EACH YEAR on the third Saturday in May, the Department of Defense sponsors the observance of Armed Forces Day. This year's observance, the twenty-fourth, will be held on Saturday, May 19. Once again the Departments of the Army, Navy and Air Force will conduct communication tests between military radio stations and amateur radio stations to demonstrate the partnership and mutual respect enjoyed between the U.S. amateur radio community and the U.S. military.

The tests will consist of military-to-amateur crossband operations, using continuous wave (cw), voice (ssb) and radio-teletypewriter (RTTY) modes of operation and cw and RTTY receiving tests. QSL cards designed especially for this occasion, will be forwarded to those amateurs who establish two-way contact with participating military stations confirming crossband communications. Certificates will be awarded to those who aptly demonstrate their operating ability and technical skill by receiving an acceptable copy of the Secretary of Defense originated cw and/or RTTY message (s) transmitted during the receiving portion of the communication tests. Interception by shortwave listeners (SWL) will not qualify for a QSL card in confirmation of communications. However, anyone who has the equipment and the ability may copy the Secretary of Defense messages and will be eligible to receive a certificate.

Military-to-Amateur Crossband Test

The military-to-amateur crossband operations will be conducted from 19/1300 GMT to 20/0245 GMT. The military stations WAR, NSS, NPG, NØNNN and AIR will transmit on military frequencies and listen for amateur stations transmitting in the portions of the amateur bands indicated below. Additionally, consistent with operational and training commitments, U.S. Navy aircrafts using the call signs NSSAM and NPGAM, will conduct crossband operations on frequencies listed below while flying over various cities. The operators at the military stations will specify that portion of the amateur sub-band they are tuning.

Station	Military Frequency (kHz unless otherwise noted)	Mode	Appropriate Amateur Emission Band (MHz)
WAR (Army Radio Washington, DC)	4001.5	cw	3.5 - 3.65
	4020	lsb	3.775 - 4.0
	4030	RTTY	3.65 - 3.775
	6997.5	cw	7.0 - 7.15
	14405	cw	14.0 - 14.2
	20994	usb	21.25 - 21.45
NSS (Naval Communication Station Washington, DC)	3385	cw	3.5 - 3.65
	4012.5	RTTY	3.65 - 3.775
	4040	lsb	3.775 - 4.0
	6970	lsb	7.15 - 7.3
	7301	cw	7.0 - 7.05
	7380	RTTY	7.1 - 7.15
	7385	cw	7.05 - 7.1
	13827.5	RTTY	14.1 - 14.2
	14385	usb	14.2 - 14.35
14400	cw	14.0 - 14.1	
NSSAM (Navy Aircraft)	27900	usb	28.5 - 29.7
	49.692 MHz	a-m	50.1 - 54.0
	143.820 MHz	a-m	144.1 - 146.0

Aircraft to depart Washington, DC 19/1300 GMT; Providence, R.I. 19/1400 GMT; Buffalo, NY 19/1500 GMT; Indianapolis, Ind. 19/1630 GMT; Memphis, Tenn. 19/1730 GMT; New Orleans, La. 19/1830 GMT; Tallahassee, Fla. 19/1930 GMT; Miami, Fla. 19/2030 GMT; Jacksonville, Fla. 19/2115 GMT; Spartanburg, S.C. 19/2215 GMT; Washington, D.C. 19/2300 GMT.

NPG (Naval Communication Station, San Francisco, Calif.)	4001.5	lsb	3.775 - 4.0
	4005	cw	3.5 - 3.65
	4010	cw	3.65 - 3.75
	6989	cw	7.0 - 7.075
	7301.5	lsb	7.15 - 7.3
	7347.5	RTTY	7.0 - 7.1
	7365	cw	7.075 - 7.150
	13922.5	RTTY	14.0 - 14.15
	14356	usb	14.2 - 14.275
	14375	cw	14.0 - 14.1
	14389	usb	14.275 - 14.35
	20983	cw	21.0 - 21.2

	usb	21.27 - 21.4
* 49.995 MHz	a-m/usb/cw	50.0 - 51.0
* 143.995 MHz	a-m/usb/cw	144.0 - 146.0
** 148.41 MHz	a-m/RTTY	145.0 - 146.0
** 148.95 MHz	fm	146.0 - 148.0
* 222.0	a-m/usb/cw	221.0 - 222.5

* To be operated from Mt. Vaca
 ** To be operated from Mt. Diablo

NPGAM (Navy 148.005 MHz a-m Aircraft) 145.0 - 146.0

The aircraft will be flying from San Francisco to Los Angeles to Seattle and back to San Francisco.

NØNNN (Naval Academy)	4008.5	lsb	3.775 - 4.0
Academy	7350	lsb	7.15 - 7.3
Annapolis, Md.)	13975.5	usb	14.2 - 14.35
AIR (Air Force Radio)	4025	lsb	3.775 - 4.0
Washington, DC)	7305	lsb	7.15 - 7.3
	7315	cw	7.0 - 7.15
	13997.5	cw	14.0 - 14.2
	14397	usb	14.2 - 14.35

Cw Receiving Test

A cw receiving test will be conducted for any person capable of copying International Morse Code at 25 words per minute. The cw broadcast will consist of a special Armed Forces Day message from the Secretary of Defense to all radio amateurs and other participants. The cw broadcast will commence at 20/0300 GMT with a ten minute CQ call for tuning purposes with the Secretary of Defense message commencing precisely at 20/0310 GMT as follows:

Transmitting Station	Frequencies (kHz unless otherwise indicated)
WAR - Army	4030, 6997.5, 14405
NSS - Navy	4012.5, 7385, 14385
NPG - Navy	4005, 6989, 14375, 49.995 MHz, 143.995 MHz
AIR - Air Force	7315, 13997.5

RTTY Receiving Test

A radioteletypewriter RTTY receiving test will be conducted for any individual amateur or station possessing the required equipment. This test of the operator's technical skill in aligning and adjusting

his equipment, serves to demonstrate the growing number of amateurs becoming skilled in this method of rapid communications. The RTTY broadcast will consist of a special Armed Forces Day message from the Secretary of Defense to all radioteletypewriter enthusiasts. The broadcast will be transmitted at 60 words per minute, beginning at 20/0335 GMT with a ten minute CQ call for tuning purposes followed by the Secretary of Defense message at 20/0345 GMT as follows:

Transmitting Station	Frequencies (kHz unless otherwise indicated)
WAR - Army	4030, 6997.5, 14405
NSS - Navy	4012.5, 7385, 14385
NPG - Navy	4010, 7347.5, 13992.5, 148.410 MHz
AIR - Air Force	7315, 13997.5

Submission of Test Entries

Transcriptions should be submitted "as received." No attempt should be made to correct possible transmission errors.

Time, frequency and call sign of the station copied as well as the name, call sign (if any) and address, including zip code of the individual submitting the entry must be indicated on the page containing the test. Each year a large number of acceptable copies are received with insufficient information, thereby precluding the issuance of a certificate.

Entries should be postmarked no later than May 25, 1973 and submitted to: Armed Forces Day Tests, Chief, Navy-Marine Corps MARS, 4401 Massachusetts Avenue, N.W. Washington, DC 20390, Mail Stop 394.

WI9ANG Special Certificates

WI9ANG (Wisconsin 9 Air National Guard) will be on the air May 19 and 20. Special Armed Forces Day Certificates will be issued to all stations worked. The operating schedule for both Saturday and Sunday is: 7.280 MHz, ± 5 kHz, 1330-2130 GMT; 14.310 MHz, ± 5 kHz, 1330-2130 GMT.

To obtain a free certificate your QSL card is required. Send all QSLs to WI9ANG, c/o WA9DZL, 128th Air Refueling Group (TAC), General Mitchell ANG Base, Milwaukee, WI 53207. QST

EXTRACTS FROM THE
MANUAL FOR

Radio Amateur Civil Emergency Service (RACES)

PUBLISHED BY THE U.S. DEPARTMENT OF DEFENSE

and

THE U.S. OFFICE OF CIVIL DEFENSE

December 1971

RADIO AMATEUR CIVIL EMERGENCY SERVICE (RACES)

GENERAL INFORMATION

What is RACES?

RACES is an organization of amateur radio operators who help provide radio communications needed by Federal, State, and local governments in time of emergency. It was created in 1952 primarily to serve in a civil defense emergency, and has since enabled amateur radio operators to perform emergency communications functions as an important supplement to State and local civil defense communications systems. RACES is governed by Subpart F of the Federal Communications Commission (FCC) Rules and Regulations.

When is RACES Used?

RACES may be called upon by the legally appointed Director of Civil Defense or his authorized representative for a particular area (town, city, borough, county, parish, or State) in accordance with an approved civil defense communications plan in any emergency concerning:

- Safety of life
- Preservation of property
- Maintenance of law and order
- Alleviation of human suffering and need
- Dissemination of warnings of enemy attack to the civilian population in case of actual or impending attack
- Any disaster or other incident endangering the public welfare

RACES in Peacetime

Natural disasters often cripple or destroy communications facilities and equipment. RACES members are then asked to handle messages for police, fire, public welfare, public utilities, and other emergency services. RACES members also participate in civil defense exercises in peacetime.

RACES in Wartime

In time of an actual civil defense emergency because of a state of war, stations in RACES will have absolute priority use of specific frequencies within the authorized frequency bands; will be operated under the direct super-

vision of duly designated and responsible officials of the civil defense organization; and will use specific frequencies in accordance with a coordinated local area and adjacent area civil defense communications plan and Subpart F, FCC Rules and Regulations. RACES stations and operators will supplement surviving communications facilities in sending and receiving official emergency information for Federal, State, and local governments. Regular amateur operations will be suspended in time of an actual wartime national civil defense emergency.

How Does RACES Operate?

RACES stations are assigned to one or more radio nets; each net is under a Net Control Station. RACES nets operate under the direction of government officials in accordance with civil defense communications plans. These nets are capable of connecting city emergency operating centers (EOC's) to outlying areas, and providing command and control communications between EOC's at various levels of government.

Who Can Join RACES?

Anyone with an FCC amateur or commercial radio operator license is eligible to become a member of RACES, except the following:

- Those who hold only the Temporary Limited license, or
- The Aircraft Radio Telephone Operator Authorization.

Each operator must hold a valid radio operator license of the proper grade, and a valid written certification by the chief of the local or State Civil Defense organization of the area in which he serves that he has satisfied all Federal, State, and local requirements for enrollment in the Civil Defense organization as a radio operator and is actually enrolled therein. The certification must clearly indicate that a determination has been made as to his loyalty to the United States and general reliability in accordance with the procedures described in the approved civil defense communications plan for the area concerned.

DEVELOPMENT OF A RACES PLAN

A RACES Plan should be drawn up in accordance with the needs of the particular area to be served, and the facilities—including licensed radio operators and stations—available in that particular area. Plans need not be uniform, but must be clearly described in writing and may include diagrams and sketches. A suggested checklist for preparing a RACES Plan follows this section on pages 2 to 5. Completed RACES plans shall be submitted via the State Civil Defense Headquarters to the OCD Regional Office for approval and forwarding to the FCC.

RACES COMMUNICATIONS PLAN CHECKLIST

To satisfy the minimum requirements of the Office of Civil Defense, and Part 97, Subpart F, of the Federal Communications Commission's rules governing the Radio Amateur Civil Emergency Service (RACES), sufficient information to cover every item listed below must be included in a RACES communications plan. If information concerning any of the following items is not presently available, the Plan should so indicate and provisions be made for future amendments to cover or add to such items.

1. Name and describe the area for which civil defense communications are to be provided in the Plan.

2. Name specifically all communities or political subdivisions to be included in a county or an area RACES Plan.

3. Show the name, address, and official title of the persons responsible for coordination of all civil defense activities for the area. The RACES Plan, and all amendments, should bear his signature of approval.

4. Name each civil defense radio officer and any alternates.

a. Show the address, official title, and qualifications of each.

b. If alternates are responsible for various zones of operation within the area, identify the zone or network for which each is responsible.

5. Describe the *facilities* available to the area and the *procedures* to be followed in determining the *loyalty* and general *reliability* of all persons connected with the RACES organization. All radio operators must hold written certification, signed by the local civil defense director, that they have been investigated and meet the necessary loyalty and reliability stand-

ards, before operation in the RACES is permitted.

6. Give the number of networks planned for the area.

a. Show the area to be served by each network and give the purpose of each (i.e., command, first aid, radiological, etc.).

b. Describe how facilities will be organized for command and operational purposes.

(1) From local to area or State control.

(2) From local to lower echelons.

(3) Coordination with police, fire, engineering, medical, rescue, and other services.

(4) List frequencies to be used by the various services, and for what purpose (point-to-point, base, mobile, and portable).

(5) Describe how this Plan is coordinated with existing adjacent area requirements. Indicate whether or not mutual aid and mobile support have been considered.

c. Show the call sign to be used by each net control station and each alternate net control station. Give the address from which each will operate. Indicate any shelter protection against fallout and emergency power, if available, along with the number of days fuel on hand.

d. Show the address of all proposed fixed stations. Indicate the network(s) in which each will be operated.

e. Describe briefly the communications equipment to be used.

f. Give the estimated number of portable and mobile units expected to be used in each network.

g. Indicate which of the stations, units, networks, and operators will be immediately available, and which are planned for the future.

h. Show the method to be used in assigning call signs to units (i.e., will the same call sign, with numbers appended be used for all units under one station authorization for the Plan; will each *network* request station authorization; or will each *unit* request a separate station authorization?).

(1) Show the method of assigning call signs to portable and mobile units.

(2) Give tactical call signs, if any, that will be used.

(3) Describe types of codes and cipher systems, if any, that will be used.

i. Describe the method and authority which will be provided for liaison and coordination of frequency usage with other

similar networks in the same and adjacent areas to provide efficient sharing of frequencies and avoid, or eliminate, interference. This description must clearly state that your civil defense organization will resolve all RACES frequency-sharing problems within its own area of operation and resolve, with civil defense organizations in other areas, any mutual RACES frequency-sharing problems, present or future.

7. If any change is made in a RACES organization which would alter the information submitted in the original plan, the plan should be amended to show the change. All RACES communications plans and any later amendments must be submitted to the Federal Communications Commission via the proper State and OCD Regional authorities for their approval.

8. Documentation needed in connection with Authorization and Certification requirements:

a. A completed FCC Form 482 for the Radio Officer is to be submitted with the

Plan. (Ref: Section 97.171, Subpart F, FCC Rules and Regulations).

b. A completed FCC Form 481 for each RACES station listed in the Plan is to be submitted with the Plan. (Ref: Section 97.181, Subpart F, FCC Rules and Regulations).

c. A certification fulfilling the requirements of FCC Rules and Regulations, Part 97, Subpart F, referred to in Section 97.203 (a) therein, will be issued to each operator under the Plan.

d. Samples of FCC Form 481 and FCC Form 482 are shown on pages 4, and 5.

NOTE:

Separate amateur station licenses will not be issued to civil defense or RACES organizations. Bona fide amateur clubs desiring station licenses primarily for regular amateur activities may use their stations for RACES operations.

**FREQUENCY ALLOCATION PLAN
FOR
RADIO AMATEUR CIVIL EMERGENCY SERVICE (RACES)**

INTRODUCTION

a. This outlines a frequency allocation plan for stations in the Radio Amateur Civil Emergency Service (RACES). The plan is designed to:

(1) Minimize communications interference; and

(2) Provide maximum use of those amateur frequencies earmarked for civil defense communications (RACES) during an alert, natural disaster, or national emergency, as directed by civil defense authority. In peacetime, stations in RACES share these frequencies with the regular amateur service.

b. Channel separation for VHF bands (Table 10) have been revised in order to gain additional frequencies. For efficient use of the allocated frequency spectrum, during a national emergency, proper application of the Quadrant System and frequency assignment must be achieved by each local RACES group. Conversion cost may be eligible for Federal contributions if applicants comply with the criteria outlined in this plan and meet the requirements prescribed for eligibility to participate in Federal contributions programs for Civil Defense purposes. Applications must be accompanied by a current OCD/FCC RACES plan reflecting the changes in RACES channelization.

c. The Federal Communications Commission (FCC) has indicated that incentive licensing program will have no effect whatever on operation in the RACES program. Duly authorized RACES stations may continue to be operated for tests, drills, and actual emergencies pursuant to an approved civil defense communications plan, and in accordance with Part 97, Subpart F of the FCC Rules and Regulations without limitation as to operator class license. Specially, the limitations of Section 97.7 do not apply to RACES. Section 97.165 provides the exemption. Reservations of certain portions of the amateur "bands" for operators holding advanced or extra class licenses do not apply to RACES operations.

GENERAL PRINCIPLES OF ALLOCATION

a. Longer range frequencies have been allocated to States for civil defense operations. Distances involved in State-wide networks which tie State control centers to remote area control centers require frequencies in both the 3.5 and 7.0 MHz bands, and on occasion may require the use of the 14, 21, & 28 MHz bands. Local communities, metropolitan areas, and counties or parishes can achieve efficient communications by using frequencies in the 50, 144, and 220 MHz bands, without encountering long-range interference inherent in the 3.5 and 7.0 MHz band operation.

b. Continuous wave (CW) frequencies in the 3.5 and 7.0 MHz ranges are assigned to States to effect a clear channel for each State on both bands. In addition to these specific assignments, other channels have been assigned by OCD on a geographical minimum interference basis. FCC Rules and Regulations state in part: "The transmitting equipment of a radio station in this service shall be adjusted in such manner as to produce the minimum radiation necessary to carry out the communications desired." RACES stations must recognize that long range frequencies shared with other States will require the adjustment of transmitter power output during periods of good radio propagation and nighttime use.

c. With the implementation of NACOM II High Frequency SSB System between State-to-OCD Regional Headquarters, RACES frequencies previously assigned for this operation are now allocated for State use. Where Region-to-State NACOM II is not yet in existence or as a third order backup, Regions will operate as member stations in the States network.

MODIFICATION REQUIREMENTS

a. Presently approved RACES plans are valid until January 1, 1973. Operations may continue on assigned frequencies until that date unless a plan is modified. If a plan is modified, it must conform to the particulars set forth in

this directive. RACES plans that do not conform with this directive must be modified by January 1, 1973 or they will be cancelled by OCD.

b. Upon issuance of this plan, all RACES applications received by OCD for new or modified plans, using radiotelephone and radio telegraph frequencies made available in FCC Rules and Regulations, Part 97, Subpart F, must comply with this frequency allocation plan.

REMOTE CONTROL OF AMATEUR (REPEATER) STATIONS

Part 97, Amateur Radio Service Rules, does not provide for the unattended operation of an amateur (repeater) station used to automatically receive and retransmit signals from other amateur stations. Operation with a properly licensed operator in attendance at the so-called repeater station or at an authorized remote control point is permissible provided the requirements of applicable rules, including Section 97.43 of the FCC Rules and Regulations, are met. Control of any remotely controlled transmitter(s) must be exercised by the licensee by wire line or radio link (220-225 MHz) from a fixed remote control point. Radio control links for RACES operation must be in the 220-225 MHz band since higher frequency amateur bands are not authorized for RACES operation.

AUTHORIZED EMISSIONS

a. Authorized emissions and their definitions follow:

Symbol		Authorized Band Width
(1) 0.1A1	Continuous Wave telegraphy	100 hertz
(2) 1.1F1	Frequency shift telegraphy	1 KHz
(3) 3A3A	Single side band telephone reduced carrier	3 KHz
(4) 6A2	Telegraphy amplitude modulated at audio frequency	6 KHz
(5) 6A3	Double sideband telephony	6 KHz
(6) 6A4	Amplitude modulated facsimile	6 KHz
(7) 6F2	Telegraphy frequency modulated at audio frequency	6 KHz

Symbol		Authorized Band Width
(8) 6F3	Narrow band frequency or phase modulated telephony	6 KHz
(9) 20F3	*Wide band frequency or phase modulated telephony	20 KHz

* Although FCC Rules and Regulations authorizes the use of 40F3 for RACES operations, OCD requires that the band width of this emission be either reduced to 20 KHz or employ 6F3 emission in order to provide for additional channelization and prevent harmful interference to other stations in the Radio Amateur Civil Emergency Service.

b. Side band frequencies resulting from keying or modulating a carrier wave shall be confined within the authorized amateur band.

c. Frequency tolerance, purity and stability of emissions will be in accordance with good engineering and operational practices.

FREQUENCY ALLOCATIONS

a. 1800-2000 KHz. Frequencies in this band are subject to the LORAN system of radio navigation priority and to the geographical, frequency, emission, and power limitations contained in Section 97.193 of the FCC rules governing amateur radio service. Cancellation of RACES authorizations for any or all frequencies in this band may be necessary or desirable owing to the priority of the LORAN system. However, in coordination with adjacent areas, selection of specific frequencies should be based on Table 1.

TABLE 1

Channelization for 1800-2000 KHz

Frequency (KHz)	
Telephony (3A3A—SSB—upper sideband)	Telegraph (0.1A1, 1.1F1)
1805.5 1980.5	1801.0 1976.0
1809.0 1984.0	1802.0 1977.0
1812.5 1987.5	1803.0 1978.0
1816.0 1991.0	1804.0 1979.0
1819.5 1994.5	1823.0 1998.0
	1824.0 1999.0

b. 3500-3550 KHz. Assignments shown in Table 2 provide each state with a primary frequency in this band for radiotelegraph use.

TABLE 2
Channelization for radiotelegraph
3500-3550 KHz
(Emission—0.1A1, 1.1F1)

Frequency (KHz)	State	Frequency (KHz)	State
3500.5	Washington	3524.5	Kentucky
3501.5	Rhode Island	3525.5	Utah
3502.5	Iowa	3526.5	Connecticut
3503.5	Virginia	3527.5	Kansas
3504.5	Nevada	3528.5	Michigan
3505.5	West Virginia	3529.5	Louisiana
3506.5	Alaska—	3530.5	Maine
	Virgin Islands	3531.5	Missouri
3507.5	Hawaii—	3532.5	South Carolina
	Puerto Rico	3533.5	Montana
3508.5	Mississippi	3534.5	New Jersey
3509.5	North Carolina	3535.5	Arkansas
3510.5	New York	3536.5	Georgia
3511.5	North Dakota	3537.5	Wyoming
3512.5	Illinois	3538.5	Pennsylvania
3513.5	Arizona	3539.5	Oklahoma
3514.5	New Hampshire	3540.5	Alabama
3515.5	South Dakota	3541.5	Colorado
3516.5	Tennessee	3542.5	Delaware
3517.5	Idaho	3543.5	Texas
3518.5	Vermont	3544.5	Indiana
3519.5	Minnesota	3545.5	California
3520.5	Ohio	3546.5	Florida
3521.5	Oregon	3547.5	Maryland
3522.5	Massachusetts	3548.5	Wisconsin
3523.5	Nebraska	3549.5	New Mexico

NOTE: Frequencies in the 3516-3550 KHz band are limited to the first 30 days of an actual Civil Defense emergency, unless otherwise ordered by the FCC.

c. 3987.5-3999.5 KHz. Channels in this band shown in Table 3 are intended primarily for use as calling frequencies for each State to establish initial contact or on matters requiring coordination. After initial contact has been established, exchange of traffic should take place on some other channel or circuit. Net Control Station should limit the use of these channels to high priority traffic and communications with adjacent areas of bordering States.

TABLE 3
Channelization for radiotelephone
3987.5-3999.5 KHz
(3997.0 KHz—0.1A1, 3A3)*
(Emission—[3A3A] SSB [lower sideband]
0.1A1, 1.1F1)

Frequency KHz	States
3987.5	Massachusetts, Delaware, North Carolina, Ohio, Mississippi, Kansas, South Dakota, Illinois, Utah, Washington
3990.5	Vermont, Rhode Island, Virginia, Tennessee, Florida, Arkansas, Michigan, Iowa, Colorado, Arizona, Idaho
3993.5	New York, Maine, Maryland, Kentucky, South Carolina, Louisiana, Missouri, Hawaii, Wisconsin, Oregon, New Mexico
3996.5	New Jersey, West Virginia, Alabama, Indiana, Texas, North Dakota, Nevada, Alaska, Virgin Islands, Wyoming
3999.5	Connecticut, New Hampshire, Pennsylvania, Georgia, Minnesota, Oklahoma, California, Puerto Rico, Nebraska, Montana

* The 3997.0 KHz frequency is for use in emergency areas when required to make initial contact with military units.

d. 7097.5-7100.5 KHz. Frequencies assigned to States in this band provide a radiotelegraph frequency in the 7 MHz band for State-to-area use (see Table 4).

TABLE 4
Channelization for radiotelegraph
7097.5-7100.5 KHz
(Emission—0.1A1, 1.1F1)

Frequency KHz	States
7097.5	New Mexico, Kentucky, New Jersey, Mississippi, Nebraska, California, Rhode Island
7098.0	Louisiana, Virginia, Connecticut, Georgia, Indiana, South Dakota, Nevada
7098.5	Texas, Ohio, Vermont, North Carolina, Minnesota, Kansas, Idaho
7099.0	Arkansas, Maryland, New Hampshire, Florida, Michigan, Iowa, Utah
7099.5	Pennsylvania, Maine, South Carolina, Illinois, North Dakota, Oregon, Arizona
7100.0	Oklahoma, West Virginia, Massachusetts, Alabama, Wyoming, Missouri, Washington
7100.5	Delaware, New York, Tennessee, Wisconsin, Colorado, Montana

e. 7101.0-7124.5 KHz. Frequency allocation provides each State (except Alaska and Hawaii) with a radiotelegraph channel in the 7.0 MHz portion of the band, as shown in Table 5.

TABLE 5
Channelization for radiotelegraph
7101.0-7124.5 KHz
(Emission— ϕ .1A1, 1.1F1)

Frequency KHz	State	Frequency KHz	State
7101.0	Rhode Island	7113.0	Missouri
7101.5	Mississippi	7113.5	South Carolina
7102.0	Washington	7114.0	Montana
7102.5	New York	7114.5	New Jersey
7103.0	North Dakota	7115.0	Arkansas
7103.5	West Virginia	7115.5	Georgia
7104.0	Arizona	7116.0	Wyoming
7104.5	New Hampshire	7116.5	Pennsylvania
7105.0	South Dakota	7117.0	Oklahoma
7105.5	Tennessee	7117.5	Alabama
7106.0	Idaho	7118.0	Colorado
7106.5	Vermont	7118.5	Delaware
7107.0	Minnesota	7119.0	Texas
7107.5	Ohio	7119.5	Indiana
7108.0	Oregon	7120.0	California
7108.5	Massachusetts	7120.5	Maryland
7109.0	Nebraska	7121.0	Wisconsin
7109.5	Kentucky	7121.5	Florida
7110.0	Utah	7122.0	New Mexico
7110.5	Connecticut	7122.5	Virginia
7111.0	Kansas	7123.0	Louisiana
7111.5	Michigan	7123.5	Illinois
7112.0	Nevada	7124.0	Iowa
7112.5	Maine	7124.5	North Carolina

NOTE: Frequencies in the 7103-7126 KHz band are limited to the first 30 days of an actual Civil Defense emergency, unless otherwise ordered by the FCC.

f. 7248.5-7254.5 KHz. Channels in this band are intended as a State-to-State headquarters or statewide calling frequency. Due to increased activity and interference, nighttime operation as well as general use will be limited. Since this band will provide only three SSB voice channels, prior frequency allocation to States has not been made. Each application for a specific channel assignment must be accompanied by a detailed justification. The appropriate OCD Region will then coordinate and determine channel assignments to minimize mutual interference. See Table 6.

TABLE 6
Channelization for radiotelephone

7248.5-7254.5 KHz
(Emission—[3A3A]—SSB [lower sideband]
 ϕ .1A1, 1.1F1)

Frequency (KHz)
7248.5
7251.5
7254.5

NOTE: Frequencies in the 7246-7247 and 7253-7255 KHz band are limited to the first 30 days of an actual Civil Defense emergency, unless otherwise ordered by the FCC.

g. 14047.5-14052.5 KHz. Assignment of this band, shown in Table 7, provides each State (except Alaska and Hawaii) with a radiotelegraph frequency in the 14 MHz band for State-to-area or State-to-State use.

TABLE 7
Channelization for radiotelegraph

14047.5-14052.5 KHz
(Emission— ϕ .1A1, 1.1F1)

Frequency KHz	State
14047.5	New Jersey, Tennessee, Minnesota, Colorado
14048.0	Vermont, Virginia, Arkansas, Oregon
14048.5	West Virginia, Alabama, Michigan, Kansas, Utah
14049.0	New York, Ohio, Oklahoma, North Dakota
14049.5	Rhode Island, Delaware, Mississippi, Wisconsin, Wyoming
14050.0	Kentucky, Texas, South Dakota, Idaho
14050.5	California, Iowa, New Hampshire, Florida
14051.0	Pennsylvania, Georgia, Illinois, Nevada
14051.5	Massachusetts, South Carolina, New Mexico, Missouri, Montana
14052.0	Maryland, Indiana, Nebraska, Arizona, Maine
14052.5	Connecticut, North Carolina, Louisiana, Washington

h. 14220.5-14226.5 KHz. Channels in this band are intended as a State-to-State headquarters or statewide calling frequency. Due to increased activity and interference, nighttime operation as well as general use will be limited. Since this band will provide only three SSB voice channels, prior frequency allocation to States has not been made. Each application for a specific channel assignment must be accompanied by a detailed justification. The appropriate OCD Region will then coordinate and determine channel assignments to minimize mutual interference. See Table 8.

TABLE 8
Channelization for radiotelephone
14220.5-14226.5 KHz
 (Emission—[3A3A]—SSB—[upper sideband])
 0.1A1, 1.1F1)

Frequency (KHz)
14220.5
14223.5
14226.5

NOTE: Frequencies in the 14220-14222 and 14228-14230 KHz bands are limited to the first 30 days of actual Civil Defense emergency, unless otherwise ordered by the FCC.

i. **21047.5-21052.5 KHz.** Frequencies assigned to States in this band provide a radiotelegraph frequency in the 21 MHz band for State-to-area or State-to-State use. See Table 9.

TABLE 9
Channelization for radiotelegraph
21047.5-21052.5 KHz
 (Emission—0.1A1, 1.1F1)

Frequency KHz	States
21047.5	New Jersey, Tennessee, Minnesota, Colorado
21048.0	Vermont, Virginia, Arkansas, Oregon
21048.5	West Virginia, Alabama, Michigan, Kansas, Utah
21049.0	New York, Ohio, Oklahoma, North Dakota
21049.5	Rhode Island, Delaware, Mississippi, Wisconsin, Wyoming
21050.0	Kentucky, Texas, South Dakota, Idaho
21050.5	California, Iowa, New Hampshire, Florida
21051.0	Pennsylvania, Georgia, Illinois, Nevada
21051.5	Massachusetts, South Carolina, New Mexico, Missouri, Montana
21052.0	Maryland, Indiana, Nebraska, Arizona, Maine
21052.5	Connecticut, North Carolina, Louisiana, Washington

j. *Mutual Interference.* In the event of mutual interference on any of the listed bands, stations will report such interference to the appropriate OCD Regional Office through their local Civil Defense Director. The OCD Regional Office will then coordinate and determine new channel assignments to prevent further interference.

k. *VHF Bands.* VHF bands are defined in this plan as the 6, 2, and 1¼-meter bands. The FCC has designated only a few channels for civil defense operation in the RACES segments of the amateur bands. Therefore, it is essential

that the States have a plan to achieve internal coordination of these allotted frequencies and assign them according to need. The VHF bands including 10 meters have been divided into channels with the frequency separations shown in Table 10.

TABLE 10
Channelization for 10 meters and VHF bands

Band (meters)	Frequency MHz	Channel Separation (KHz)
10	28	10
6	50	15
2	144	15
1¼	220	30

QUADRANT SYSTEM

a. *Quadrant System*

The quadrant system is used in making local frequency assignments. If this plan is applied with good judgment, a minimum of adjacent area interference problems will result. Careful consideration must be given to the receiving characteristics of the particular equipment used.

b. *Principles of the Quadrant System*

(1) Each State is divided into quadrants of approximately equal size. The division lines can follow political boundaries—or in some cases natural boundaries. Where necessary, and if the state areas are of sufficient size, these larger quadrants may be subdivided into smaller quadrant systems. This subdivision may take place several times until the distance across any quadrant shall not be less than the normal ground wave distance of the frequency considered.

(2) To determine quadrant sizes, the following ground wave distances are recommended:

- (a) 10 meters—each quadrant system 60 miles, each quadrant 30 miles.
- (b) 6 meters—each quadrant system 60 miles, each quadrant 30 miles.
- (c) 2 meters—each quadrant system 30 miles, each quadrant 15 miles.
- (d) 1¼ meters—each quadrant system 30 miles, each quadrant 15 miles.

(3) Each quadrant system shall be designated as follows (operates in clockwise direction):

- A—Northwest
- B—Northeast
- D—Southwest
- C—Southeast



CHART NO. 1 SUGGESTED METHOD OF QUADRANT SUBDIVISION

(4) All the channels in each band are then inserted in clockwise rotation into these quadrants, starting with Quadrant A. (See Tables 11, 12, 13, and 14.) No break should occur in rotation of these assignments. When the low band channels are exhausted, the rotation continues immediately with the high band group rather than restarting in Quadrant A.

(5) The channels for basic statewide use are then crossed off the quadrant together with any other channels that would—because of their assignment for State use in adjacent States—cause an interference problem near adjacent State borders. The remaining channels in each quadrant may be reassigned.

c. Recording of Channel Assignments

(1) Local frequency assignments are the responsibility of each State. However, the State also is responsible for maintaining a complete record of all VHF bands and 10 meter assignments to avoid interference.

(2) States requiring 10-, 6-, 2-, and 1¼-meter channels are responsible for advising local communities which channels they may use and which VHF and 10 meter channels are reserved for State operations.

d. OCD Regions may grant waivers from the use of the quadrant system upon receipt of sufficient justification. The justification must include documents showing coordination and concurrence by the affected political jurisdictions and a detailed explanation of the hardship or problems that would otherwise be encountered.

OPERATION OF THE QUADRANT SYSTEM

a. Chart 1 shows the methods of operation of the Quadrant System. For example, Indiana is divided into approximately equal quadrants:

- (1) The northwestern section of the State is designated as Quadrant A;
- (2) The northeastern section of the State is Quadrant B;
- (3) The southeastern section of the State is Quadrant C; and
- (4) The southwestern section of the State is Quadrant D.

b. Quadrant subdivisions, in general, incorporating political entities, should be selected to meet individual State and local needs.

CHANNELIZATION

a. 10-Meter Band Frequencies (28.56–28.74 and 29.46–29.64 MHz).

- (1) Frequencies available for assignment

in Quadrants A, B, C, and D are selected from Table 11.

- (2) Quadrant A. 10-meter band frequencies assignable are any of the ten frequencies from 28.56 MHz to 29.63 MHz.
- (3) Quadrant B. 10-meter band frequencies assignable are any of the ten frequencies from 28.57 MHz to 29.64 MHz.
- (4) Quadrant C. 10-meter band frequencies assignable are any of the nine frequencies from 28.58 MHz to 29.61 MHz.
- (5) Quadrant D. 10-meter band frequencies assignable are any of the nine frequencies from 28.59 MHz to 29.62 MHz.

b. 6-Meter Band Frequencies (50.35–50.75 MHz and 53.85–75 MHz). Assignments in the 6-meter band frequencies are made in the same manner as in the 10-meter band, but the 6-meter band frequencies are selected from Table 12, which shows the assignments for the respective quadrants.

c. 2-Meter Band Frequencies (145.20–145.68 MHz and 146.82–147.33 MHz). Assignments in this band are made in the same manner as in the 10-meter band, but the 2-meter band frequencies are selected from Table 13, which shows the 2-meter band assignments for the respective quadrants.

d. 1¼-Meter Band Frequencies (220–225 MHz). Assignments in this band are made in the same manner as in the 10-meter band, but the 1¼-meter band frequencies are selected from Table 14, which shows the 1¼-meter band assignments for the respective quadrants.

SUBDIVISION OF THE QUADRANT SYSTEM

a. A State requiring additional communications channels may subdivide each of the quadrants into additional quadrants as shown in Chart 1 in the example for Illinois. By this subdivision, the original Quadrant A, located in the northwestern section of the State is subdivided into quadrants, and the frequencies shown in Tables 11, 12, 13, and 14 can be reassigned in three additional areas of the State. Therefore, Quadrant A frequencies in the 10-, 6-, 2-, and 1¼-meter bands may be used in four separate areas of the State. This subdivision also permits using frequencies available for assignment in Quadrants B, C, and D in three additional areas of the State. OCD recommends that quadrants be spaced a minimum of 30 miles for satisfactory operation in the 10-meter band.

Therefore, the subdivision shown for Illinois should be well within the ground wave limitations of the 10-, 6-, 2-, and 1¼-meter bands. (See "Principles of the Quadrant System," page 42).

b. A densely populated State or area requiring additional frequencies for communications may again subdivide any of these quadrants into additional quadrants, as shown in Chart 1. For example, in the southeastern section of Iowa, the B Quadrant for the subdivided C Quadrant may be again subdivided into quadrants. For example, if this subdivision is employed in all the 16 secondary quadrants in Iowa, all the frequencies in the A Quadrants shown in Tables 11, 12, 13, and 14 are assignable in 64 individual areas of the State. Also, the frequencies assignable in B, C, and D Quadrants can be reassigned in 64 locations,

c. States having a low population density will require relatively few frequencies and therefore may not require subdivision into smaller quadrants.

d. Mountainous States having relatively short communications distances should utilize, where practicable, repeater type operation in the 1¼-meter band. This would eliminate the need for lower frequencies and possible interference with adjacent states. (See Paragraph 4.)

e. Quadrant subdivisions may be made as many times as practicable, based upon the recommended ground wave distances outlined in "Principles of the Quadrant System," page 42. The State radio officer must use good judgment when assigning frequencies in any particular quadrant subdivision to prevent communications interference with adjacent States.

TABLE 11

*Allocation of 10-Meter Frequencies **

RACES channels for use by States, counties, and other local governments

(Emission: 28.56-28.74 MHz—0.1A1, 6A3, 6F3, 6A4
29.46-29.64 MHz—0.1A1, 1.1F1, 6A3, 6A4, 6F3)

Quadrant A		Quadrant B	
<i>Channel Designation</i>	<i>Frequency in Megahertz</i>	<i>Channel Designation</i>	<i>Frequency in Megahertz</i>
1	28.56	1	28.57
2	28.60	2	28.61
3	28.64	3	28.65
4	28.68	4	28.69
5	28.72	5	28.73
6	29.47	6	29.48
7	29.51	7	29.52
8	29.55	8	29.56
9	29.59	9	29.60
10	29.63	10	29.64

Quadrant D		Quadrant C	
<i>Channel Designation</i>	<i>Frequency in Megahertz</i>	<i>Channel Designation</i>	<i>Frequency in Megahertz</i>
1	28.59	1	28.58
2	28.63	2	28.62
3	28.67	3	28.66
4	28.71	4	28.70
5	29.46	5	28.74
6	29.50	6	29.49
7	29.54	7	29.53
8	29.58	8	29.57
9	29.62	9	29.61

* Operation of the Quadrant System is in clockwise Direction. (See Chart 1.)

A3 includes single and double sideband with full, reduced or suppressed carrier.

TABLE 12

*Allocation of 6-Meter Frequencies **

RACES channels for use by States, counties, and other local governments

(Emission: 50.35 MHz-50.75 MHz—0.1A1, 6A2, 6F2, 6A3, 6F3, 6A4, 53.35 MHz-53.75 MHz—0.1A1, 1.1F1, 6A2, 6F2, 6A3, 6A4, 6F3, 20F3, 53.30 MHz-20F3)**

Quadrant A		Quadrant B	
<i>Channel Designation</i>	<i>Frequency in Megahertz</i>	<i>Channel Designation</i>	<i>Frequency in Megahertz</i>
1	50.36	1	50.375
2	50.42	2	50.435
3	50.48	3	50.495
4	50.54	4	50.555
5	50.60	5	50.615
6	50.66	6	50.675
7	50.72	7	50.735
8	53.39	8	53.405
9	53.45	9	53.465
10	53.51	10	53.525
11	53.57	11	53.585
12	53.63	12	53.645
13	53.69	13	53.705

Quadrant D		Quadrant C	
<i>Channel Designation</i>	<i>Frequency in Megahertz</i>	<i>Channel Designation</i>	<i>Frequency in Megahertz</i>
1	50.405	1	50.39
2	50.465	2	50.45
3	50.525	3	50.51
4	50.585	4	50.57
5	50.645	5	50.63
6	50.705	6	50.69
7	53.375	7	53.36
8	53.435	8	53.42
9	53.495	9	53.48
10	53.555	10	53.54
11	53.615	11	53.60
12	53.675	12	53.66
13	53.735	13	53.72

* Operation of the Quadrant System is in clockwise Direction. (See Chart 1.)

** The 53.30 MHz frequency is available in emergency areas for initial contact with military units and for communications with military stations.

TABLE 13

Allocation of 2-Meter Frequencies *

RACES channels for use by States, counties, and local governments

(Emissions: 145.20-145.68 MHz-0.1A1, 1.1F1, 6A2, 6F2, 6A3, 6A4, 6F3 (20F3)**
 146.82-147.33 MHz-0.1A1, 1.1F1, 6A2, 6F2, 6A3, 6A4, 6F3 (20F3)**)

Channel Designation	Quadrant A Frequency in Megahertz	Quadrant B Frequency in Megahertz	Quadrant C Frequency in Megahertz	Quadrant D Frequency in Megahertz
1	145.20	145.215	145.23	145.245
2	145.26	145.275	145.29	145.305
3	145.32	145.335	145.35	145.365
4	145.38	145.395	145.41	145.425
5	145.44	145.455	145.47	145.485
6	145.50	145.515	145.53	145.545
7	145.56	145.575	145.59	145.605
8	145.62	145.635	145.65	145.665
9	145.68 <i>CDN</i>	146.82	146.835	146.85
10	146.865	146.88	146.895	146.91
11	146.925	146.94	146.955	146.97
12	146.985	147.00	147.015	147.03
13	147.045	147.06	147.075	147.09
14	147.105	147.12	147.135	147.15
15	147.165	147.18	147.195	147.21
16	147.225	147.24	147.255	147.27
17	147.285	147.30		

* Operation of the Quadrant System is in clockwise direction. (See Chart 1.)

** Limited use only.

CDN - 145.80 - 146.76

TABLE 14

Allocation of 1 1/4-Meter Frequencies *
 RACES channels for use by States, counties, and local governments

(Emissions: 220.00-225.00 MHz-9.1A1, 1.1F1, 6A2, 6F2, 6A3, 6F3, 6A4, 20F3)

Channel Designation	Quadrant A Frequency in Megahertz	Quadrant B Frequency in Megahertz	Quadrant C Frequency in Megahertz	Quadrant D Frequency in Megahertz
1	220.030	220.060	220.090	220.120
2	220.150	220.180	220.210	220.240
3	220.270	220.300	220.330	220.360
4	220.390	220.420	220.450	220.480
5	220.510	220.540	220.570	220.600
6	220.630	220.660	220.690	220.720
7	220.750	220.780	220.810	220.840
8	220.870	220.900	220.930	220.960
9	220.990	221.020	221.050	221.080
10	221.110	221.140	221.170	221.200
11	221.230	221.260	221.290	221.320
12	221.350	221.380	221.410	221.440
13	221.470	221.500	221.530	221.560
14	221.590	221.620	221.650	221.680
15	221.710	221.740	221.770	221.800
16	221.830	221.860	221.890	221.920
17	221.950	221.980	222.010	222.040
18	222.070	222.100	222.130	222.160
19	222.190	222.220	222.250	222.280
20	222.310	222.340	222.370	222.400
21	222.430	222.460	222.490	222.520
22	222.550	222.580	222.610	222.640
23	222.670	222.700	222.730	222.760
24	222.790	222.820	222.850	222.880
25	222.910	222.940	222.970	223.000
26	223.030	223.060	223.090	223.120
27	223.150	223.180	223.210	223.240
28	223.270	223.300	223.330	223.360
29	223.390	223.420	223.450	223.480
30	223.510	223.540	223.570	223.600
31	223.630	223.660	223.690	223.720
32	223.750	223.780	223.810	223.840
33	223.870	223.900	223.930	223.960
34	223.990	224.020	224.050	224.080
35	224.110	224.140	224.170	224.200
36	224.230	224.260	224.290	224.320
37	224.350	224.380	224.410	224.440
38	224.470	224.500	224.530	224.560
39	224.590	224.620	224.650	224.680
40	224.710	224.740	224.770	224.800
41	224.830	224.860	224.890	224.920
42	224.950	224.980		

* Operation of the Quadrant System is in clockwise direction. (See Chart 1.)

Distribution:

OCD Regions, staff college, State and local CD Directors

Defense Coordinators of Other Federal Agencies
 Military Support Planning Officers

Before the
FEDERAL COMMUNICATIONS COMMISSION
Washington, D. C. 20554

FCC 73-407
96483

In the Matter of)	
)	
Inquiry into the provisions)	Docket No. 19723
of Subpart F, Radio Amateur)	RM-968, RM-1116,
Civil Emergency Service)	RM-1478, RM-2032
(RACES), in Part 97.)	

NOTICE OF INQUIRY

Adopted: April 18, 1973;

Released: April 20, 1973

By the Commission: Commissioners Robert E. Lee and H. Rex Lee absent.

1. In our Report and Order adopted today on Docket 17315, we denied a petition to expand the emission privileges for stations operating in the RACES program because of the expressed opposition to further expansion of privileges for RACES stations, among other reasons. Four other petitions for rule making have been filed requesting additional amendments to the provisions in Part 97, Subpart F, Radio Amateur Civil Emergency Service (RACES).

2. RM-968 was filed by the County of San Diego, and requests amendments permitting RACES stations to be operated by radio remote control through a control link utilizing non-amateur frequencies. Petitioner desires to use the microwave facilities of the Government Emergency Operators Centers for this purpose.

3. RM-1116 was filed by the California Disaster Office. The petition requests extensive rule changes to Subpart F, including expansion and revision of frequency allocation for RACES.

4. RM-1478 was filed by the Area "D" Civil Defense and Disaster Board, Pomona, California, and requests Section 97.193(a)(3) be amended to authorize 40F2 emission for radioteleprinter operation in the frequency bands 145.17-145.71 MHz, 146.79-147.33 MHz, and 220-225 MHz.

5. RM-2032 was filed by Murray Green, and requests amendments to rules to permit Technician Class licensees to operate in the 50.35-53.75 MHz, 145.17-145.71 MHz, and 220-225 MHz frequency bands in RACES. Petitioner also requests the frequencies 146-147 MHz be authorized for RACES with emissions 0.1A1, 1.1F1, 6A2, 6F2, 6A4, and 40F3.

6. As stated in Subpart F, RACES provides for amateur radio operation for civil defense purposes only, during periods of local, regional, or

national civil emergencies. It is a radiocommunication service carried on by licensed amateur radio stations while operating on specifically designated segments of the regularly allocated amateur frequency bands, under the direction of authorized local, regional or federal civil defense officials pursuant to an approved civil defense communications plan. Persons holding amateur radio operator licenses, and persons holding certain grades of commercial radio operator licenses are eligible to operate RACES stations provided they are enrolled in the Civil Defense organization as a radio operator.

7. Stations operating in RACES share the allocated frequencies with other amateur radio stations conducting non-RACES amateur radio-communication. Inasmuch as the privileges of amateur radio operator classes (Section 97.7), do not apply to the operation of RACES stations, except for some limitations for holders of the Novice Class and Technician Class, and since non-amateur operators may operate RACES stations, appropriate safeguards are necessary to insure that non-essential RACES radio-communication is not conducted at the expense of regular amateur radio-communications.

8. RM-968 is concerned with the control of RACES stations by radio remote control in one particular Emergency Operations Center, San Diego, California. Due to radio interference restrictions at that particular site, the frequencies 220-225 MHz available to RACES stations for remote control cannot be used. Petitioner proposed amendments to the Rules to permit Local Government (Operational Fixed) microwave equipment to be used for the control link.

9. RM-1478 states that the authorization of 40F2 emission in the frequency bands 145.17-145.71 MHz, 146.79-147.33 MHz, and 220-225 MHz for audio frequency-shift keying in radioteleprinting will "... materially benefit the RACES service by allowing the use of the superior characteristics of this mode, e.g., sensitivity, noise, interference and power ratios."

10. Petitions RM-1116 and RM-2032 request expanded and revised frequency allocations for RACES stations. RM-1116 does not offer any rationale for the extensive frequency and emission authorizations requested. Additionally, petitioner proposes rules changes relating to the organizational and operational phases of the RACES program. RM-2032 claims the potential value of Technician Class licensees to support the RACES program is lost by the prohibition against such licensees obtaining RACES station authorization for operation as members of RACES. Petitioner states that:

"... a large portion, if not the majority of today's FM repeater users, hold Technician Class licenses", and "... the utilization of FM VHF repeaters, together with mobile and portable communications equipment and dedicated Amateur

Radio operators, provides an enormous reserve of emergency communications in support of local civil defense operations."

11. These petitions, like the petition denied in Docket 17315, would expand the privileges for stations and operators in the RACES program. Since the same frequencies and emissions are common both to RACES activities and to other amateur radio activities, the allocation of additional privileges to RACES could have an impact upon non-RACES activities. In light of the lack of any positive response to the proposed amendments in Docket 17315, and because of the lack of any other substantive information on the general need in the RACES program for the proposed amendments, this Notice of Inquiry is intended to elicit comments and suggestions from informed persons and organizations familiar with RACES and the Amateur Radio Service.

12. In order to assist the Commission in making determinations in these areas, informed parties are requested to submit comments and suggestions relevant to the following:

- I. Is RACES an effective means of providing needed communication services during periods of local, regional, or national emergencies?
- II. Is the present licensing system for RACES stations appropriate? Should stations authorized to be operated in RACES be assigned distinctive call signs which could only be used for RACES activities?
- III. What abuses, if any, of the Rules by RACES stations are commonplace? What are possible solutions to ending these abuses?
- IV. Should additional or different privileges, e.g. frequencies, emissions, operators, be authorized for RACES stations? What are the most needed additional privileges? What are the consequences, to both RACES and the Amateur Radio Service in general, if RACES privileges are expanded? What are the consequences if RACES privileges are not expanded?
- V. What additional safeguards, if any, are required to insure that non-essential RACES radiocommunication is not conducted to the detriment of non-RACES amateur radiocommunication?

13. This action is taken pursuant to Sections 4(i), 303, and 403 of the Communications Act of 1934, as amended. Comments must be filed on or before July 1, 1973. All relevant and timely comments will be considered.

14. In accordance with provisions of Section 1.419 of the Rules, an original and fourteen (14) copies of all comments, suggestions, pleadings, briefs, or other documents shall be furnished the Commission. Responses will be available for public inspection during regular business hours in the Commission's Broadcast and Docket Reference Room at its Headquarters in Washington, D.C.

FEDERAL COMMUNICATIONS COMMISSION

Ben F. Waple
Secretary

ANNEXES - PART III

TYPICAL EMERGENCY COMMUNICATIONS PLANS
INVOLVING
THE AMATEUR RADIO SERVICE

Annex

- 14 - Amateur Radio in British Columbia Civil Defence
 - Owen Evans, VE7QT
- 15 - Manual of Peacetime Operations for Alberta EMO Amateur Radio Net
- 16 - The Use of Amateur Radio in the Saskatchewan EMO Communications Plan
 - Bill Parker, VE5CU
- 17 - Extract from the Saskatoon EMO Communications Plan
 - Bill Parker, VE5CU
- 18 - A Model Plan for the Involvement of Amateurs in a Local Emergency Measures Organization (Kingston)
 - Art Blick, VE3AHU

AMATEUR RADIO IN BRITISH COLUMBIA CIVIL DEFENCE

This annex is an edited version of the correspondence and plans originated by Mr. Owen Evans, VE3QT, used in his successful efforts to integrate the Amateur Radio Service into British Columbia's emergency communications plans developed by Mr. Mike Considine, Communications Officer for the British Columbia Provincial Civil Defence.

2554 Shelbourne Street,
Victoria, British Columbia,
385-1386
October 22, 1971.

Dear Y.L. and O.M.

On being approached to act as liaison to the B. C. Civil Defence and assistant S.E.C. respectively by the B.C.A.R.A. and the S.C.M., I had decided to decline due to age and the thought that I had served Amateur Radio Organizations for long enough.

Then I met Mr. Mike Considine, the newly appointed Communications Co-ordinator for B. C. Civil Defence. His enthusiasm and desire to cooperate fully with us sparked me anew and I accepted these appointments. You will feel the same way when you have an eyeball with Mike. Until now I had never realized the many advantages available to Amateurs through B. C. Civil Defence.

I would like to go on with this letter by quoting from a statement by Dr. Daniel Linahan S.J. who was taking part in an "International Meeting on Earthquakes" conducted by the "NATO Committee on the Challenges to Modern Society." He stated in part "The ability to communicate from within the disaster area to outside sources of assistance is most important. All possible communications sources should be considered by governments when they are developing their emergency operating plans. In several past disasters Amateur radio operators have performed vital functions in the post disaster period. Therefore, I recommend that all countries foster the development of a national organization of Amateur radio operations and that this organization be trained to assume emergency communications functions if the need arises."

This statement very aptly expresses the aim of B. C. Civil Defence communications. They are now continually collecting information on the many and varied communications resources of the province with the object of having as many alternatives as possible available in the event of an emergency. They consider one of the most important of these is the Amateur radio organization.

In the past much has been said about this importance and indeed it has been recognized, but steps to truly evaluate the capability and organize it seem to have gone awry. Thus many misunderstandings and misconceptions have naturally arisen.

The ultimate, I am assured as far as Civil Defence is concerned is to have an organization of amateur radio operators set up and run by amateurs, providing an emergency controlled net which would cover the province to the

maximum extent possible. This arrangement should be run in such a fashion that while being available to serve its purpose, it should also contribute added interest to the hobby.

I would like you to note that they say organized and run by the amateurs. They now realize it is your hobby and in no way do they wish to even imply any interference with it. They merely want to solicit our help in setting up an operating system which could be set in motion should the need arise.

What sort of occasions would require my services, you might ask? B. C. is in the earthquake zone and so relate this to the Anchorage, Alaska earthquake where amateurs provided practically the only means of communications to the outside world. We are subjected to floods in many parts of the province and these often take out the common carriers. If you let your imagination go, many more possible situations will come to mind. Also don't forget that nuclear war is not impossible and any sane government must keep this eventuality in mind and be prepared for it. Can you imagine what a nuclear weapon, dropped on Vancouver, would do to the province's common carrier systems?

Your next question, if you have stuck with me thus far, is how am I to participate? The thought is to base the organization on the "9200 GMT 3755 net" which already exists, and organize around this.

It is very difficult to predict when and where emergencies will take place, and so it is equally difficult to say when and where amateur radio would be required. Consequently the organization must be very flexible. You may be away on holidays or at work and we recognize these limitations, so if we can line up an alternate so much the better.

If you are still in a questioning mood you might ask, "how am I to know that I am required on the net?" Arrangements are being made with the commercial broadcasters in the province to broadcast a message, should an emergency arise, alerting the net or some part of it. While you might not hear the broadcast, one of your friends probably would and the broadcast would request that you be informed.

It is all very well to set up an organization such as we have talked about above, but unless it is used it will wither and die from lack of interest. To foster this interest it is intended to set up interesting simulated emergency situations which will challenge the amateur radio participant and so keep him in touch and interested.

At this time we want to get some idea of how many amateurs would be willing to take part - after all you cannot plan such a thing as this until you know your resources. If you are, would you mind filling in the small form attached and send it back.

If you indicate you are interested you will hear again in due course when plans have been finalized.

73's

Owen Evans.
VE7QT

BRITISH COLUMBIA CIVIL DEFENCE

AMATEUR RADIO NET

It is important that first and foremost we should establish what the BC CD A.R.N. is and what it is not.

First, it is a function of the BC ARPSC which has been established to assist Civil Defence in emergencies. It has been formed to assist in conjunction with the A.R.E.C. and not to compete with it. The ideal objective which is being aimed at is suggested to be that all those who are A.R.E.C. participants would also be BC CD A.R.N. members and vice versa, thus providing a way of strengthening both nets.

You might say, "Why have two nets when A.R.E.C. should do?" Well, A.R.E.C. is set up and organized geographically to respond to emergency situations at the instigation of the amateurs themselves.

In the case of BC CD A.R.N., we find the Provincial Civil Defence Organization divides the Province into six zones which in no way matches the geographical arrangements of A.R.E.C. From the earliest days, Amateur Radio has endeavoured to help people in emergency situations and Civil Defence has exactly the same objective so, therefore, it is logical we should work together. To do this, we felt that we had to be able to re-orient our amateur emergency communications organization to be compatible with the Civil Defence one when emergency situations arise and thus be set up to work with them.

It is of interest that in the United States, as most of you no doubt know, the amateurs have an organization called Radio Amateur Civil Emergency Services, (R.A.C.E.S.) which is designed to perform the same sort of job for Civil Defence.

Although in their case, it is largely organized and controlled by Civil Defence, in our case we organize and control ourselves but meet Civil Defence needs by liaison with their people at the different levels, i.e., Provincial, Zone and Municipal.

It is worthy of note that we say organized and run by the Amateurs. Civil Defence realizes it is your hobby and in no way do they wish to even imply any interference with it. They merely want to solicit your help in setting up an operating system that could be set in motion should the need arise.

There is another point, disagreeable though it may be, which perhaps we should remember while we are talking about reasons for the Civil Defence net. If there ever was a war or even a serious threat of one, the Federal Government, as you know, would take all Amateurs off the air except those who are registered to provide emergency communications in such a situation. Later on in this paper, you will see how this is done but at the moment it is sufficient to say that by registering people in the Civil Defence net, we have a way of establishing who will be left on the air to carry out emergency communications. A special list of frequencies is assigned for this eventuality and would be used in conjunction with special communications. The frequency list is attached. The call signs for each individual are

being arranged with D.O.C. and, when received, a list of these will be added to this written description of our organization.

Having established reason for needing the Civil Defence Net, let us next look at the objective. It is to have an organization of Amateur Radio Operators set up and run by Amateurs to provide a controlled emergency net which would cover the Province to the maximum extent possible.

"What sort of actions would require my services?", you might ask. British Columbia is in the earthquake zone and so relate this to the Anchorage, Alaska earthquake where amateurs provided practically the only means of communications to the outside world. We are subject to floods in many parts of the Province and these often take out the common carriers. If you let your imagination go, many more possible situations would come to mind. Also, don't forget that nuclear war is not impossible, as we previously mentioned, and any sane Government must keep this eventuality in mind and be prepared for it. Can you imagine a nuclear weapon, dropped on Vancouver. What would it do to the Province's common carrier system?

It is very difficult to predict when and where an emergency will take place, and so it is equally difficult to see when and where Amateur Radio will be required. Consequently, the organization must be very flexible. In addition, we must remember that you may be away on holiday or at work and must realize this is another limitation which requires flexibility in the organization. Of course, this one can be overcome if you can have a backup for such a situation.

Now that we have some idea what we want to be able to achieve, let us next think how it is to be done.

Going along with the Civil Defence division of the Province into six zones, (~~see map attached~~), 1 - Victoria, 2 - Vancouver, 3 - Prince Rupert, 4 - Prince George, 5 - Nelson and 6 - Kamloops, we do the same. In each, an Amateur has accepted the job of co-ordinating the net activities in his zone with the Zone Civil Defence Co-ordinator. Their names, calls, addresses and telephone numbers are in the list which is attached.

Space has been left for the names, etc. of Deputies and one or more net controllers to be added as they are selected by the Zone Amateur Net Co-ordinator. It is obvious that people in these additional positions will be needed as one person cannot and should not be asked to do the whole thing himself.

This organization, you will see, has the flexibility needed and permits us to operate one Province-wide Net, or by individual zones as the need dictates. The general organizational set up already discussed is also illustrated by the diagram (Appendix I) attached. You will note that the lines of control of the organization are all on the amateur side of the house. As would be expected, the operating side, i.e., the handling of traffic for Civil Defence, is shown as a line directly between the net and the Civil Defence Authorities. In this way, we may help them to help others.

Now we come on to the point of alerting the net. This may be achieved in several ways. Arrangements have been made with the commercial broadcasting medium to transmit messages for Civil Defence in the event of an emergency so you may be informed in this way. On the other hand, you may get a telephone call from a Civil Defence Official, your Amateur Net Co-ordinator, or someone who has heard that the net is being alerted. Of course, if you hear of a situation developing which might require your help, it would be sensible to keep a broadcast receiver on your local station. A periodic check of the BC CD A.R.N. frequency would also be a good idea if you can do it.

Not too much need to be said in relation to procedure, as that which is usual to Amateurs will be used. However, perhaps one or two particular points are worthy of emphasis:

- a) Be brief on the air.
- b) Follow the instructions of your net control.
- (c) Be sure the message you are asked to transmit is authentic, as false messages may cause serious problems and confusions. It is vital that the message be transmitted exactly as received as misinterpretations may develop into the gravest situations. If you are in doubt, verify before transmitting.
- (d) Always make sure that there is a date, time and a number on any message that you transmit on either CW or phone. If there is a word count, this information should be included. The reason for this is the need to identify previous messages when it is necessary to refer to them and to ensure that the whole message has been received.

FREQUENCY ALLOCATION

<u>80 METRE</u>	<u>PRIMARY</u>	<u>SECONDARY</u>
1. ZONE NET CONTROL to PROVINCIAL NET CONTROL	3766 KHz	3790 KHz
2.		
a. VICTORIA ZONE (VIZ) NET	3778 KHz	3766 KHz
b. VANCOUVER ZONE (VAZ) NET	3772 KHz	3766 KHz
c. PRINCE RUPERT ZONE (PRZ) NET	3742 KHz	3766 KHz
d. PRINCE GEORGE ZONE (PGZ) NET	3748 KHz	3766 KHz
e. NELSON ZONE (NEZ) NET	3796 KHz	3766 KHz
f. KAMLOOPS ZONE (KAZ) NET	3760 KHz	3766 KHz
g. SPARE	3784 KHz	3766 KHz

Each pair of frequencies is assigned for use within individual zones. When the net or a part of it is activated set watch on the primary for your zone. The secondary is provided in case the primary is unusable. The spare is available to any zone should both primary and secondary be unusable.

3. 40 METRE

ZONE NET CONTROL to PROVINCIAL NET CONTROL	7150 KHz	7160 KHz
---	----------	----------

4. ZONE FREQUENCY	7190 KHz	7160 KHz
-------------------	----------	----------

For use by zone net control if necessary to contact stations unreachable on 80 Metres.

5. 20 METRE

At this time it is not considered that frequencies in this band are necessary. If subsequent events prove otherwise we will change our ideas.

2554 Shelbourne Street
VICTORIA, B C
September 20th, 1972

Dear V.L. and O.H.

Having sent you a set of notes on August 3rd on how our Civil Defence Amateur Radio Net should be organized and run I thought the next step should be to test it out with a simple check-in on Saturday morning, September 30th at about 10:00 A M (1700 GMT). It should take no more than an hour.

I have arranged with Mike Considine, Civil Defence, to have a short message sent via the Commercial Broadcasting Stations at the time mentioned above as a way of starting the ball rolling.

Each member of the Net is asked to:

1. Tune a broadcast receiver to the local radio station of your choice at about 9:30 A M (1630 GMT).
2. At about 10:00 A M set watch on your 80 Metre Zone net frequency.
3. When the Zone Net Controller calls the role, indicate whether or not you heard the alerting message on your local broadcast station. If you did, give him its identity. If you didn't, but subsequently did hear the message before the end of the test, call Net Control and tell him.

Net Controllers are requested to:

1. Check with the Provincial Net Controller on 80 metres as soon after the net is alerted and as traffic conditions permit. If no contact on 80 m. use 40 m. as specified.
2. During the exercise note the calls of those who check in and the information on broadcast stations heard.
3. Close your Net at approximately 10:30 or when you think you have all the check-ins you are going to get.
4. Pass the list of Net members who checked in, together with the broadcast information, to the Provincial Net Controller when he directs you. When completed, the Provincial Controller will close the net.

If possible, Zone Net Co-ordinators are requested to join the exercise as a Net member and subsequently put the Civil Defence Co-ordinator in the picture on how the exercise went off.

73's

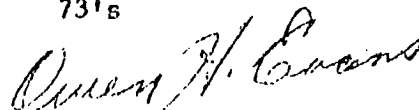

Owen Evans
VE7QT

ENCL.

P.S. If any other Amateurs join in, note the names and calls and we will see if they wish to join.

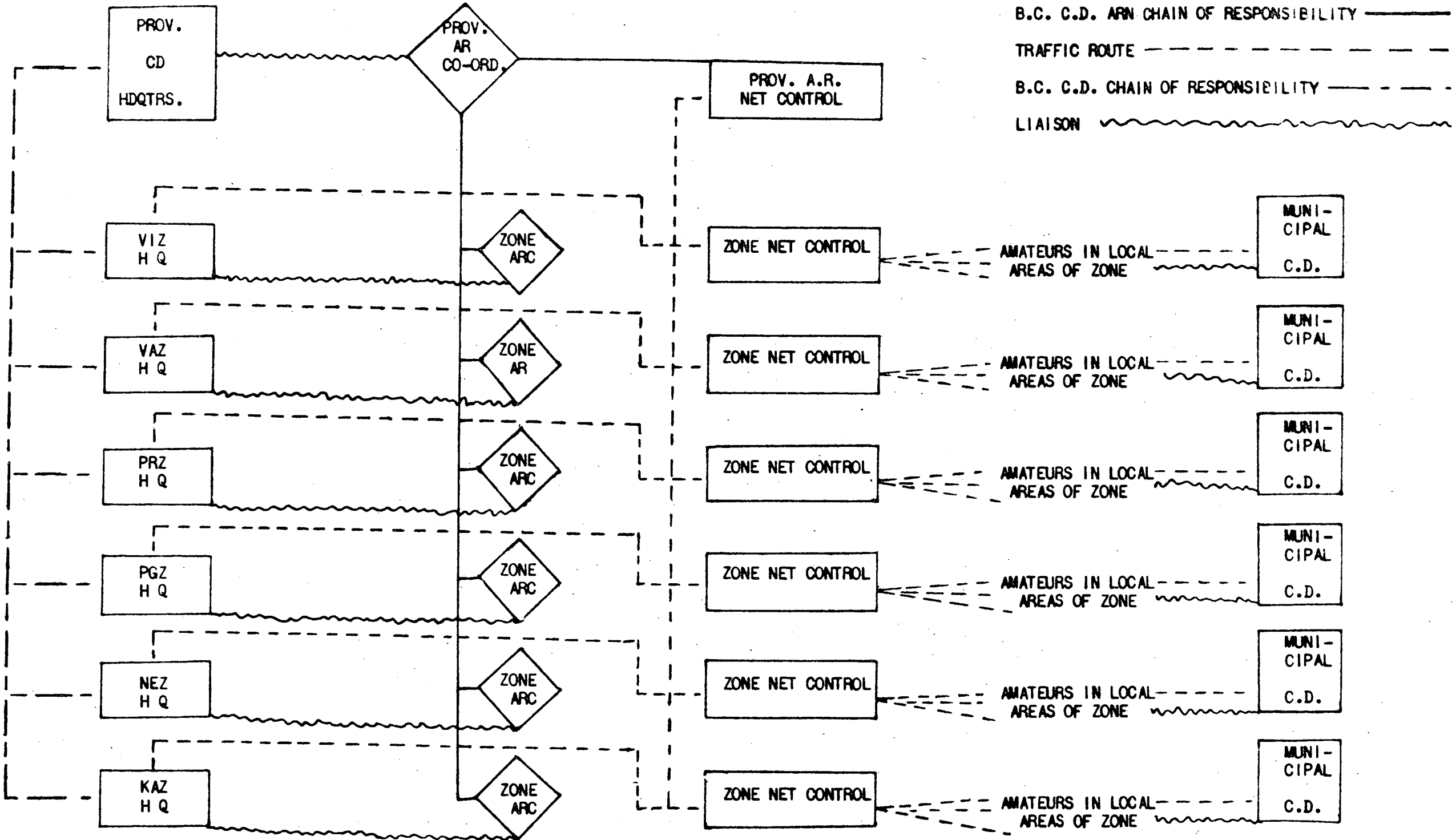

B.C. C.D. ARN CHAIN OF RESPONSIBILITY ———
TRAFFIC ROUTE - - - - -
B.C. C.D. CHAIN OF RESPONSIBILITY - - - - -
LIAISON ~~~~~

THE AMERICAN RADIO RELAY LEAGUE, INC.



OFFICE OF THE
SECTION EMERGENCY COÖRDINATOR

QST
OFFICIAL ORGAN

Box 2 RR # 1
Fort Saskatchewan, Alta.
TOB 1PO
5 March 1973.

Mr D. Burrill VE3GDC
151 Fanshaw Ave
Ottawa, Ontario
K2H 6C8

Dear Mr Burrill:

I am enclosing a copy of our Alberta Emergency Amateur Radio Network Peacetime Operations Manual which you requested from Mr W Vine at Arnprior recently. It is in the process of being updated to keep its usefullness - this is always a chore with something like this.

As Communications Officer for Alberta EMO I am always interested in other Ham activities outside the province. We have four section nets which are on the air each Sunday morning to handle test traffic and training. Emergency power plants are supplied to active members with suitable accommodation for same.

Should you care to drop me a note concerning EMO Hams in your locality or wish further info on our activities please use the above address.

My hamming is pretty well all done on 80 but do get on 20 once in a while so could hook up with you some time.

73

E Roy Ellis
E Roy Ellis VE6XC
Communications Officer

MANUAL OF PEACETIME OPERATIONS
FOR
ALBERTA EMERGENCY MEASURES
AMATEUR RADIO NET

PURPOSE OF THIS MANUAL

The main reason for this manual is to furnish the local Co-ordinators with a list of Alberta Emergency Measures Amateur Radio Operators who have volunteered their radio stations and their services for Peacetime Emergency Radio Communications.

Names and phone numbers of Co-ordinators and "Hams" (Amateur Radio Operators) are compiled here for ready reference.

It will be the responsibility of everyone concerned to notify E. Roy Ellis (VE6XC, Fort Saskatchewan) of any change in the information as listed. This, in turn, will be forwarded to the Supervisor - Industry Defence, Alberta Government Telephones in Edmonton for updating and re-issue.

The up-to-date lists will be issued when required and the local Co-ordinators advised of any changes in their area.

Additional information will be supplied in future manuals as required, such as Mobile Radios, Additional Operators, Emergency Power Generators, etc.

INSTRUCTIONS
- FOR -
ALBERTA EMERGENCY MEASURES AMATEUR RADIO NET
PEACETIME EMERGENCY OPERATIONS

In the event of an emergency in the area where there is no established communication system, or where an emergency has disrupted telephone service, the E. M. O. Co-ordinator in the isolated area should be aware of the situation.

If, through his knowledge and it is considered essential to establish communications outside the emergency area, the following will apply:

1. Contact an Amateur Radio Operator.
2. Have him establish communication with another Amateur inside or outside the isolated communication area as the case may be.
3. Attempt to contact Amateurs that are geographically located to ensure the fastest and most economical service.
4. All Amateurs, unless otherwise informed, should continue monitoring to provide assistance if requested.
6. Monitoring only should be conducted by Amateur's not involved in the actual communication link to ensure that essential messages are transmitted promptly.
7. Amateurs are to handle only the written or verbal messages that are authorized by the EMO Co-ordinator or the person in authority in the area.
8. Any Co-ordinator involved in a peacetime emergency in his area should keep informed as to the progress of the restoration of normal communications so as to be able to relieve the Amateurs of their duties at the earliest possible time.
9. Mr. E. R. Ellis, Section Emergency Co-ordinator, VE6XC will monitor from either the Emergency Measures Ham Station or his home station to assist in the operations as the need arises.
10. Expenses incurred by Amateurs in the performance of their voluntary duties during an emergency should be the responsibility of the Local Co-ordinator or Municipal Official in charge of the area involved in the emergency.

GENERAL

1. Restitution of authorized expenditures may be handled by the municipality or higher levels of government depending on what financial assistance is granted. The Amateurs are donating their time and the use of their personal equipment and should be reimbursed by the municipality by whatever means at the earliest possible date.
2. It is to be fully understood that the only expenses involved, would be the ones directly connected with the actual emergency.
3. It is estimated that emergency communications supplied by amateurs in this day of great technical advancement will be for a brief duration at the most. This makes the immediate alerting and establishment of an Emergency Measures Amateur communication network that much more essential if we are to supply that life line of radio communication in peacetime emergencies.

TELEPHONE DIRECTORY FOR -

ALBERTA EMERGENCY MEASURES AMATEUR RADIO OPERATORS AND CO-ORDINATORS

<u>LOCATION</u>	<u>CO-ORDINATOR</u>	<u>RADIO AMATEUR</u>	<u>RADIO CALL</u>	<u>RESIDENCE</u>	<u>BUSINESS</u>
BARONS	Mrs. June Cowie			757-3790	
		Mr. J. W. Row	VE6WZ		
BARRHEAD	Mr. J. H. Yuill			674-2862	2409
		Mrs. Elsie Thompson	VE6YW	674-2332	
		Mr. L. Beattie	VE6AKQ	674-3134	3119
BONNEYVILLE	Mr. R. Inman			826-3192	3479
		Mr. B. Barnes	VE6BB	826-3484	3366
CALGARY	Mr. M. Bernier			282-2744	265-6000
		Mr. D. A. Sutherland	VE6FK	277-1670	266-9220
		Mr. R. K. Massett	VE6AZU	266-5393	265-7110
		Mr. B. A. Payne	VE6OR	253-1056	261-3379
COALDALE	Mr. L. V. Scheibner			345-3450	328-3376
		(Co-ord & Amateur)	VE6AM		
CRAIGWYLE	Mr. W. J. O'Neill			665-2258	2264
		Mr. F. Applegate	VE6SS	665-2445	
DIDSBURY	Mr. L. Berscht			335-3102	3053
		Mr. A. Easton	VE6FC	335-3067	
DRAYTON VALLEY	Mr. F. J. Galvon			542-3218	3635
		Mr. H. T. Swanlund	VE6HS	542-3727	3311
DRUMHELLER	Mr. F. J. Porter			823-2195	2235
		Mr. R. C. Jungling	VE6HB	823-9677	
		Mr. J. Fitzpatrick	VE6LI	823-2667	
EDMONTON	Mr. Wm. B. Brown			489-4888	489-0642
	Mr. E. L. Lenox			454-4450	425-3804
		Mr. E. Roy Ellis	VE6SCD	543-4362	469-2869
FALHER	Mr. B. R. St. Pierre			837-2410	2221
		Mr. M.J.E. Duguay	VE6AJQ	925-2312	837-2439

<u>LOCATION</u>	<u>CO-ORDINATOR</u>	<u>RADIO AMATEUR</u>	<u>RADIO CALL</u>	<u>RESIDENCE</u>	<u>BUSINESS</u>
FORECAST	Mr. V. Arnold	Mr. H. Garber	VE6GZ	867-3801	3530
		Mr. D. Karl	VE6AJF	867-2253	
		Mr. C. Luca	VE6ASL	867-2155	
				867-2245	
FT. SMITH, N.W.T.		Mr. N.A. Sturko	VE8	872-2150	2349
FT. SASKATCHEWAN	Mr. Stan Walker	Mr. E. Roy Ellis	VE6XC	543-3462	6341
				543-4362	469-2859
GLENEWOOD	Mr. W. M. Bohne	Mr. S. J. Read	VE6SR	626-3258	
				626-3257	
GRANDE PRAIRIE	Mr. N. Trepanier	Mr. W. F. Wood	VE6RL	532-7320	4471
		Mr. E. W. Smith	VE6NM	532-5667	
				532-4848	2324 ext.65
GRIMSHAW	Mr. H. Perdiger	Mr. Lorne Ingrey	VE6AWI	332-4172	4474
				332-4423	
HANNA	Mr. J. Shack	(Co-ord & Amateur)	VE6AHV	854-3426	3113
		Mr. J. Phibbs	VE6OT	854-2364	
		Mr. Eugene Kush	VE6ASK	854-3452	3361
HINKS CREEK	Mr. W. M. Nash	Mr. I. W. Hoover	VE6II	934-3963	
INNISFAIL	Mr. Wm. Perrott	Mr. E. K. Johnson	VE6UK	227-3431	3788
				227-5159	
LA CRETE		Mr. S. B. Nafziger	VE6HW	928-2331	2331
LETHBRIDGE	Mr. W. Falconer	Mr. S. B. Kent	VE6BM	328-5177	2341
				328-4825	
MEDICINE HAT	Mr. J. L. Carswell	Mr. A. C. Hill	VE6YE	526-3175	5971
				527-1370	526-3998
MILK RIVER		Mr. T. Myagawa	VE6VE	647-3856	3557
NANTON	Mr. W. Murray	Mr. H. M. Read	VE6AVV	486-2596	2064
				486-5564	5564
OLDS	Mr. C. Oxtoby	Mr. G. C. Christopherson	VE6CC	226-3580	3311
				226-2148	335-3321

<u>LOCATION</u>	<u>CO-ORDINATOR</u>	<u>RADIO AMATEUR</u>	<u>RADIO CALL</u>	<u>RESIDENCE</u>	<u>BUSINESS</u>
OYEN	Mr. A. R. Johnston	Mr. N. W. Evans	VE6UA	664-3669 664-2424	3740
PINCHER CREEK	Mr. A. Ames	Mr. D. W. Hembling	VE6ABX	627-3531 627-3918	3262 3925
PROVOST	Mr. Harry Hobbs	Mr. W. Watson Mr. J. S. Stewart	VE6WW VE6CD	753-2001 753-6574	2368
RED DEER	Mr. W. M. Olgivie	Mr. E. S. Hall	VE6PZ	346-6808 346-3868	5050 5556, Loc.67
ST. ALBERT	Mr. R. A. Russel	Dr. Duncan M. Proudlock	VE6AD	599-8274 599-3976	429-6629 422-1087
SPIRIT RIVER	Mr. Fred H. Leeks	(Co-ord & Amateur) Mr. E. W. Donison	VE6AKK VE6EC	864-3947 864-3669	3597 3860
STETTIN	Mr. P. J. Bailey	Mr. A. R. Johnston	VE6WJ	742-2539 742-3067	
TOMAHAWK	Mr. F. J. Galvon (Drayton Valley)	Mr. H. R. Gilbert	VE6ZM	542-3218 339-3950	3635
VIKING	Mr. Bert Hill	Mr. Fred Rademacher	VE6AEN	336-3338 336-4926	3410 3215
WESTASKININ	Mr. C. Hoyle	Mr. R. Cotterill	VE6KP	352-4286 352-3057	2400 2295
WILWOOD	Mr. Albert Cooley	Mr. J. F. Newbery	VE6QN	325-2283 325-2311	3787

Fort Smith, N.W.T.
VE8

ALBERTA EMERGENCY PLANNING AMATEUR RADIO LIST

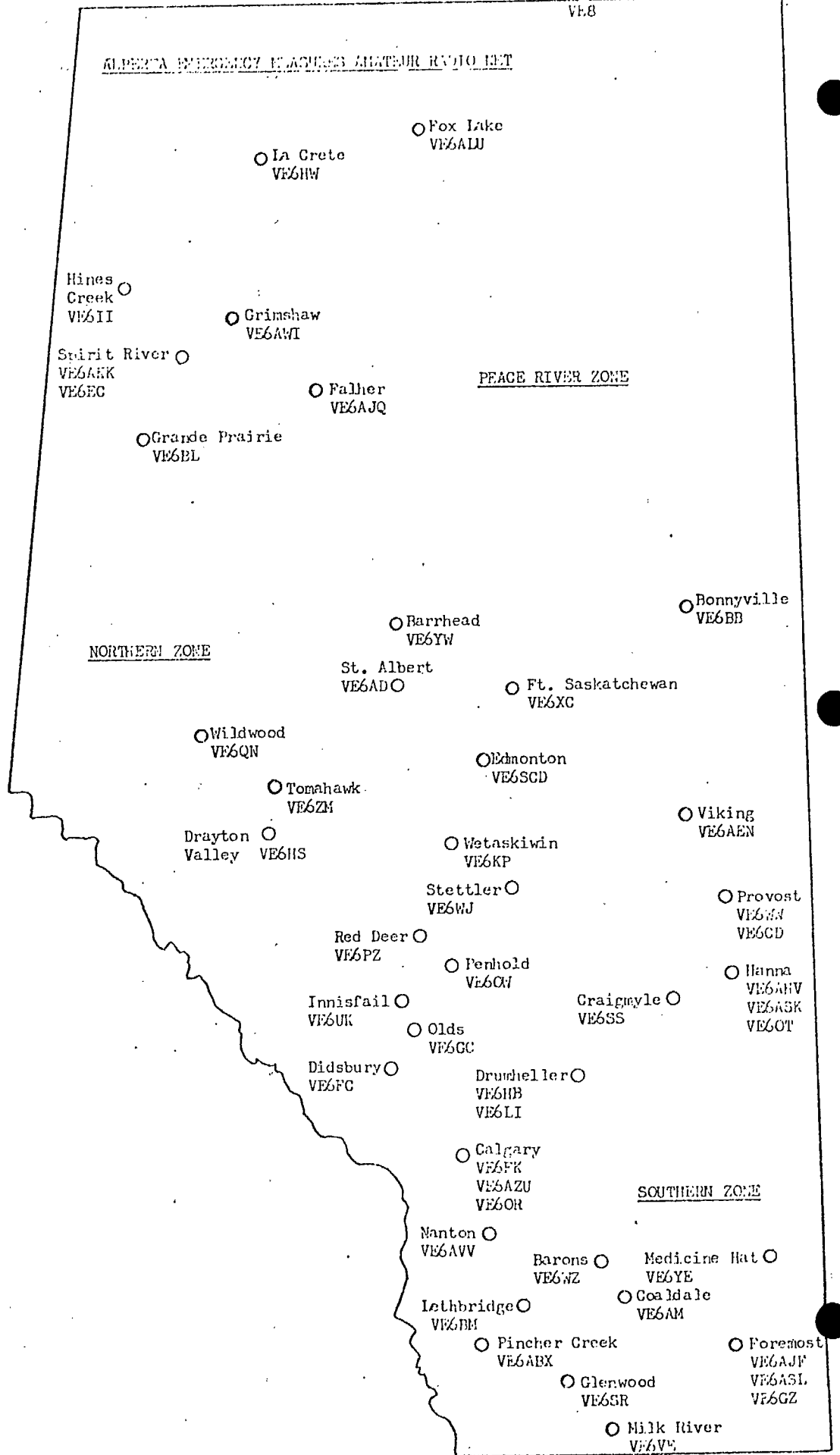

SASKATCHEWAN AMATEUR RADIO EMERGENCY COMMUNICATIONS

W. H. Parker, VE5CU, Asst. Director, Saskatoon EMO

In the province of Saskatchewan, Emergency Amateur Radio Communications is guided by the Amateur Radio Emergency Corp. At the present time, the Co-ordinating Officers are as follows:

Saskatchewan Emergency Co-ordinator (SEC)

W. H. Parker VE5CU

District No. 1 Emergency Co-ordinator (EC)

Al Davies VE5AQ

EC for District No. 2

Lionel Coderre VE5QO of Regina

EC for District No. 3

Bob Ediger VE5RJ of Saskatoon

EC for Prince Albert

Barry Ogden VE5B0

The four districts in which Saskatchewan has been divided for Emergency Amateur Communications relates to the 11 districts in which Saskatchewan E.M.O. has divided the province.

It is the responsibility of each Emergency Co-ordinator in each of the four districts to become familiar with the E.M.O. Director or Co-ordinator in his area and to organize the amateurs in their districts to become members of AREC. Because of the scarcity of amateurs in some smaller areas this appears to be the overall answer to supply communications to E.M.O.

In the eleven districts in which E.M.O. operates, we have a good distribution of radio amateur operators. These operators are kept in the state of readiness by means of a provincial net which meets every Sunday at 9:30, Central Standard Time. The purpose of this net is to keep all members informed as to what is happening in terms of recent bulletins or information regarding Emergency Communications.

In total, the province of Saskatchewan has some 360 operators who belong to the Amateur Emergency Radio Corps. This is well over half of the total number of hams licensed in the province. The SEC has the responsibility of working closely with the provincial branch of E.M.O. through the Director, Mr. Jim Eaton.

At the present time, the newly formed Emergency Measures Communications Group of the City of Saskatoon has developed a plan which will be used as a guide to the rest of the province. The objective is to meet the needs of Saskatchewan E.M.O. at Provincial, Municipal, or rural areas. This overall system has been in operation for 9½ years and has been very efficient in a number of emergencies that have taken place within that time.

It is to be noted that this plan is as simple as possible and yet very effective. It is the very simplicity of the plan which allows it to be a very efficient backup system to Saskatchewan E.M.O. In reality, the AREC is looked upon as a backup communications system, but is prepared to operate in the full should the need arise.

The equipment available from the above-mentioned amateurs in different districts of the province make such communications feasible. A further breakdown of control personnel is seen in each district from 1 - 4. Each EC has appointed from 1 - 4 Assistant EC's, which in most cases, live in some other part of his area and are therefore in touch with the E.M.O. Co-ordinator in their area. The benefits of this system are such that it allows a small area to be activated, or the entire province as the case may be.

Extract from
SASKATOON EMERGENCY

MEASURES ORGANIZATION (EMO)

EMERGENCY COMMUNICATIONS PLAN

AIM

The aim of this *plan* is to provide a comprehensive communication system to ensure adequate and secure communications between the emergency government headquarters (E.O.C.) and all emergency services during an emergency period.

The plan outlines basic communications requirements and the operational procedures and systems necessary to meet these requirements.

INTRODUCTION

During a National or Civil Emergency period, emergency municipal government headquarters will be established at the E.M.O. Headquarters. Present communications systems will be operational from the E.O.C. to provide Department Chiefs with complete contact with their field organizations. Municipal systems will be used for Police, Fire, Engineering, Public Works, (Water, Electrical, Sewers) and Transportation Services. Amateur Radio and General Radio Service Systems will be used for Winter Search and Rescue, Radcf, and Health, and Municipal backup. Other commercial systems are also incorporated into the overall plan but their use to date has been limited.

ORGANIZATION

The Chief of Communications is a member of the Planning Committee and is appointed by the Chief City Commissioner (Director of Saskatoon E.M.O.). There are two Communication Officers each having separate but closely co-ordinated duties. The organizational chart is as shown in the Appendix.

EMERGENCY COMMUNICATIONS REQUIREMENTS

The requirements for communications under emergency conditions are as follows:

1. Contact between members of the Planning Committee at the E.O.C. and their respective field organizations.
2. Radio networks for each of the field organizations.
3. Contact between Saskatoon and Provincial E.O.C.
4. Message Control and Courier System within the E.O.C.

EXISTING COMMUNICATIONS

1. Police

The Police radio network operates on two frequencies. Traffic and Patrol Divisions use 155.19 Mhz and Criminal Investigation Divisions use 155.73 Mhz. All C.I.D. vehicles are equipped with two frequency radios, as are some traffic and patrol vehicles. The E.O.C. is equipped to operate on 155.19 Mhz (F1), leaving 155.73 Mhz free for other Police Department business not directly involving the E.O.C. The base stations have standby power facilities.

EXISTING COMMUNICATIONS - Cont'd

2. Fire

The Fire Department network operates on 153.83 Mhz. A base station is provided at the E.O.C. The base stations have standby power facilities.

3. Engineering, Public Works, Utilities

The Engineering Department network operates on 169.05 Mhz. It includes Public Works (operations) and Environment (pollution) installations and mobiles. A base station is provided at the E.O.C. The Engineering Department has as well as the main dispatch centre an emergency trouble centre which has control by means of remote operation and leased telephone lines of the radio systems operated by the utilities, namely the Electrical Department 169.59 Mhz and the Waterworks, Parks, and Recreation Departments 166.95 Mhz. These base stations do not have permanent standby power facilities, however portable generators are readily available. The E.O.C. Unit has emergency power.

4. Transit

The Transit system consists of a small system operating on 170.25 Mhz. It will be useful at marshalling locations for the dispatching of transport units. The base station is not equipped with standby power facilities.

5. Private Commercial Systems

The major private commercial radio systems as those operated by United Taxi, Radio Cab, Towing Companies, and several construction companies. These systems are not directly accessible to E.M.O. however all can be contacted by telephone for specific assignments.

EXISTING COMMUNICATIONS - Cont'd

6. Ambulances

The two ambulance companies each operate a V.H.F. radio system. Neither company is equipped for operation on the common D.O.C. frequency reserved for ambulances.

7. Hospitals

The three main hospitals have established a radio network using portable radio equipment operated by amateurs on 145.32 Mhz. These sets are all battery operated and can also operate on the other amateur frequencies in this band if necessary. This equipment is provided by Saskatoon E.M.O.

8. Search and Rescue

The Search and Rescue organization is using general radio service (27.80 Mhz) in conjunction with the Saskatoon Snowmobile Club. The E.M.O. Communications Van is used as the co-ordinating centre and has available VE5-EMO Mobile if required on 2 meter. The Chief of Search and Rescue also has access to the Fire Department system (153.83 Mhz). These teams at present are used for winter search and rescue.

9. Radef

A General Radio Service System is presently being set up for RADEF communications between reporting stations and the E.O.C. The Chief of R.A.D.E.F. also has access to the Engineering Radio System (169.05 Mhz).

10. St. John Ambulance

The St. John Ambulance have a Snowmobile and are part of the Search and Rescue Team. They also have a completely equipped

EXISTING COMMUNICATIONS - Cont'd

10. St. John Ambulance - Cont'd

First Aid trailer. They are presently negotiating with the idea of becoming part of the G.R.S. Network during exercises and emergencies.

11. Provincial EMO Headquarters - Regina

The primary communications link between Regina and Saskatoon is via telephone. The back-up is via amateur radio using S.S.B. and teletype. A V.H.F. repeater link is also being planned and could be used on voice or teletype.

12. Amateur Radio

The amateur radio system is provided by the members of the Saskatoon Amateur Radio Club (VE5AA). They are comprised of base stations and mobiles. In a large scale emergency, however, it is a possibility that commercial power may be out and many of the base stations will therefore be inoperable. The mobile systems operating on 80M SSB and VHF. FM are therefore the ones expected to be available. The present amateur repeater is not equipped with standby power and would therefore be out of commission during a power failure.

13. General Radio Service

The General Radio Service System is provided by two very active clubs, the Saskatoon General Radio Club and The React Club. These stations are composed of base and mobiles. Most base station equipment has provision for operation directly from a 12 volt battery. Most sets in use at the present time are capable of operation on 23 channels. This can allow for several simultaneous

EXISTING COMMUNICATIONS - Cont'd

13. General Radio Service - Cont'd

operations to take place. Several of the channels are subject to interference from other areas of Canada and the United States. The primary frequency to be used for E.M.O. is 27.80 Mhz which is outside the standard G.R.S. channels and therefore less susceptible to interference. It is assigned strictly for emergency use by E.M.O. and to units approved by D.O.C. for Business Band only.

14. Emergency Operating Centre

Within the E.O.C. is a Communication Centre.

Provision is made for 8 operating positions:

1. Police - V.H.F.
2. Fire - V.H.F.
3. Engineering - V.H.F.
4. Radef - G.R.S.
5. E.M.O. - G.R.S.
6. Amateur - V.H.F.
7. Amateur - H.F.
8. Amateur - T.T.Y.

Saskatoon E.M.O. is presently licenced as VE5-EMO amateur and XM34-3495 G.R.S. After April 1, 1973 licences will be issued for Business Band operation with additional call signs assigned for base and mobiles. It is proposed to use 6 channel mobiles and have them equipped with channels 4, 9, 11, 19, and 27.80 Mhz.

Low powered transmitters and receivers will be used for the

EXISTING COMMUNICATIONS - Cont'd

14. Emergency Operating Centre - Cont'd

Municipal Frequencies. All traffic will be monitored however all direct instructions will go through the specific operations centres.

The E.O.C. is equipped with standby power so that the entire operation is independent from outside influences.

Message Control also operates out of the communications centre.

15. E.O.C. (Mobile)

The Saskatoon EMO has a Volkswagon Van which is equipped with a P.A. System, Amateur and G.R.S. Radio equipment. The unit is power supplied by a trailer mounted generator to supply 117 volts A.C. At present all radio equipment is operated from 117 volts.

16. Boy Scouts of Canada

The Boy Scouts will be used as couriers within the E.O.C. They will handle all traffic between the Communications room and the Planning Area to keep members of the Planning Committee up to date on requirements and status of their field organizations.

17. Manpower

Regular courses are being conducted for the training of personnel as radio operators and message writers. Upon graduation of the Communications Course they will be trained to qualify for the D.O.C. Restricted Radiotelephone Operators Certificate.

To become a member of the Saskatoon Emergency Communications Division a minimum of a R.R.O. Certificate is required. Complete Telephone Fanout system has been prepared and becomes a part of this plan.

EXISTING COMMUNICATIONS - Cont'd

18. Additional Communications Requirements

There are still some additional communications systems required to complete the Saskatoon E.M.O. Communication Plan.

1. Amateur Radio V.H.F. repeater link between Regina and Saskatoon.
2. Use of common ambulance frequency for large scale emergencies by both Saskatoon companies.
3. Provision of standby power for the present amateur radio V.H.F. repeater.
4. Integration of Saskatchewan Emergency Measures Air Division (SEMAD) into the system.
5. Provision of permanent 12 volt D.C. power supply for the E.M.O. Van.
6. Updating of control trunking and priority restoration for emergency telephone systems.

19. Diagrams & Charts

Forming part of the Saskatoon Emergency Communications Plan are the following Charts and Diagrams:

1. Emergency Communications Operations March, 1973
2. Communications Officers Radio Lines March, 1973
3. Communications Organization (Division) March, 1973
4. Planning Committee Organization January, 1973
5. Plan of Communications Operations Centre March, 1973
6. Telephone Fanout March, 1973
7. Telephone Control Trunking and Priority Restoration

Ian Brand, P. Eng.,
Chief of Communications
March, 1973

EMERGENCY COMMUNICATIONS DIAGRAMS

Introduction

1. This annex sets out a standard method of representing emergency communication systems for use by federal, provincial and municipal communications planners, which:
 - a. will show both existing and planned facilities in relation to the emergency organization to be served;
 - b. will be suitable for use on both block diagrams and maps or charts.
2. The symbols and procedures that follow have been discussed and agreed with provincial and municipal emergency communications officers and with the Army. They should be used, wherever possible, so that diagrams, supporting emergency communications plans may be presented in a standardized form.

Symbols

3. Basic:



Military Unit (establishment or building)



Civilian Unit (establishment or building)



Operational Vehicle (mobile)

4. Mobility:



Ground



Water



Air

5. Agency or Function Designators:

A

Amateur

AMB

Ambulance

CT









County

CD







Civil Defence

E	Emergency
EMO	Emergency Measures Organization
m	Engineer
*	Fire Service
F	Forestry
G	Government
HQ	Headquarters
+	Health (medical)
H	Highways Department
L	Linison
M	Mobile(s)
MR	Mobile Reserve
M	Municipal
PC	Police
P	Provincial
P	Public Utilities
PW	Public Works

-11-

	Radiological Defence
	Reconnaissance
	Rescue
	Regional
	Sub-Area, Sector, Sub-Division
	Taxi
	Traffic Control
	Welfare
	Zone

6. Technical:

	Radio monitoring unit (receiver only)
	Remote control unit
	Repeater (automatic)
	Switchboard or exchange
	Telephone
	Teleprinter
	Two way radio (all types)

- AM Amplitude modulated
- CW Continuous waves (code station)
- FM Frequency modulated
- RL Relay station (manual)
- RTT Radioteletype
- RX Receive
- SSB Single sideband
- TX Transmit
- W Watts

7. Circuits:

a. Basic:

- Landline (existing)
- - - - - Landline (planned)
- ~~~~~ Radio (existing)
- - - - - Radio (planned)

b. Landline Variations:

- engineered —————
- - - - - private - - - - -
- > to exchange

etc.

SASKATOON EMERGENCY MEASURES ORGANIZATION COMMUNICATIONS OPERATIONS

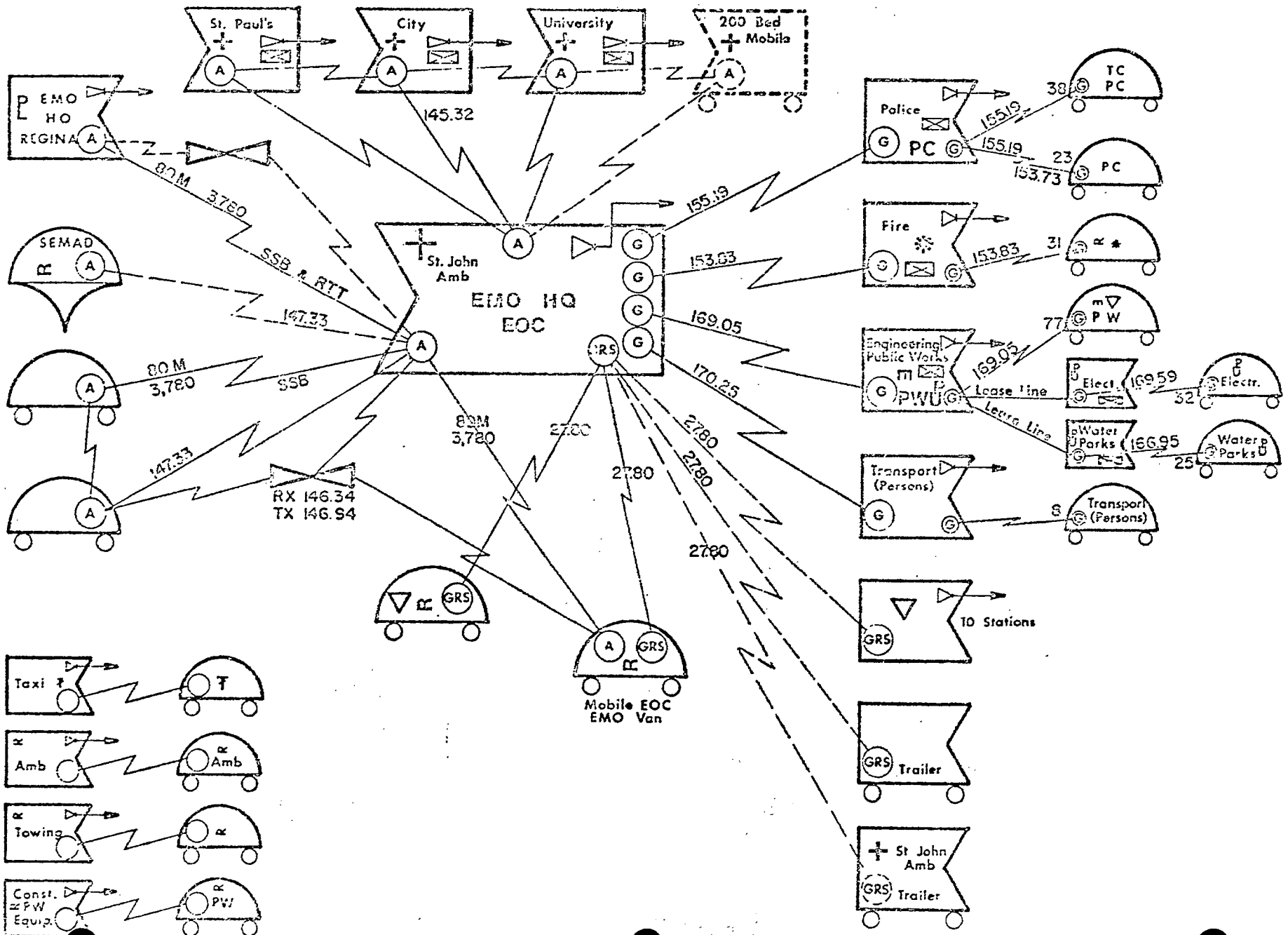

-13-

SASKATOON EMERGENCY MEASURES ORGANIZATION COMMUNICATIONS OFFICERS' RADIO LINKS

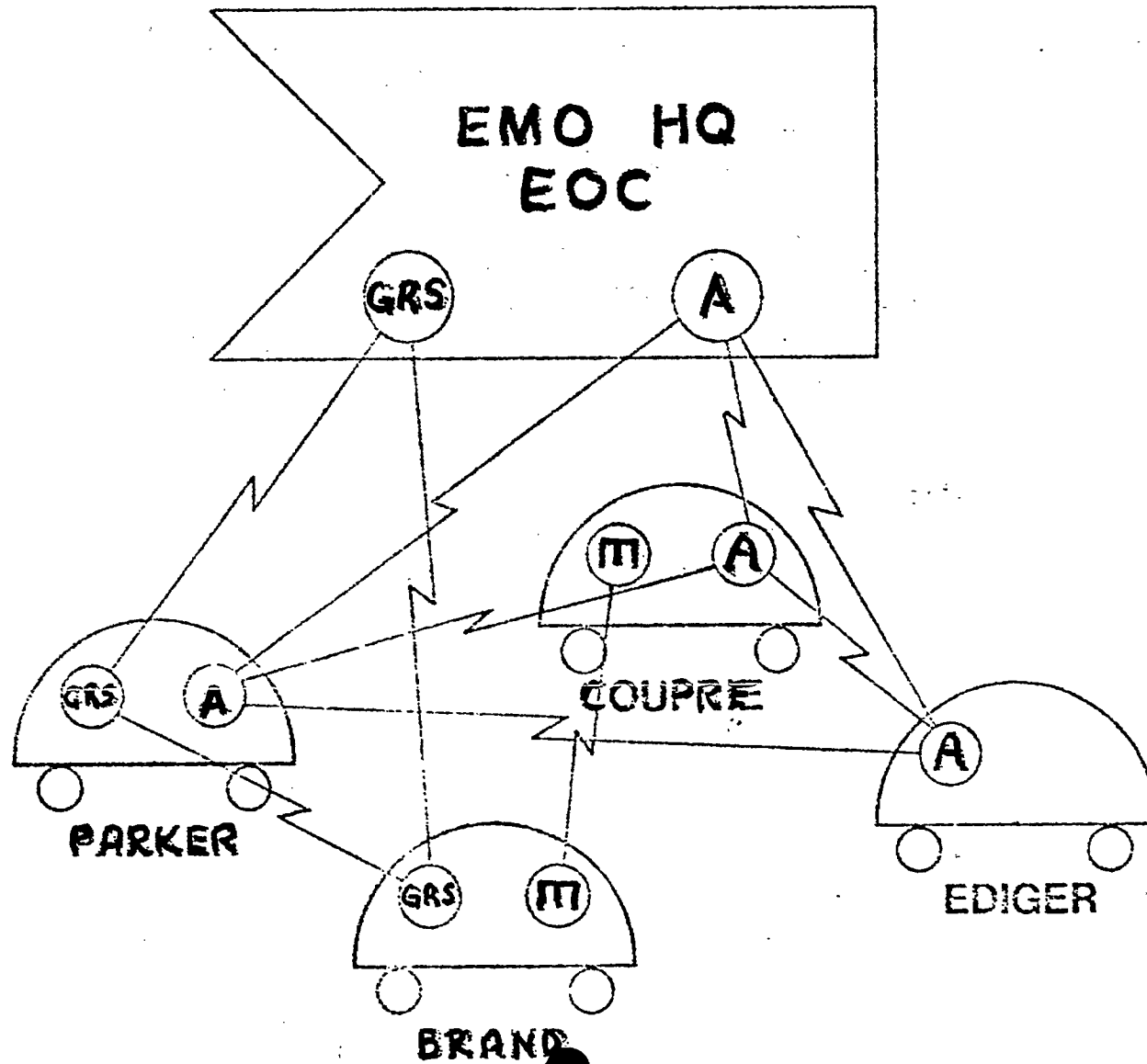

March 1970

SASKATOON EMERGENCY MEASURES ORGANIZATION COMMUNICATIONS DIVISION

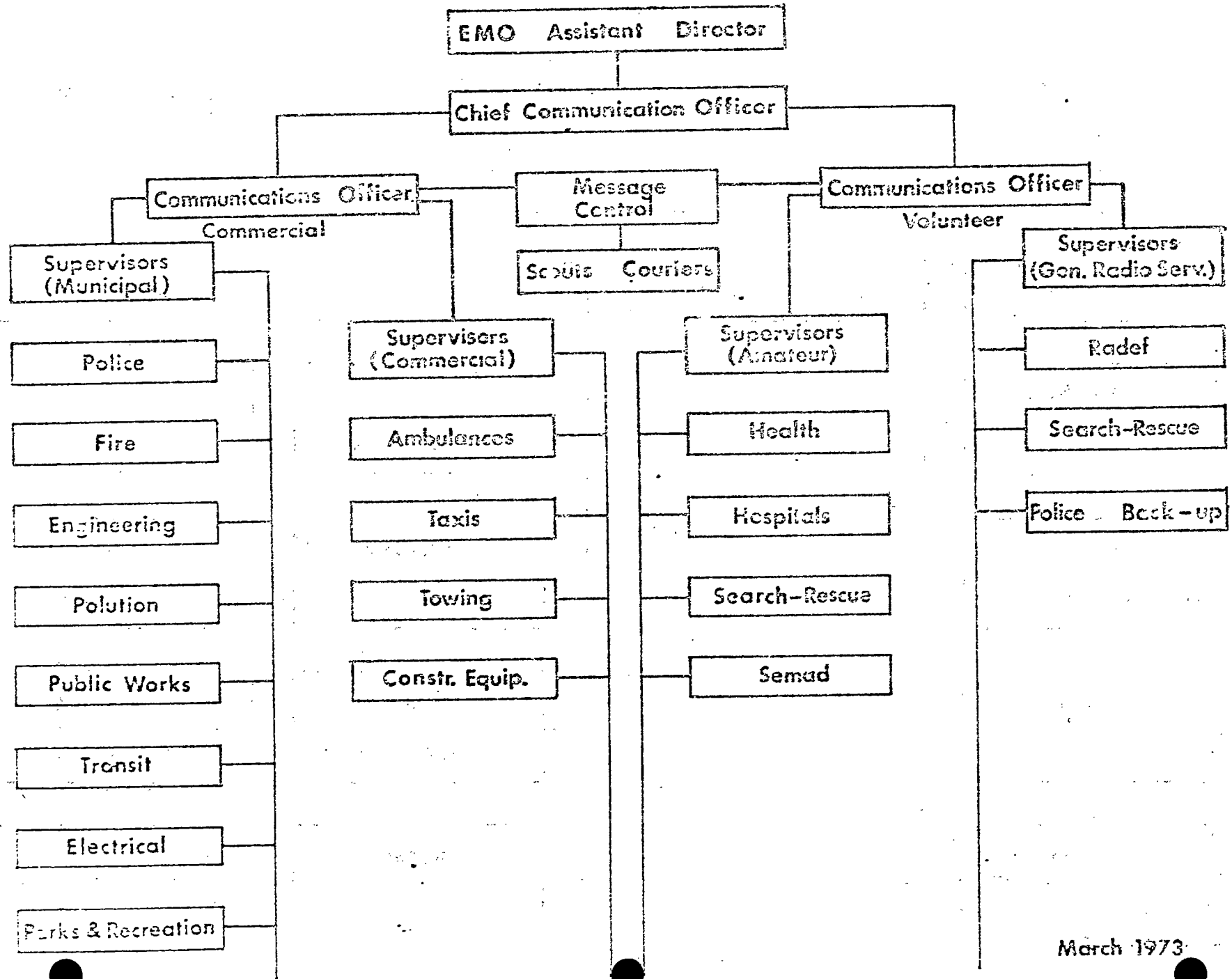

March 1973

Planning Committee

Saskatoon Emergency Measures Organization

January, 1973

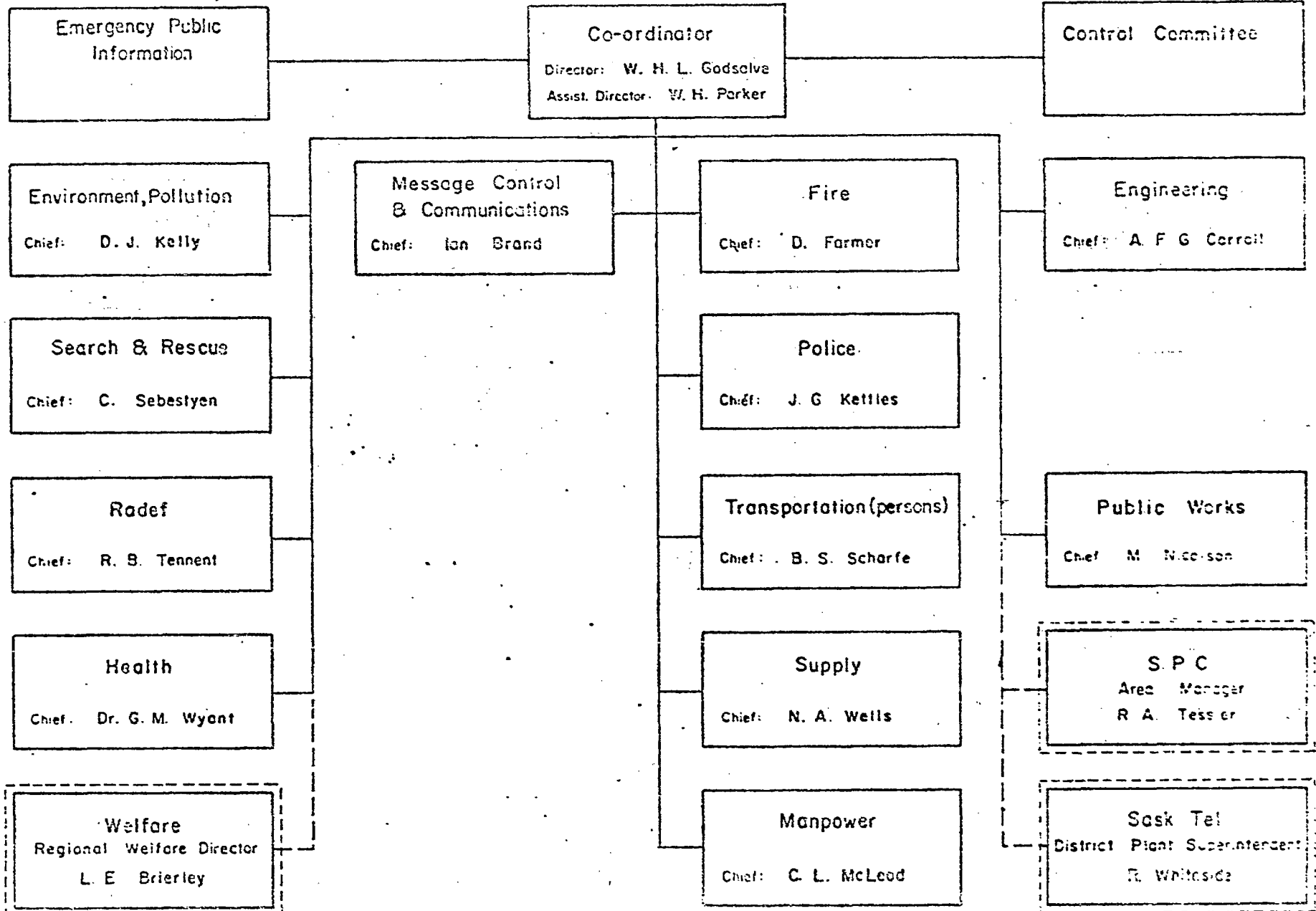

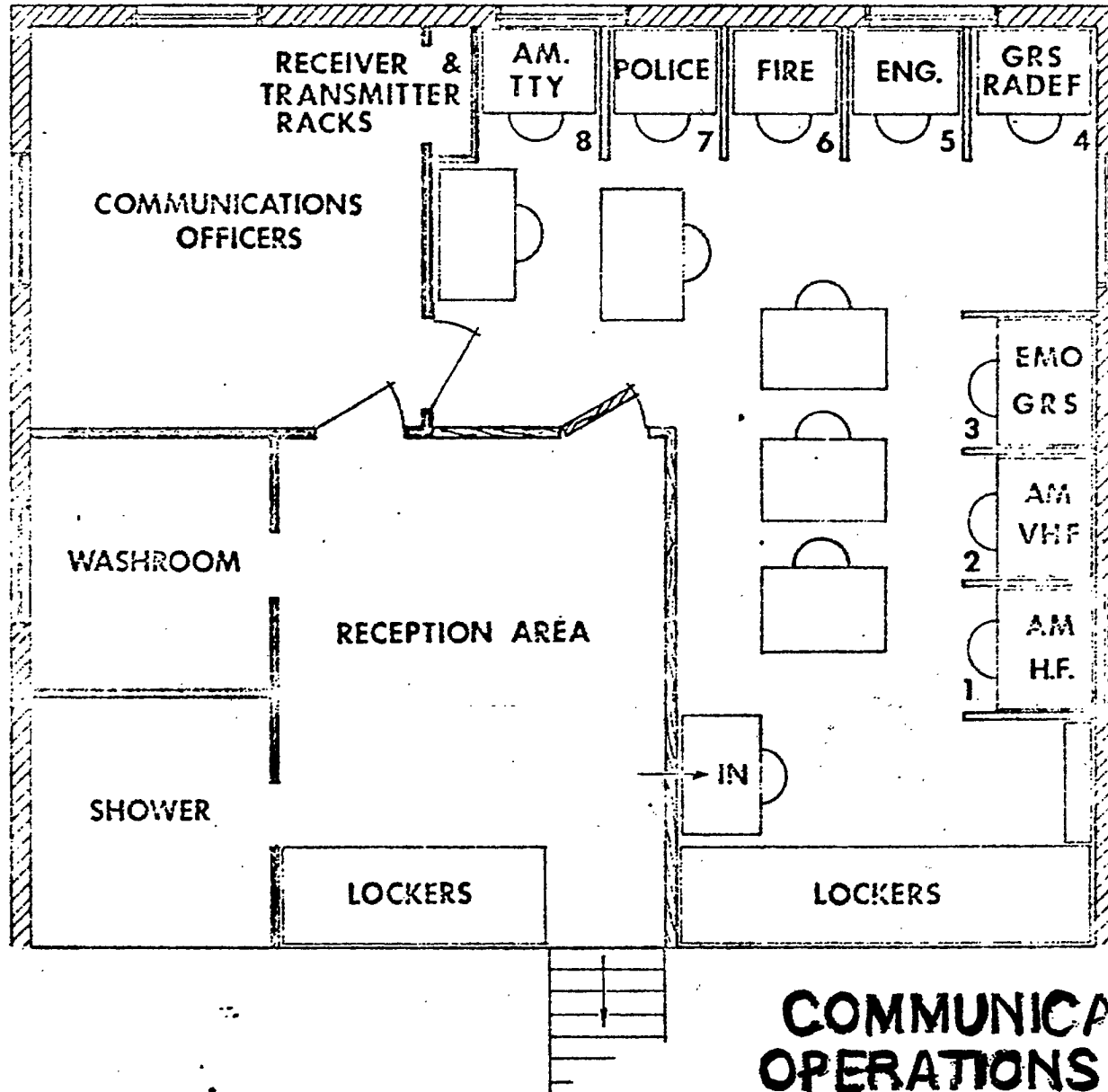

COMMUNICATIONS OPERATIONS ROOM

MARCH 1973

EMERGENCY COMMUNICATIONS PLANNING OFFICERS' CONFERENCE

CEMO COLLEGE, Arnprior, Ont., - February 6 - 8, 1973

A MODEL PLAN FOR THE INVOLVEMENT OF AMATEURS IN A LOCAL EMERGENCY MEASURES

ORGANIZATION

A. E. Blick - VE3 AHU - Communications Officer, Kingston/Frontenac EMO

It is possible that the EMO Communications Officers have not fully realized the assistance that the local amateur radio clubs can give to the establishment, maintenance and support of a local EMO communications system. I refer to the communications expertise of the radio amateurs, their capability to check out radio systems and their ability to improvise solutions to communications problems.

My talk this morning will detail how the Kingston Amateur Radio Club assisted the EMO Co-ordinator of Frontenac County in the planning, installing and support of the Kingston/Frontenac communications system.

When it was first planned to put in a VHF radio system for emergency communication throughout the county, the Chief Radio Inspector in the Field Office of the Department of Communications, Mr. Buster Doubleday, acted in an advisory capacity and was instrumental in having a Communications Officer appointed from the membership of the KARC.

Members of the club performed tests from locations selected in the county using Amateur two metre equipment and, on the basis of the results obtained, final decisions were made on the height of antennas, gain of antennas and polarization of propagation. At the request of the Co-ordinator, the club, in May, 1964, submitted a proposal to check the transceivers as received, check the installation of towers and antennas, install the transceivers and carry out a preventative maintenance program on a regularly scheduled basis. This request resulted in a formal contract being given to the club.

Additional contracts were let by the City of Kingston for the supply of antennas, towers, feed line cable and other accessories. When the contractor reported that the tower, antenna, etc., were installed, tests were made on the link between Cataraqui and Kingston, a distance of roughly six air miles. The transceivers used were Hammarlund Outercoms, and antennas specified were 10 element YAGI's, matched for coax cable feed, designed for operation on 149.5 MHz and installed on 40 foot towers. Tests made were disappointing with minimal signal strengths each way. A check found that the towers had not been properly based, were not grounded, had not been properly attached to the buildings and that there was no matching between the coax cable and the input to the antenna and the antennas supplied were for operation on TV channel 7 frequency 174-184 MHz.

This resulted in a further contract being issued to the club for the complete installation of the system with the club responsible for sub-contracting where necessary, and the entire system was installed in this manner.

The complete system is now installed. There is a "Southern group" working into Kingston and a "Northern group" working into Parham, located about 30 miles north of the city. This split is made necessary because of the difficult terrain encountered. Frontenac County is traversed by several ridges of relatively high hills running west to east while communications are required in a generally north to south direction. These hills seriously interfere with the propagation of VHF signals.

Our calculations showed that minimal signals were to be expected from the northern county stations to Kingston but stations were installed at Sharbot Lake and Cloyne with antennas directed at Kingston and tests made over a period of some weeks. Signals were certainly not satisfactory for dependable communications and the decision was made to split the system into two groups with Parham as the sub-control. Parham was selected as tests showed that good signals would result from all the northern group to this location and because the Parham station was operated in conjunction with the area ambulance service and operators were available 24 hours a day.

The entire system 'stands by' on our channel 1 - 149.525 MHz - with the northern stations concerned switching to channel 2 - 149.495 MHz - to pass traffic. Parham is equipped with antennas pointing north and south with a manual coax switch selecting the antenna for use. There is sufficient strength of signal received from Kingston base when using the north antenna so that Parham station is normally connected to that antenna and only switches to the south antenna to handle traffic from base Kingston.

I will mention that, due to our close proximity to the U.S. border, special permission had to be obtained from the DOC to use the high effective radiated power necessary for communications on several links. Many hours were spent by some of the club members in filling out the DOC forms, preparing profile maps and making the necessary calculations to substantiate the request for use of higher ERP.

Last year several of the operators of the northern group stations asked if they could be supplied with some sort of a portable antenna to assist them in supplying communications for search and rescue work in that area. The problem was that a township radio set could readily be transported to the control centre of these operations, power could be supplied from the emergency portable 1500 watt generators supplied to each station, but tests using whip antennas on a vehicle had not proven satisfactory. Members of the club purchased two TV channel 6 antennas, 5 element YAGI type with folding elements, dismantled the elements and designed and built two 4 element YAGI's for optimum operation on 149.5 MHz.

Swaged tubing for TV masts was also purchased and cut down to 5 foot lengths for easy transporting and each antenna supplied with four mast sections and a 50 foot length of coax cable with connectors. Tests were made in the area and it was found that the normal range from a base station to a vehicle antenna is 10 - 12 miles but with a portable antenna the range increased to 15 - 25 miles. Five of these portable antennas have now been made with three held in the northern group and two at EMO base in Kingston.

In the communications plan for the area, the Kingston Amateur Radio Club is committed to supply communications personnel for the organization, administration and control of communications in the emergency headquarters and to supply operators and equipment for communication links to various medical and welfare centres around the city. A two metre base station is installed in the communications centre and this can be used for direct communication to the portable/mobile stations at the centres or, through the two amateur repeaters serving the area - VE3 KER and VE3 KBR - to amateurs outside the city area who can relay traffic via HF or VHF facilities to as wide an area as desired.

I mentioned earlier that the amateurs can assist in the planning, installing and support of the communication system. Planning a system consists of much more than the selection of suitable sites for stations and method and means of communicating between these sites. The equipment used must be suitably housed, operators must be trained in its use and the base must be suitably equipped to operate as a communications centre serving several networks. In most centres amateur operators can be found who can assist in or carry out all of these tasks.

In Kingston, the emergency headquarters is located in the basement of the Frontenac County Courthouse, a rather historic building. The EMO communications tower which is mounted on the building holds the antennas used by various service departments, etc., in an emergency. These antennas are fed through two junction switch boxes manufactured by the club to give greater flexibility for operation.

The communications centre has several semi-sound-proofed operating booths along three of its sides in the office space normally used as the EMO office. These operating positions have been assigned to the EMO

provincial system the EMO county system and the Kingston Amateur Radio Club (KARC). The rest will be used, as necessary, by other systems including the police and fire departments, the public utilities and taxi companies.

Additional telephone facilities have also been installed in addition to the normal local used by the EMO office and the room is readily converted to a fully-equipped communications centre. The centre is off the main EMO conference room where the heads or representatives of government and services will be located in the emergency situation. Other areas in the basement are used for the storage of food, supplies and to house an emergency power plant.

The amateurs, through their annual participation in formal nets and in the annual ARRL Field Day exercise have a knowledge of the need for organization and administration of a communications centre and will be able to effectively run the centre if the need arises.

Support of the system includes the training of amateurs and township and city personnel to the level of Restricted Radio Operator and several classes have been held in and around Kingston over the years, with operating exercises for practice in the use of the equipment and system and handling of traffic. This has not been done specifically by the club but by the Communications and Assistant Communications Officers who are members of the club. At the moment the club has a membership of approximately 30 amateurs and over 20 of these have the RRO qualification.

Support also includes the checking and maintenance of the equipment used and this is done by the club by semi-annual inspections and repair where necessary. Caution must be applied in the repair of the transmitting equipment to ensure that it is repaired to specifications as the equipment is type-approved by DOC and cannot be modified, as amateurs may do to their own equipment.

This briefly outlines how a local club can work within the framework of the EMO. I realize that local communications systems have already been installed in most areas and are operating without amateur involvement and little can be done to now bring in the amateurs in these capacities. However, as has been demonstrated in many local emergency situations, there is a great need for communication expertise and the additional communications facilities that can be supplied by the amateurs.

There can, however, be limitations to the participation of amateurs in emergency operations. In May, 1967, a full disaster exercise was held in Kingston. This simulated the complete loss of communications in the Hotel Dieu Hospital, a major fire and the necessity to evacuate patients (simulated by Queens University students) to other hospitals in the area.

This exercise took place at 8:00 p.m. and the KARC supplied handie-talkies for communications within the building and portable and mobile stations for the control of evacuation. The exercise went very smoothly but, in the conference that came later, I pointed out that the average amateur worked for a living and, if the disaster took place between 8:00 a.m. and 5:00 p.m. on a weekday, it could be difficult to enlist enough amateurs to supply communications. Plans were therefore drawn up for local taxi firms to supply the control communications in the event the KARC could not do so.

As a postscript - in early November of that year disaster struck the Hotel Dieu Hospital, a major fire broke out in the basement of one wing, all communications went out and the entire wing had to be evacuated. The headline in the paper read, "WITH TRAGEDY NEAR AT HAND. COURAGE AND PLANNING PAID OFF." As it happened, the fire occurred around 8:00 a.m., the EMO Co-ordinator was on holidays outside the area and the amateurs were not involved. But the plans had been made and a major tragedy was averted.

In local and area disasters two types of communications are involved. One is what could be called "operational communications" and is that concerned with the administration and organization of the forces and services used. The other could be called "personal communications" and is that necessary to handle the traffic engendered by friends and relatives trying to contact people in the disaster area. This latter type of traffic can very quickly overload communications facilities and this is where the amateurs can and do give tremendous service.

In the Lively/Sudbury emergency, the local amateurs were first used to supply communications within the area for operations and, as other communication facilities became available, the amateurs took over the handling of personal traffic thus keeping the other communications facilities into the area open for operational traffic.

Amateur involvement in disaster communications has been more of a "catch-as-catch-can" arrangement and, reading over reports of amateur participation, one can see that some kind of co-ordinating plan is necessary for more efficient operation. Mr. Belleville has mentioned this in his talk on the Managua disaster and I again bring it to your attention.

Mr. Burrill has given a short run-down of the organization and administration of the Canadian Amateur Experimental Service -- the individual, the local club, the provincial society and the national Federation. All can play a role in assisting the EMO in the communications field. The individual by active participation in communications; the local club by assisting the county or municipal Co-ordinator; the provincial society by liaison with the provincial EMO Communications Officer; and the national Federation by over-all co-ordination and administration.

With the exception of British Columbia and Alberta,* not enough has been done along these lines, except on a local level. The Federation and the provincial societies are ready and willing to put their facilities at the disposal of Emergency Measures Organizations to hold discussions and talks and come up with plans for more participation by the amateurs in emergencies working under the control of the EMO and to form a viable communication system geared to the needs of these Organizations.

* At the time of writing, the author was not aware of the inclusion of Amateurs in the Saskatchewan emergency communications plans (Editor)

ANNEXES - PART IV

RECENT USE OF THE AMATEUR EXPERIMENTAL SERVICE
IN EMERGENCY COMMUNICATIONS

Annex

- 19 - Communications Service Provided to the Emergency Measures Organization During the 1973 St-John River Flood
- F. Ryder, VE1AIL
- 20 - A Report on Amateur Participation in the St-John River Flood, May 1973
- Lorne Titus, VE1IN
- 21 - "The Managua Earthquake"
- Ron Belleville, VE3AUM
- 22 - "Operation Crash" - Saskatoon Plan for a Hospital Disaster Exercise
- Bill Parker, VE5CU

COMMUNICATIONS SERVICE PROVIDED BY
THE AMATEUR EXPERIMENTAL SERVICE
TO THE EMERGENCY MEASURES ORGANIZATION
DURING THE 1973 ST. JOHN RIVER FLOOD

F.H. Ryder
B.Sc, M.Eng., P.Eng.
(M) IEEE, C.Eng., FIEE

May 8, 1973
Fredericton, N.B.

EMO Director Expresses Thanks To Many

Sir: Through this column⁴ I express on behalf of the New Brunswick Emergency Measures Organization our gratitude and appreciation to the many, many organizations and volunteer groups that contributed so significantly and responsively to the call to undertake the many and varied emergency activities that were required in this, the worst flood disaster to strike New Brunswick.

The fact that no deaths or serious injury were directly attributed to the disaster is indicative of the effective roles played by all concerned.

During emergency activities the role of some organizations may have inadvertently been overlooked. This would be unforgivable as the role of each group was so important and integral to the overall success of the operation.

The Fredericton Area Ministerial Association, represented by Dean Cooper, the Salvation Army, represented by Major Hornbrook, and members of the Saint John Ambulance Association were assigned the responsibility for establishing relocation centers for evacuees from the flooded areas and the success of their appeal is hereby recognized. Appreciation is expressed to the University of New Brunswick, Base Gagetown, the church organizations, the service clubs and private citizens of this area for their immediate response. Over 1,050 places were secured within a 1½ hour period.

The role of the staff of CFNB, CBZ, CIFSJ, the Amateur Ham Operators Association, the Citizens Band Group, the communications network of the Department of Natural Resources, the Department of Highways and the New Brunswick Electric Power Commission were, along

with the daily newspapers of the Province, powerful instruments in the establishment of an effective communications network.

The New Brunswick Emergency Measures Organization recognizes, with appreciation, the roles played by the following organizations and volunteer groups and is hopeful that the specific roles of each will be documented and fully recognized in the near future:

The Department of National Defence, Base Gagetown, the office of the Regional Director of Canada EMO, the Premier's office, the Federal and Provincial Departments of Agriculture, the Provincial Department of Highways, Natural Resources, Health, Social Services, Provincial Secretary, Fisheries and Environment, Municipal Affairs, Education, Justice, Supply and Services and Youth.

The RCMP, the RCMP Auxiliary, the Fredericton City Police and Fredericton City Hall.

The generosity of the NBEPC through the General Manager and Senior staff in providing the facilities of the fourth floor of the Commission Building to the N.B. Emergency Measures Organization and the information on river flows and projected levels provided by their Flood Forecast Center were instrumental in establishing communications with the public and keeping the public advised of the changing conditions as they occurred as well as allowing the N.B. Emergency Measures Organization to activate immediate and urgent emergency plans to meet the impending disaster.

The installation of emergency telephone service by the N.B. Telephone Co. Ltd., instantly on request, permit-

ted N.B. EMO to establish an emergency telephone number that was easily identifiable to the public.

The New Brunswick Emergency Measures Organization recognizes and deeply appreciates the spontaneous response of the public sector to the appeals for volunteers with power boats, with private cars for heavy equipment and for trucks and trailer trucks.

Special recognition is extended to the large number of teenagers and young adults who were instrumental in preserving valuable public documents, records and valuable books at the Legislative Library and York County Regional Library and for the role they performed in helping to sandbag and protect vital installations in and about the flooded area.

Appreciation is extended to McDonalds, to A and W, to the Salvation Army, to the Red Cross, the NBEPC cafeteria staff and to many Church and Service Clubs for their generous contributions in supplying food at their own expense to the many hundreds of people working in the operations center, the field operations and to the hundreds of people who were forced to evacuate their homes.

Recognition and appreciation is extended to Atlas Construction Co. Ltd., J. D. Irving Ltd., Diamond Construction Ltd. and the Department of National Defence for the provision of barges, tugs and other heavy equipment required for the evacuation of families and livestock.

Gratitude is extended to the many citizens of this area who opened their doors to provide food, lodging and comfort to the hundreds of people forced to evacuate their homes be-

FREDERICTON
CLEANER
MAY 14/73

cause of record high river levels.

To the many private citizens who volunteered their assistance at the operations center, the New Brunswick Emergency Measures Organization is warmly appreciative.

The emergency operation was a tremendous and vast undertaking and proved its effectiveness, largely due to the response of individuals, groups and associations from the private sector and the roles played by the depart-

ments and agencies of the Federal and Provincial Governments.

On behalf of the New Brunswick Emergency Measures Organization, I thank you wholeheartedly, Mr. Editor, for the opportunity to recognize and to express in this column our appreciation for the spontaneous response to the call for assistance during this emergency.

Henry V. Irwin
Director Emergency Measures Organization

Ham Radio Operators Team Up With Armed Forces

By ROGER ALAIN
Staff Writer

Volunteers can win many battles which might be lost by paid staff, but when you put the two side by side, the results can be astounding.

Amateur radio operators are teamed up with Armed Forces personnel in the battle against the St. John River, determined to maintain lines of communications so anyone requiring assistance can get it with the least possible delay.

Ron Hesler of Sackville was one of about 10 or 11 amateur radio operators working with the army yesterday, in rescuing people and livestock from farms and homes in the Maugerville-Sheffield area.

Mr. Hesler said he picked up a call for assistance off the radio network which he was monitoring at his home Sunday morning, and by 9 a.m., he and a friend from Moncton, Reid Park, were rounding up communications equipment from other club members in the area.

There were no walkie talkies in the Fredericton area, said Mr. Hesler, so the two men brought about five with them. As well, there were approximately five mobile car radio operators from the province who offered their services.

Three clubs were represented during yesterday's opera-

tions, including the Fredericton Amateur Radio Club, the Loyalist City Amateur Radio Club from Saint John, and the Maritime VHF Association from the Moncton-Sackville region.

When he and Mr. Park decided to come to Fredericton to assist, they found they would have to detour through Saint John. The additional 160 miles they had to drive didn't dampen their spirits.

Radio operations at the Burton communications centre are directed from the Emergency Measures Organization co-ordinating centre in the NBEPIC head office in Fredericton. An EMO officer is also attached to the signal group, operating from a base in the Burton Courthouse.

The value of the communications network was proved twice Sunday, when two military barges encountered problems. One vessel got both its propellers tangled in barbed wire. After a radio message was received at the base, a second barge was sent to the rescue.

The second incident resulted when the motor on another barge stalled, and the vessel was grounded. Again, a rescue vessel was dispatched, to safely retrieve the first one.

"Without a radio," said

Mr. Hesler, "there would be no way of knowing" a vessel was in trouble. The radios are also used to direct the barges in their search and rescue operations.

A number of shallow-draft barges are available, but not enough to do the job with ease. Mr. Hesler said a scow is expected from Irving Oil in Saint John, but it hadn't arrived by late morning, possible due to the strong down-river currents.

"The main problem is there aren't enough shallow draft vehicles to rescue the livestock," said the amateur radio operator.

That may be a problem with the rescue operations, but there is another problem waiting for him at home. He said he just returned from the States on the weekend, when he decided to come to Fredericton.

His wife wasn't too keen on the idea of losing him again, but she told him it was "something you have to do."

And that has been the name of the game during the St. John River flood, when hundreds of volunteers turned out for various jobs.

It was something they had to do.

COMMUNICATIONS SERVICES PROVIDED BY
THE AMATEUR EXPERIMENTAL SERVICES
TO THE EMERGENCY MEASURES ORGANIZATION
DURING THE 1973 ST. JOHN RIVER FLOOD
NEW BRUNSWICK - CANADA

The purpose of this report is to review the course of events of the 1973 St. John River flood and to describe the services provided by Radio Amateurs in support of EMO.

Reference is made herein to a report by the author entitled "Emergency Communications and the Amateur Experimental Service in New Brunswick, dated 12 February, 1973". This document was prepared as a talking paper to define the services which New Brunswick amateurs could provide the Emergency Measures Organization in the event of a civil emergency and for which service authorization is made by the Radio Act and the regulations thereunder.

The services actually provided by the radio amateurs in this emergency was in fact generally as described in the 12th February report and the technical deficiencies denoted therein were evident.

- a) Interference in the 80 meter band due to crowded multiple use.
- b) The limitation of the VHF system because of the lack of point to point repeater links.

The Sequence of Events

Saturday evening, the author, employed by N. B. Power as Director of Planning, on visiting the flood forecasting task group was present at the initial briefing of the Emergency Measures Organization Staff by the task group of the impending flood.

During the subsequent organization meeting the author was given the opportunity to define the communications capability of the Amateur Experimental service, and was authorized to proceed in implementing an amateur

communications system within the limits of the existing amateurs technical capability, as defined in the 12th February report.

The Wet Net

The matter was reviewed with Mr. Leo Doucet, co-ordinator between EMO and the New Brunswick Amateur Radio Association who unfortunately could not himself be present and within one hour an "HF Net", i.e. a continuous communication operation was initiated on 3750 in the 80 meter band. At the same time a VHF communication capability was also placed at the disposal of the EMO organization giving reliable VHF communications coverage of the area from Mactaquac to Jemseg.

The wet net on 3750 KHz was conducted by VE1TC with alternates VE1BM and VE1ACA who assured continuous operation.

The function of this operation was to receive reports on the water status and other impending problems throughout the region and to relay them to EMO headquarters. Advice was often quickly returned to the initiator of the message. Examples include:

1. Information on the Hartland Pumping station failure.
2. Arranged water supply and logistics for Hartland Blood Donor Clinic.
3. Reported on the flood situation in the St. Stephen area.
4. Reported on the flood situation in outlying St. John area.
5. Passed regular reports to Mr. J. Stuart Brooks, Power Commission Chairman, while at his home.
6. Arranged police escort for an ambulance Chipman to Fredericton.

A second function was to obtain equipment and operators for the VHF operation and this entire task was expeditiously and effectively dealt with.

The wet net was closed down at 11:19 on Wednesday, May 2 and re-opened at 8:35 on May 4 to provide communications between EMO Central and EMO Saint John by means of an 80/2 meter relay. Telephone communications to the latter office having become overloaded.

The VHF Operation in Maugerville - Sheffield

The Emergency Measures Organization Staff decided that the amateurs VHF services should be used in assisting EMO to co-ordinate the efforts of the Forestry Department, The Department of Agriculture and the Military in the rescue operations in the Maugerville - Sheffield areas.

Accordingly, the following communications services were provided.

1. Communications for a helicopter patrol of the area. The patrolman could provide first hand reports to the planners of the rescue operation.
2. Communications for a truck patrol which examined in closer detail the critical areas, and again first hand reports were provided to the planners of the rescue operation.
3. Established a communications link between the Burton control sub-centre and EMO headquarters.
4. Provided communications between the Burton sub-centre and each of the rescue skows.

This operation continued till Wednesday at 10:00 a.m. at which time EMO advised that supplemental communications were no longer required; they wished to rely completely on the military. The service was discontinued and by noon equipment had been dismantled and removed.

Mr. Leo Doucet was responsible for the equipment and staffing of all station and the author provided equipment and co-ordination of the amateurs effort at EMO headquarters.

It is to be noted that the Burton station as well as all of the stations on the barges were equipped and one half staffed by volunteers from St. John, Moncton, Sackville and Truro, N. S.; and the enthusiasm and skill which they applied to their effort was evidence in the competence displayed.

Equipment Availability

Of the some 30 Pieces of equipment in service in the operation only 4 pieces were modern transistorized equipment. The remainder, including the automatic repeater were at least 15 year old tube type equipment, four pieces

of which failed in service, and were replaced. The repeater as well was unservicable for two hours during which time repairs were made.

It is to be noted that the repeater has auxillary generation and all other units were capable of battery supply so that dependence on commercial electricity was not critical. VE1GT is the only repeater in the province with such auxillary power supply.

The Saint John Operation

With the possibility of flooding in the Saint John area a similar alert was placed in effect Tuesday evening, and remained operational till 4:00 p.m. Thursday.

A communications relay on the previously mentioned net of 3750 KHz in the 80 meter band was established utilizing the telephone for communication with EMO Saint John.

It was eventually discovered that telephone circuits became overloaded, and a VHF station was established at EMO Saint John.

Because of the lack of a regional VHF communications capability, Section 5 of the authors 12th February report, first hand radio communications with the Saint John staff was not possible, and the lack of this becomes evident in the problems which arose.

The Darlings Island Expedition

On Thursday, conflicting reports were received on the status of the residents and their animals on Darlings Island. EMO Headquarters requested reconaissance of the island by a party of amateurs and a report was in due course present to EMO officials.

Staffing

The names of the volunteers and the disposition of them is as follows. Fortunately all needs were not simultaneously required and therefore, people were re-assigned from one task to the other. Those assigned to Maugerville Sheffield task, not local residents were obviously required to travel to Oromocto to perform their duties.

(List omitted due to space limitations. Ed.)

Conclusion

To re-iterate, the lack of regional VHF communications capability played a considerable part in the frustration of direct first hand reports to EMO officials.

While the amateurs in Southern New Brunswick will attempt to overcome this difficulty, regulations made under the Radio Act required that such regional links be made at 220 MHz or higher. Equipment for 220 MHz is not available, except brand new, the same problem exists in respect of the necessary tone control equipment. I do not foresee the speedy elimination of this problem within our present capabilities.

A REPORT ON AMATEUR PARTICIPATION
IN THE ST. JOHN RIVER FLOODS - MAY 1973

From
"The Loyalist City Amateur Radio Club Bulletin,"
May 1973

Radio amateurs across New Brunswick and in Saint John responded to Fredericton's call for assistance, on the last weekend of April, and about ten operators with equipment headed up river, followed closely by many operators from the Moncton area, who had to travel via Saint John, due to flooding of the Trans-Canada highway. While these operators were up river, the Saint John operators got the order from the Emergency Measures Organization in Fredericton to mobilize, which they did within an hour, eventually providing communications from two fixed central locations, with about fifteen actively participating, and with another ten on standby, preparing equipment and readying for watches, if needed. Due to the less critical situation in Saint John, many operators in strategic jobs could only obtain time off if the situation became critical, which it did not.

A superb job was done by all, and the Premier was heard on radio, thanking ALL who assisted, including the amateur radio operators.

No one really expected such a drastic situation, but with high spring tides in the Bay of Fundy, into which the river empties, and an extremely heavy rainfall in a short period of time, the narrow portions of the upper river valley quickly spilled over onto the lowlands along its banks. Seasoned veterans of disaster and communications could picture the problems, from information funneling through, and they could see the eagerness and often panic of the novices in some of these situations; however, they did their best, and a fine job.

The press also responded, but sometimes in confusion, due to the number of clubs and individuals looking for correct recognition. The local newspapers' lumping of the amateurs and C.B.ers in the same barrel didn't help matters; but the C.B.ers also contributed and did a fine job.

After all the panic eased, a meeting was hastily set up, which was supposed to represent all the amateurs

who participated and contributed to the flood communications, but the meeting seemed to be extremely biased towards VHF operators, and was not truly representative of all participants. Nevertheless, a liaison and discussion committee arose out of this emergency preparedness meeting, which is excellent.

What is really disheartening is the attitude of some, that one form of operator or equipment is better than another. In total communications logistics the overall view must be seen. Granted, in this instance there was a definite need of some VHF communications, but lower frequencies were also needed. The next situation may have entirely different requirements.

From listening to different viewpoints, it appears many have forgotten we are AMATEURS, and this is our HOBBY. In an emergency, radio amateurs are ONLY called in when the commercial circuits and professionals cannot handle the situation. Many local hams are now dreaming of getting into the pseudo-professional side of communications and receiving vast quantities of equipment. Is this the answer?

Communications and radio logistics is an extremely complex field, and should be treated as such. What the E.M.O. must quickly decide is what communications they require, and how they shall obtain it. Would it not be better for the E.M.O. to set up radio links and have portable equipment available to certain government agencies, then request operators, if needed? Possibly we amateurs should begin to learn proper communications procedures and deflate our egos, thus learning discipline and solidarity. A lot of soul searching and planning is again needed, as we move back into preparedness, after many idle years.

Lorne Titus VE1IN
Saint John

EMERGENCY COMMUNICATIONS PLANNING OFFICERS' CONFERENCE

Arnprior, Ontario, Feb. 6 - 8, 1973

THE MANAGUA EARTHQUAKE

AMATEUR OPERATIONS IN AN EMERGENCY AND THE PROBLEMS ENCOUNTERED

Ron Belleville, VE3AUM

HOW I GOT INVOLVED.

On the morning of Saturday, December 23, 1972, as is my usual practice, I turned on my set and took a listen around the 80 meter band. I overheard a couple of the amateur stations discussing the terrible disaster that had occurred sometime during the early morning at Managua, Nicaragua. First reports were that a severe earthquake had levelled the city, many thousands were dead and that the city was still burning, and what made me even more interested was the fact that they were saying that the only means of communications in and out of the disaster area was amateur radio.

I switched to 20 meters to see if I could get more information about this terrible news and it did not take very long to find out that the only topic of conversation across the whole band was about Managua.

I listened for some sort of emergency net operation, but could not find any, and soon discovered that many Managua stations were on the air and requesting help wherever they could find it. It was pretty chaotic until a Florida station assumed net control and tried to get some sort of organization out of the whole mess. Then at least the number of people all talking at once was greatly reduced and things began to take shape. But I must also point out that this type of net was now taking place all over the band with no co-ordination between any of them.

I decided to stick with this particular net and listen and it was not long until I heard a Managua station requesting a Northern United States or Canadian station to handle traffic. I replied and traffic was passed to my station. My first piece of traffic was for a lady in Winnipeg informing her that her son and his family were safe and sound and that she was not to worry, that they would get in touch with her as soon as things returned to normal. On receiving this news she broke into tears.

I then decided that there must be other Canadians, possibly in Ottawa who would be worried about loved ones in the disaster area. I called the local radio station and asked them if they would broadcast that I had contact with Managua and would be very happy to try and help anyone in any way I could. The station agreed and shortly after the broadcast was made my phone began to ring and requests were coming in fast and heavy, mostly from people fearing for the welfare of family and friends in Nicaragua. The calls came from as far as Grimsby and St. Adele in Quebec. One such request was from the Nicaragua High Commissioner in Montreal who told me that he could not get anyone in Ottawa, meaning of course the Government, and would I please help him. I would estimate that I handled approximately 40 to 50 requests. Other Canadian amateurs were also doing the same sort of thing but it was not until the 26th (I think by then I was getting pretty tired!) that we attempted to organize some sort of network and co-ordinate our effort towards a common goal.

Being in Ottawa, I was asked if I would handle official traffic for the federal government. However, receiving traffic and delivering it are two horses of different colours! After several frustrating attempts to reach anyone of importance to whom I could deliver the official traffic received, I finally found myself in a position of being able to deliver. On December 27th (a working day) I was put in touch with a gentleman in External Affairs who offered to accept my traffic. I was relieved but not completely satisfied, for I must admit I had the feeling I was being paid lip service and nothing more.

Messages relating to health and welfare were a minor problem as most could be passed on established amateur nets (unofficial) or by telephone. Most calls were made collect but some amateurs were making calls billed to their own phone.

Things pretty well carried on until after the New Year holiday after which time I could only assist in the evenings. Other Ottawa operators assisted in the operation. Howard Poole, VE3VP, looked after things while I was at work and Dan, VE3EMO, helped in many ways.

MAIN CONCERN BY CANADIAN AMATEURS.

The main reason for concern by the amateurs was the complete lack of organization shown by world wide amateurs at the time of the disaster. Complete chaos on the bands developed, particularly during the first few days, in spite of the ARRL emergency organization and in spite of the tremendous potential available from amateur radio to speed help to the victims of the disaster.

First, a suggestion for official recognition of the usefulness of amateur communications by the Department of External Affairs and the Department of Communications for both domestic and international emergencies, in the provision of equipment and facilities to be readily available to the amateur at strategic locations throughout Canada.

Also, to alleviate chaos in the future, it is suggested that a recommendation should be made by the Canadian Amateur Radio Federation to the Department of Communications that a band of international emergency frequencies be established on all amateur bands, for example -

15 Meters - 21.245-21.255 Mhz

20 Meters - 14.195-14.205 Mhz

and that these frequencies be monitored by all qualified stations for the first five minutes of every hour for emergency calls.

Any government recognizing amateur radio may call for a state of emergency and have full access to these frequencies.

Secondary frequencies should also be established for non-official traffic such as health and welfare and so on.

A National Emergency Co-ordinator would be appointed to operate networks for regional, national and/or international networks and the Department of Communications could issue a list of same to all qualified amateurs. This is suggested to limit the areas of emergency traffic as well as to submit a format whereby stations who wish to assist may monitor and reply on call.

These few suggestions are put forward not as an end-all but possibly the beginning of an organized amateur emergency network where, should another disaster such as that in Managua occur, amateurs could be used to their full potential. Please let us help.

SASKATOON EMERGENCY MEASURES ORGANIZATION

Operational Plans
For
Hospital Disaster Test

"OPERATION CRASH"

Bill Parker
Assistant Director, EMO



THE CITY OF SASKATOON

EMERGENCY MEASURES ORGANIZATION
612 - 11TH STREET EAST
S7N 0G3

SASKATOON, SASKATCHEWAN
PHONE 652-8411

June 1, 1973

Mr. Doug Burrill
151 Fanshaw Avenue
Ottawa, Ontario

Dear Doug:

We have just completed a most fascinating Emergency Hospital Test Exercise, and I am enclosing the following writeup in our local newspaper.

I am very pleased with the coverage given, as to hit the third page on the Star is like hitting the front page in most newspapers. We also had extensive coverage of television and radio, so I must say the media supported us whole heartedly. However, my main concern in sending this to you is to mention that we used the Communications Plan of the Saskatoon EMO that you are familiar with and it was most successful.

We controlled the Fire, Police, Engineers, etc. on the Commercial leg of our plan and used the volunteer services of Amateurs, CB's to supply the communications needed between the hospital, disaster site, etc. The entire Amateur Communications System was in operation within twenty-two minutes into the disaster. This is with no forewarning and no lead time for any of the operators. They were called on a phone fan out system.

I am extremely pleased with the results of this exercise, and I am calling a critique next Tuesday morning of the Communications Personnel to ask their advice on any improvements that can be added to or changed within the Saskatoon Communications Plan.

Just thought I would keep you in touch with things. Many thanks for your concern and co-operation.

Yours sincerely,

Bill Parker
Assistant Director

BP/sev
Enclosure

Operation Crash

Saskatoon Star-Phoenix
May 31/73

Emergency resources tested

A simulated disaster struck Saskatoon Wednesday when a DC-9 crashed into CN Towers shortly after take-off, mobilizing the city's emergency resources.

"Casualties" began arriving at University Hospital 10 minutes later as part of the first big surprise manoeuvre, designed to test the hospital's ability to receive and provide emergency services for an unexpected number of seriously injured people beyond their normal workload.

Operation Crash, organized by the Saskatoon Emergency Measures Organization (EMO) in co-operation with St. John's Ambulance, the Red Cross, Salvation Army and other voluntary service groups, was only the beginning in the development of an extensive disaster preparation scheme in Saskatoon.

St. Paul's and City hospitals will get a chance to test their disaster plans at a later date, also unannounced.

"Only 35 of the 139 hospitals in Saskatchewan actually have a disaster plan," Dr. Abram Krahn, director of EMO's Health Service Saskatchewan, told a press conference prior to the exercise.

"Our ultimate objective is to improve the standards of emergency care throughout the province."

About 60 "casualties," primarily nursing students from the Saskatchewan Insti-

tute of Applied Arts and Sciences, were prepared for their role at the University of Saskatchewan gymnasium by professional make-up people of St. John's Ambulance.

"Injuries" ranged from simple cuts and bruises to broken bones, open wounds, serious burns, protruding organs and shock.

There was an atmosphere of quiet misery and anticipation in the gymnasium and the "injuries" looked so real that one photographer remarked, "I'm just glad I didn't go to lunch today."

The "injured" were instructed to act according to their injuries. "Some of them are told to be hysterical," explained Berks Porteous, one of EMO's first aid officers.

The manoeuvre involved emergency communications, police traffic control, fire trucks and personnel for rescue and fire fighting, local ambulances and other vehicles commandeered to provide transportation.

Professional personnel acted as welfare officers to make sure the simulated casualties did not suffer unnecessary hardships as the result of weather, delays or transport and they judged ambulance operators on casualty handling.

Doctors and nurses, given 10 minutes to organize, were standing by when the first "casualties" began to arrive.

Soon the hospital's corridors were crowded with staff, stretchers and observers.

The "casualties" were first taken to the reception area in the Cancer Clinic for diagnosis, tagged and then wheeled for treatment to surgery and other areas in the hospital, including the morgue, in accordance with their conditions.

"We have a certain number of people assigned for emergency duties," explained Dr. Gordon Wyant. "We have four operating rooms and four teams of surgeons and anaesthetists set aside for emergency operations."

Doctors and nurses in the resuscitation room were calling for drugs, I.V. (intravenous) bottles and other supplies and someone was making his way through the crowds asking, "which ones are the real patients?"

The overflow from the intensive care unit was taken to the solarium.

There was no panic. But heads of departments with clip boards and sweaty brows were moving from area to area, checking and giving orders.

One nurse said people had an idea the test was coming soon. "But we didn't know it was going to be this afternoon," she said. "We thought perhaps tonight. But it was just speculation."

Dr. Wyant noticed a mix-up

where patients "in shock" were waiting in the solarium instead of receiving treatment.

Communication seemed to be a problem at one point when the telephones were jammed and when the first "casualty" was to be taken to an upper floor, the person by the elevator apparently did not know how to operate it.

"We expect things to go wrong," Dr. Wyant told newsmen and observers. "We will learn from our mistakes."

Communications and hospital personnel sat down at the end of the exercise to criticize and evaluate where things went wrong. Officials of EMO will discuss the entire operation Tuesday and announce results.

What type of disaster can Saskatchewan realistically expect?

Bill Parker, assistant director of EMO, pointed out a snow storm paralyzed Saskatoon in May 1955 and floods made Aberdeen inaccessible that year.

Fires are another possibility and, although Saskatchewan is not prone to "exotic" disasters such as earthquakes, the province has experienced tornados in the past.

"We are also quite concerned about the many chemical trucks and trains passing through Saskatoon now," he said.

SASKATOON EMERGENCY MEASURES ORGANIZATION

NARRATIVE TO EXERCISE "OPERATION CRASH"

GENERAL CONDITIONS - CITY OF SASKATOON -

Overcast

Low level cloud cover

Temperature - 62 deg.

Wind - S.E. 15 m.p.h.

TIME - WEDNESDAY, MAY 30th, 2:30 p.m.

All services in the City are functioning normal.

2:25 p.m. - Air Canada Special Flight 963 takes off south on the north-south airport runway after clearance from tower. Single engine private plane has dropped below low hanging clouds to visually locate airport and is flying in an easterly direction too low for radar detection.

Aircraft intercept north of Hudson Bay Park, damaging the elevated tail assembly of the Air Canada DC-9, and destroying the light aircraft.

2:26 p.m. - The crippled DC-9 on uncontrolled descent path collides with the CN Towers on the 5th floor level, breaking up and falling to the roof of the Mall complex.

The light aircraft crashes on unoccupied property due east of interception.

2:30 p.m. - First indication of the accident comes from a police call to the hospital. No detail given except that the Towers, the Mall and a big aircraft are burning. Many people are injured by impact, falling debris and fire.

First news flashes on radio and T/V let the public know that a serious disaster has occurred; an Air Canada Jet has crashed into the Down Town Shopping Mall and is on fire.

2:34 p.m. - City Police have taken over control of the disaster site and are pressing vehicles with drivers and spectator volunteers into action.

All available fire trucks and firemen are reporting to the scene and are helping in both rescue and fire fighting.

2:37 p.m. - St. John Ambulance, Red Cross, Salvation Army and other voluntary service groups are arriving at the Mall.

Three private cars carrying twelve casualties are the first to arrive at the hospital.

Police report indicates that casualties are being loaded in ambulances, trucks and city buses. Estimate of injured being directed to the University Hospital could be up to two hundred.

The Casualty Collecting Unit has been released to St. John Ambulance and both stretchers and blankets are now in use.

Due to the public response to the news media flashes, Line-load Control has been implemented by Sask-Tel. Only pre-selected telephone numbers can call out.

2:40 p.m. - Casualties are entering the University Grounds in large numbers.

As the injured are being directed to the three hospitals, each hospital is functioning independent of the other two.

2:45 p.m. - Line-load control is now intermittent due to reduced attempts to call out and appeal by public information news broadcasts to not use the phone.

Hospital Switchboard is overloaded due to local inquiries, relatives of aircraft passengers, and news media of Canada and USA.

The CITY of SASKATOON

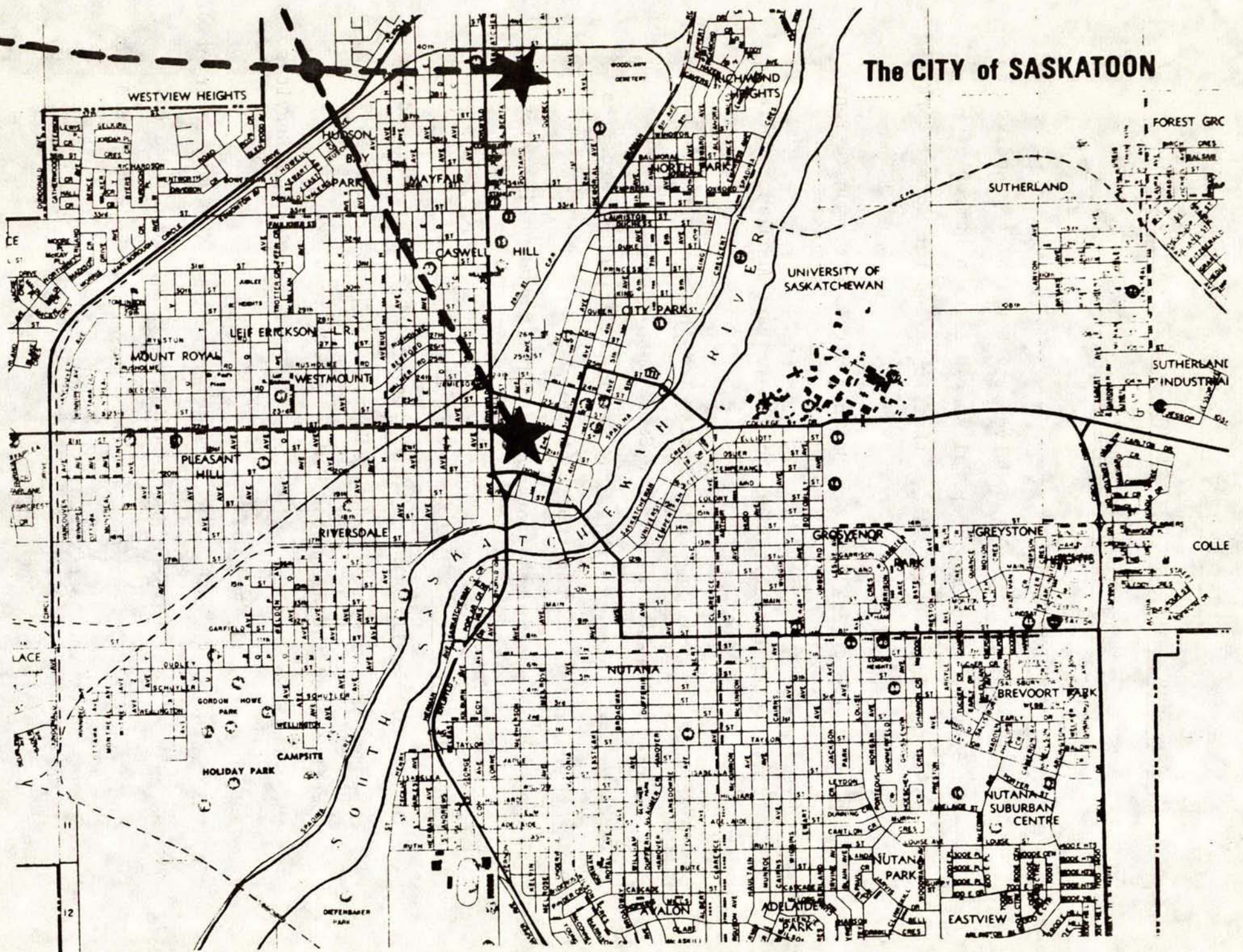

CITY OF SASKATOON

EMERGENCY MEASURES EXERCISE "OPERATION CRASH".

PRELIMINARY INSTRUCTIONS.

1. OBJECT OF THE EXERCISE.

- Test the capability of the University Hospital to receive and provide emergency hospital services for a number of seriously injured casualties that is beyond the normal workload of the hospital.
- Provide a physical test for Saskatoon E.M.O. Communications Service.
- Provide emergency training for the private Ambulance Operators in the City.
- Further the training and practice for the St. John Ambulance Casualty Simulators, and the Saskatoon Brigade.
- Stimulate interest within the Saskatoon Emergency Measures Organization and the public at large.
- Test the operational procedures of the Saskatoon District Disaster Committee.

2. DATE, TIME, PLACE, DURATION.

The Exercise will commence at a time and date to be decided upon by a joint meeting between the University Hospital Disaster Committee and the Saskatoon E.M.O. Co-ordinator.

There will be no staged disaster site as the Municipal Services are to have a limited role.

The "make-up theatre" will be so located that a realistic input of casualties will be provided to the University Hospital area.

The Exercise will end when all casualties have been admitted and processed at the hospital.

3. SCOPE OF THE EXERCISE.

This is a multi-staged exercise involving a local major disaster and creates an emergency situation for:

- local ambulances and other vehicles.
- police traffic control.
- emergency communications.
- casualty collecting.
- local hospitals (only one to be tested).
- provincial district assistance.

4. FORCES TAKING PART.

- University Hospital Staff and Auxiliaries.
- St. John Ambulance Casualty Simulators and Brigade.
- Voluntary Ambulance Services.
- Salvation Army.
- Saskatoon E.M.O. Communication Services.
- Saskatoon E.M.O. Transportation Services.
- Saskatoon City Police.
- Saskatoon Emergency Health Services.
- Saskatoon Municipal E.M.O. Disaster Committee.
- Saskatoon District E.M.O. Disaster Committee.

5. PRELIMINARY INSTRUCTIONS.

- The Saskatoon E.M.O. Co-ordinator will procure the services of volunteers for casualty simulation to the extent required by the exercise narrative.
- The St. John Ambulance Casualty Simulators will ensure that the required number of casualties will be made-up in time for exercise commencement. The simulation is to conform to the exercise narrative.
- Safe traffic control is to be arranged by the City Police from the staging area to the Wiggins Avenue entrance of the University Grounds.

- The Saskatoon E.M.O. Transportation Officer will make preliminary arrangements with volunteer ambulances and other vehicles for movement of the casualties to the hospital in a safe but realistic flow.
- The Saskatoon E.M.O. Communication Officer will ensure that a back-up communication system is available for the entire exercise as a support or substitute for the telephone services.
- The University Hospital will be responsible for conduct of the exercise within the normal jurisdiction of the hospital and in accordance with the Detail Disaster Plan 1973.
- Saskatchewan Emergency Health Services and Saskatchewan Emergency Measures Organization will assist in the exercise preparation and provide materials, moulages, litters and trestles as required by the Casualty Simulators.

6. DRESS AND IDENTIFICATIONS.

- Simulated Casualties will be provided with suitable clothing for the occasion.
- Hospital staff and auxiliaries will be responsible for their own identification.
- E.M.O. identification will be arranged for all participating emergency services.
- Exercise Referees, Directing Staff and Official Observers are to be issued with special identification so they may have free access to all areas.

7. SASKATOON E.M.O. EXERCISE CO-ORDINATOR AND STAFF.

The following personnel are responsible for the preparation and control of the exercise, but will take no part in the exercise proper -

- Saskatoon E.M.O. Exercise Co-ordinator will stage the exercise and chair both the briefing and the general E.M.O. critique.

- Casualty Welfare Officers and Umpires will be named from professional personnel. They will see that the simulated casualties suffer no unnecessary hardships as a result of weather, delays, handling or transport. They will judge ambulance operators on casualty movement.
- Emergency procedures of the University Hospital will be observed by appointed professional personnel.
- The Saskatoon St. John Ambulance Casualty Simulators will name one member for overall co-ordination of the simulation of casualties. Simulators from other cities will be asked to perform under his/her direction.

8. EXERCISE BRIEFING.

Exercise briefing will take place in the Saskatoon Emergency Measures' Headquarters one hour prior to the exercise commencement. This meeting will be of prime importance to news media, directing staff and official observers.

9. POST EXERCISE ARRANGEMENTS.

- Exercise "Operation Crash" will be considered ended -
 - (a) When the last casualty has been attended to in the hospital.
 - (b) If, in the judgment of the Umpires, the exercise has accomplished its full purpose, or, has become so bogged down that the intended objectives cannot be achieved.
- Simulated personnel will be returned to the make-up theatre and officially thanked for their efforts.
- The University Hospital will immediately conduct an "in camera" critique of the hospital operation.
- The Communications Service will conduct its private critique on the communication portion of the exercise.

- A general E.M.O. critique, that includes all participating services, will take place at a time and place to be arranged by the Saskatoon E.M.O. Exercise Co-ordinator.
 - A complete summary of the exercise will be prepared by the Saskatoon E.M.O. Exercise Co-ordinator for publication and municipal records.
-

EXERCISE "OPERATION CRASH"

SASKATOON EMERGENCY MEASURES ORGANIZATION

COMMUNICATION INSTRUCTIONS

- University Hospital
- Saskatoon Emergency Measures Organization

All exercise communications are to be prefixed with the words "Operation Crash" so that regular telephone calls will not be confused with exercise telephone calls.

Five minutes into the disaster, the University Hospital and Saskatoon E.M.O. will receive first notification of the accident. This will come from the City Police.

From ten minutes into the disaster, only line-load control telephones will make out-going exercise calls. All other telephones will be used for regular calls only.

From fifteen minutes into the disaster no telephone is to be used for purposes of the exercise.

EXERCISE "OPERATION CRASH"

SASKATOON EMERGENCY MEASURES ORGANIZATION

COMMUNICATIONS INSTRUCTIONS

Communications Requirements

1. Two meter radio from hospital to disaster site (University gym).
2. Two meter communications from hospital to EMO headquarters building.
3. Two meter communications between each of the three sites.
4. Back-up communications must be available.

Communications Instructions parallel to, but not part of two meter exercise

- CB communications involved.
- Roving mobile units available - to be contacted via two meter hospital net through EMO headquarters.
- Citizens Band Radio may be required to support two meter effort.
- Maximum use of CB net suggested during exercise.

EMO Headquarters Building

- Maximum use of this new upstairs communications facilities.
- Outside co-ordinators from District 6 will be available in Saskatoon to view this exercise. These people will be in and inspecting EMO headquarters.
- Communications between ambulance and EMO headquarters should be investigated.

EXERCISE "OPERATION CRASH"

SASKATOON EMERGENCY MEASURES ORGANIZATION

CHECK LIST

1. Obtain a suitable Casualty Make-up area.
2. Provide required volunteers as Casualties.
3. Arrange for required number of Casualty Simulators.
4. Arrange for local St. John Ambulance Brigade First Aiders.
5. Arrange transportation of out of town Casualty Simulators.
6. Provide meals and refreshments for out of town Casualty Simulators enroute to Saskatoon.
7. Provide out of pocket costs reimbursement to Casualty Simulators.
8. Provide miscellaneous refreshments for voluntary casualty persons prior to exercise.
9. Obtain used clothing of type required for casualties.
10. Provide Casualty Make-up materials.
11. Provide litters, trestles and blankets as required for Casualty Make-up.
12. Arrange for return of Casualties to Make-up theatre on completion of the exercise.
13. Have Exercise official thank the Casualty Simulators, the Casualty Volunteers and the St. John Ambulance Brigade for their part in the Exercise.
14. See that all Casualty volunteers have a means of transportation to their residence.
15. Arrange for adequate traffic control from the Make-up theatre to the University Grounds.
16. Have security personnel available to the University Hospital and Ellis Hall upon request.

17. Arrange for traffic control within the University Grounds.
18. Have Volunteer Ambulance Services participate in the Exercise.
19. Provide a variety of vehicles to transport the simulated casualties from the Make-up theatre to the University Grounds.
20. Collect the litters, trestles and blankets for return to Sask. E.M. O.
21. Collect Casualty Make-up materials for return to the St. John Ambulance Brigade or the loaning agency.
22. Provide a list of all volunteers participating in the Exercise for purposes of Workmen's Compensation.
23. Provide insurance policy for casualty volunteers under 16 years of age.
24. Notify the Saskatoon Disaster Committee of the briefing.
25. Conduct a fan-out exercise for the Saskatoon District Disaster Committee to attend the briefing.
26. Set up the detail for the briefing.
27. Conduct the exercise briefing.
28. Establish the list of Official Observers.
29. Establish the list of Exercise Umpires.
30. Provide a preliminary news media conference prior to the briefing.
31. Establish the list of news media to cover the total Exercise.
32. Schedule the Official Observers, Exercise Umpires and News Media so that a total coverage of the multi-stage exercise is covered.
33. Complete all details for the Communication phase of the Exercise.
34. Provide advance detail of the "Communication Instructions" to the University Hospital Switchboard Operators.

35. Arrange "Out of Order for Exercise Purposes" cards for the University direct line, line-load and pay phones. ~~~~~
36. Maintain close liaison between the municipal departments, hospital, local support services and Sask. E.M.O.
37. Maintain close liaison between Saskatoon E.M.O., Saskatchewan EHS, and Saskatchewan E.M.O.
38. Arrange identification for V.I.P.'s, Umpires, News Media.
39. Arrange identification for Saskatoon E.M.O. Emergency Services.
40. Provide an appropriate and authentic Narrative to cover "Operation Crash".
41. Provide "Preliminary Instructions" to the Exercise.
42. Provide "Communication Instructions" to the Exercise.
43. Provide "Exercise Schedule" for distribution at the briefing.
44. Provide critique sheets for use by the Umpires when judging Casualty Handling, Hospital Procedures and Communication Capabilities. ~~~~~
45. Schedule Critique for the University Hospital that includes invite to Umpires and selected Official Observers.
46. Schedule Critique for the Communications Phase of the Exercise that includes the selected Umpires and Official Observers.
47. Schedule an overall exercise critique that includes representation from all active participants and such selected Umpires and Official Observers as may contribute to the discussion of the Critique.
48. Arrange for a Chairman for each of #45, #46 and #47.
49. Provide a written report of the University Hospital Critique.
50. Provide a written report of the Communication Critique.
51. Provide a written report of the Exercise and the overall exercise critique for municipal and provincial records.

ANNEXES - PART V

WORKING GROUP AND OTHER RELATED PAPERS

Annex

- 23 - Designation of Amateur Frequencies for Peacetime
Emergency Use
 - Steve Chisholm, VE4AI
- 24 - Emergency Operations; Extract from FCC Amateur
Regulations
- 25 - Power Sources for Emergency Communications
 - Ken Rolison, P. Eng., VE3CRL
- 26 - Notes Regarding Radio Interference From Power Lines
 - Ken Rolison, P. Eng., VE3CRL
- 27 - "Co-operation Between the Amateur Experimental Service
and Emergency Agencies"
- 28 - Amateur Radio in Canada; Its Organization and Role in
Emergency Operations
 - Doug Burrill, VE3CDC
- 29 - The Canadian Amateur Radio Federation - A Short History
 - Art Blick, VE3AHU
- 30 - The "Teague" Bill, U.S. Congress, House of Represent-
atives' Bill HR3516 to require that radio and television
receivers meet certain technical standards for filtering
and interference, including all interference from
amateur stations.
- 31 - A Recommended Message Form for Canadian Amateurs
 - Art Blick, VE3AHU
- 32 - Extracts from "The Effects of the Electro-Magnetic
Pulse Generated by Nuclear Weapons", published by
the U.S. Defense Civil Preparedness Agency.

DESIGNATION OF AMATEUR FREQUENCIES FOR
PEACETIME EMERGENCY USE

S. C. Chisholm, VE4AI
Red River College, Winnipeg

History of use in Canada

There is no Canadian usage known but in the USA there is a Federal policy applicable to all areas with appropriate administrative procedures which allows certain designated bands to be declared emergency frequencies and to be kept clear for traffic, usually below the US phone band. (See Annex 24)

Requirement

That a similar system of designating a frequency or frequencies in various amateur bands be set up in Canada to work in conjunction with Canada Emergency Measures Organization.

Factors

- (a) Who decides what is an official emergency?
Federal or provincial or municipal governments, or a combination?
- (b) Method of notification of declared emergency to all citizens
- (c) Planning and pre-designating of frequencies
- (d) Pre-notification to all amateurs
- (e) Pre-designation of certain amateur stations as operations control stations

Pre-planning of frequencies can be carried out by a representative group of Amateurs who are active on the various bands. Such frequencies should be Canada-wide with notification to individual Amateurs. Full publicity on a continuing basis will ensure the frequencies are known and hence well respected. Practical arrangements can be made for policing, by Amateurs, where necessary.

The Canadian Amateur Radio Federation (CARF) and Canada EMO should decide on a regional basis just what the requirement for communications by Amateurs will be.

Co-Ordination at Federal Level

CARF Liaison - DOC - DND/EMO

CARF Input (after co-ord with provincial societies)

- (a) Frequencies
- (b) Stations in each Regional (Provincial) area

DOC Input (a) Co-ordination with other government departments
(b) Methods of control, authorization, notification,
co-ordination and with USA agencies involved.

EMO Input Communication requirements
(a) Municipal/Provincial
(b) Federal
(c) Training

From this should come:

CARF Information to provincial societies

DOC Information to individual amateurs re frequencies,
authorization, channels, etc.
To Regional offices - delegated authorization and
names of designated local amateurs.

EMO Information to Regional EMO offices based on agreed
plans and amateur personnel in their area.

EXTRACT FROM U.S. FCC AMATEUR RULES AND REGULATIONS

VOL. IV CHAPTER 97

EMERGENCY OPERATIONS

§ 97.107 Operation in emergencies.

In the event of an emergency disrupting normally available communication facilities in any widespread area or areas, the Commission, in its discretion, may declare that a general state of communications emergency exists, designate the area or areas concerned, and specify the amateur frequency bands, or segments of such bands, for use only by amateurs participating in emergency communication within or with such affected area or areas. Amateurs desiring to request the declaration of such a state of emergency should communicate with the Commission's Engineer in Charge of the area concerned. Whenever such declaration has been made, operation of and with amateur stations in the area concerned shall be only in accordance with the requirements set forth in this section, but such requirements shall in no wise affect other normal amateur communication in the affected area when conducted on frequencies not designated for emergency operation.

(a) All transmissions within all designated amateur emergency communication bands other than communications relating directly to relief work, emergency service, or the establishment and maintenance of efficient amateur radio networks for the handling of such communications shall be suspended. Incidental calling, answering, testing or working (including casual conversation, remarks or messages) not pertinent to constructive handling of the emergency situation shall be prohibited within these bands.

(b) The Commission may designate certain amateur stations to assist in the promulgation of information relating to the declaration of a general state of communications emergency, to monitor the designated amateur emergency communications bands, and to

warn non-complying stations observed to be operating in those bands. Such station, when so designated, may transmit for that purpose on any frequency or frequencies authorized to be used by that station, provided such transmissions do not interfere with essential emergency communications in progress; however, such transmissions shall preferably be made on authorized frequencies immediately adjacent to those segments of the amateur bands being cleared for the emergency. Individual transmissions for the purpose of advising other stations of the existence of the communications emergency shall refer to this section by number (§ 97.107) and shall specify, briefly and concisely, the date of the Commission's declaration, the area and nature of the emergency, and the amateur frequency bands or segments of such bands which constitute the amateur emergency communications bands at the time. The designated stations shall not enter into discussions with other stations beyond furnishing essential facts relative to the emergency, or acting as advisors to stations desiring to assist in the emergency, and the operators of such designated stations shall report fully to the Commission the identity of any stations failing to comply, after notice, with any of the pertinent provisions of this section.

(c) The special conditions imposed under the provisions of this section shall cease to apply only after the Commission, or its authorized representative, shall have declared such general state of communications emergency to be terminated: however, nothing in this paragraph shall be deemed to prevent the Commission from modifying the terms of its declaration from time to time as may be necessary during the period of a communications emergency, or from removing those conditions with respect to any amateur frequency band or segment of such band which no longer appears essential to the conduct of the emergency communications.

C.E.M. College
Auriprior, Ontario.

May, 1973

Power Sources For
Emergency Communications

K.E. Rolison P.Eng.
Canadian National Telecommunications

The major problem facing any communications system is its ability to maintain or to establish usable communications to necessary standards at any time, even under the most adverse conditions. This holds true whether the system is that of a common carrier, (Bell or CNT), a Public Utility (such as a Power Commission) or constitutes supplementary services such as EMO. Amateur, general radio service or other system primarily of interest during emergencies or emergency exercises. The ability to maintain communications under adverse conditions is part of the day to day concern for reliability of the carrier or Public Utility system. A considerable body of experience has been obtained by the owners of these systems. Some of this experience is directly applicable, to the operation of emergency or disaster oriented systems.

While often overlooked by both users and designers of communications systems, the supply of power necessary to operate the system, is probably the single most important factor in the maintenance of communications. The power source is in fact the cardiovascular system of communications. If the power system is healthy and operational many problems in other areas can be tolerated or adjusted for, and communications can be maintained. A failure of the "heart" of the system guarantees a total failure of communications - a "D.O.A." - to use the medical metaphor again.

Emergency communications, in all probability will be, in the main, by radio. Depending on the type and scope of a disaster, other forms of communications can be expected to be totally prostrated or severely crippled in the affected area. Under such conditions power becomes vitally important. Disasters affecting wire line and cable facilities can be expected to equally affect the power utilities ability to supply power. With the umbilical cord severed, the emergency communications "baby" must be able to survive and function independently.

Some of the power protection concepts used by the carriers and utilities are directly applicable to the emergency communications. Some are not, but will prove thought-provoking and may lead to other practical concepts for emergency powering of communication equipment. I propose therefore to review some of the power concepts employed commercially in the hope that this will stimulate discussion and perhaps generate some new or novel approaches for emergency communications:

Power for communications can be categorized under two broad classifications:

Classification 1. Duration of Operation

(a) Prime Power Plant

A local power generating source which must be functioning at all times when communications are required, owing to the lack of commercial power (or power from other than communications sources) at the particular location.

In the event of prolonged operation this type of power is made redundant by the provision of two (or more) primary generating units, or a mobile unit, to permit necessary maintenance.

(b) Standby (or Emergency Power)

Locally generated power plant provided for use during periods of commercial power outage only. This type of unit can be automatic or manually operated. The commercial trend is for automatic starting and switching.

Under both these categories (a and b) a short break in power is experienced during transfer from the normal supply to the alternate, and during restoration to the normal source.

(c) No Break Power (UPS System)

This provides for power at all times from either of two sources i.e. commercial power, standby power or alternate prime sources, without any interruption being experienced during changes of source.

Classification 2. Supply Requirements of Radio Load

(a) Direct Current Supply

This group includes supplies to furnish Direct Current usually at 12, 24 or 48 volts to radio equipment. Most mobile equipment falls into this category with 12 volts usually being required. The commercial systems involve fixed installations in large offices requiring 24 or 48 volts usually.

(b) Alternating Current Supply

This group includes supplies for base stations point to point VHF or UHF fixed stations, SHF (microwave) terminals and repeaters, and, of course, the normal broadcast services.

Either (a) DC or (b) AC supplies above can be designed as part of an integrated power system satisfying any of the requirements of Classification I i.e. prime power, standby power or no-break concepts.

Commercial communications systems were in early days based on the supply of power as Direct Current to landline terminal and repeater equipment. Common supplies were at 24 or 48 volts and 130/260 volts DC. With the advent of radio into the commercial field, its load requirements were for AC. Following the invention and general acceptance of transistors, radio loads, now much decreased, tended to change, for low power RF outputs to DC requirements, at 24 or 48 volts, or for mobile base stations at 12 volts. Considerable savings were achieved, not only due to the lower drains and elimination of tube heater requirements, but also due to the elimination of the "power pack" with its transformer and rectification losses.

Higher powered equipment still normally requires AC supply.

DC Power Supplies

These are either unbatteried rectifier supplies or as is the usual practice provided with batteries floated across the discharge bus. The rectifiers employed are silicon units connected in full wave bridge configuration. Small units are single phase devices, relay rack mounted. Large capacity rectifiers have three phase inputs with the transformer primary connected to the 120/208 volt 3 phase 4 wire AC supply.

The rectifiers are fitted with inherent current limiting, set at about 115% of their full load rating as well as the normal input (AC) and output (DC) circuit breakers. 1% Voltage regulation is provided using magnetic amplifiers with saturable core reactors as the main regulating component. Filtering is provided to keep RMS ripple below 0.1% of the output DC voltage.

The addition of a battery provides limited duty emergency protection during power failures. Batteries are low specific gravity (1.205 to 1.220) lead acid cells, so chosen for their ability to be float charged at 2.15-2.18 volts per cell. The use of low gravity electrolyte and controlled voltage floating gives battery life of ten years or more.

TYPICAL 24 VOLT BLOCK DIAGRAM.

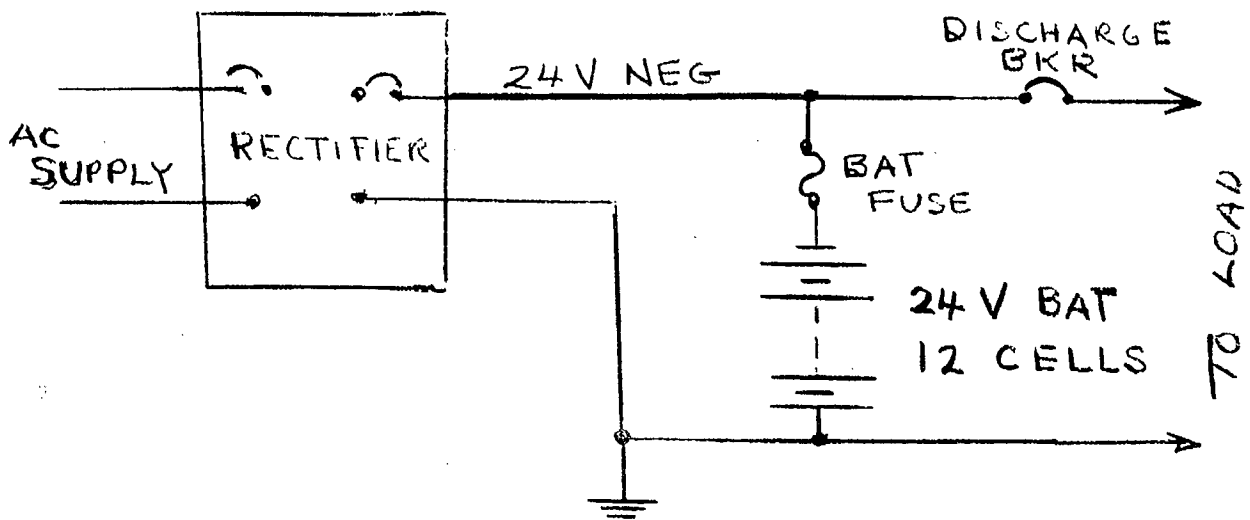

ALL BREAKERS AND BAT FUSE ARE ALARMED

Where alternate sources of AC are available (ie Hydro - Standby Generator) battery reserve of 3 hours is provided. Otherwise 8 hours or more reserve is the rule.

One problem with DC battery supplies that must be considered is the inherent voltage changes that occur in the battery between discharged condition and floated condition, and occasionally the higher voltages required to "equalize" the battery in order to maintain its effectiveness, and correct deterioration due to internal "local" chemical reactions. For example, cell voltages are; discharged 1.84, charged open circuit 2.00, floated 2.15 and while being equalized 2.25-2.33 volts per cell. For a 12 cell 24 volt battery this represents voltages of 22.08, 25.8 and 27 - 28 volts. The equipment being supplied with power must be capable of operating with such voltage variations, or supplementary voltage regulation must be provided.

The battery is a short time energy storage device. The DC approach to power supply satisfies however, the requirements of a no-break (UPS) emergency system, and when used in conjunction with alternate sources of AC power, such as an automatic engine generator set, affords long term protection which is eminently satisfactory, and probably the most economical approach to no-break power.

Other DC Power Sources

The problem of providing power for small communications loads in remote unserviced areas is of the greatest significance in Canada with its vast expanse of Arctic and Sub-Arctic areas. The problem of providing power for loads under 3KW in such locations has received considerable attention in recent years, as there is to date no completely satisfactory primary source available to fill this need.

For loads under 6 watts, standby, and slightly higher loads on transmit ie 50 to 100 watts a combination of primary and secondary cells has been used to provide all power. In this arrangement air depolarized cells are arranged so that they supply the standby radio load and charge a nickel cadmium sintered plate secondary battery. During the transmit function the higher power required is drawn from the nickel cadmium battery, as the air depolarized cells are only capable of about 1 ampere output. The success of this system depends on a low ratio of transmit to standby duty cycle.

Another approach to low power requirements is the use of thermoelectric generators, in conjunction with a storage battery. In this arrangement power is produced by heating a bismuth telluride thermocouple on one side using heat from a propane fuelled flame or catalytic burner. DC power is delivered from a converter to the battery and load.

This approach suffers from two disadvantages. First the low thermal efficiency of the unit, 2% - 4%, restricts its use to loads well under 100 watts, due to the relatively high consumption of the LPG fuel. Secondly, the loss of vapour pressure of LPG at low temperatures requires pressurization of the storage tanks in cold weather, using an inert gas such as nitrogen. In this arrangement, the nitrogen pressure drives the propane, in liquid form, from the bottom of the

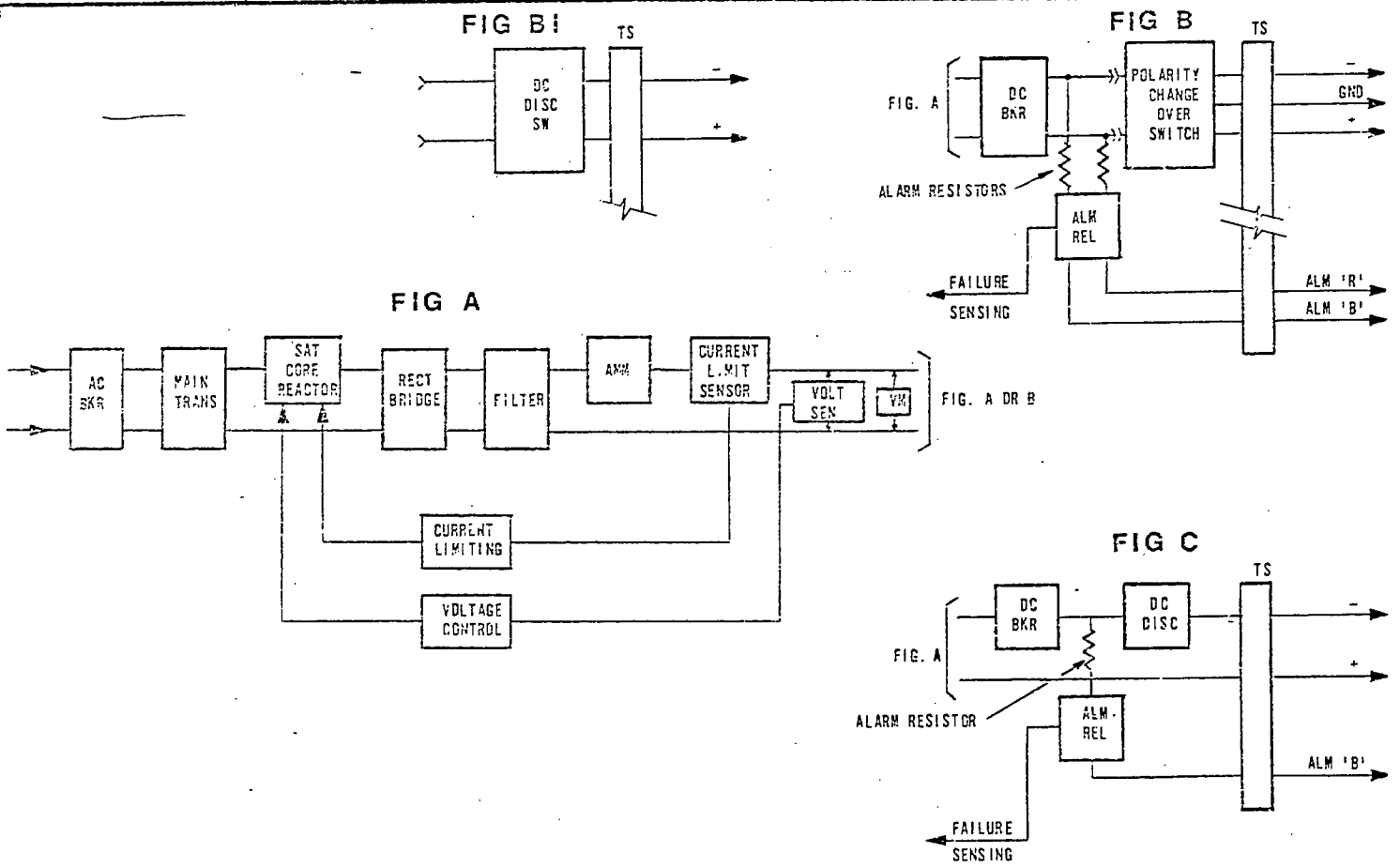

MAG - AMP CONTROL FOR 24V, 48V, FIG A AND C
 MAG - AMP CONTROL FOR GOV, 5A RECT FIG. A AND B
 MAG - AMP CONTROL FOR 50V & 120V RECT FIG A AND FIG B MODIFIED TO INCLUDE FIG. B1

	TELECOMMUNICATIONS ENGINEERING DEPT.	A
	RELAY RACK RECTIFIER R 2021-A SIMPLIFIED SCHEMATIC	
DR. C. J. CHKD <i>[initials]</i>	APPROVED <i>[signature]</i>	SP 15103-3
ENGR/ET <i>[signature]</i>	<i>[signature]</i>	

storage tank through the fuel piping. A vapourizer is required to convert the liquid LPG into the gaseous form required by the thermo electric generator burner.

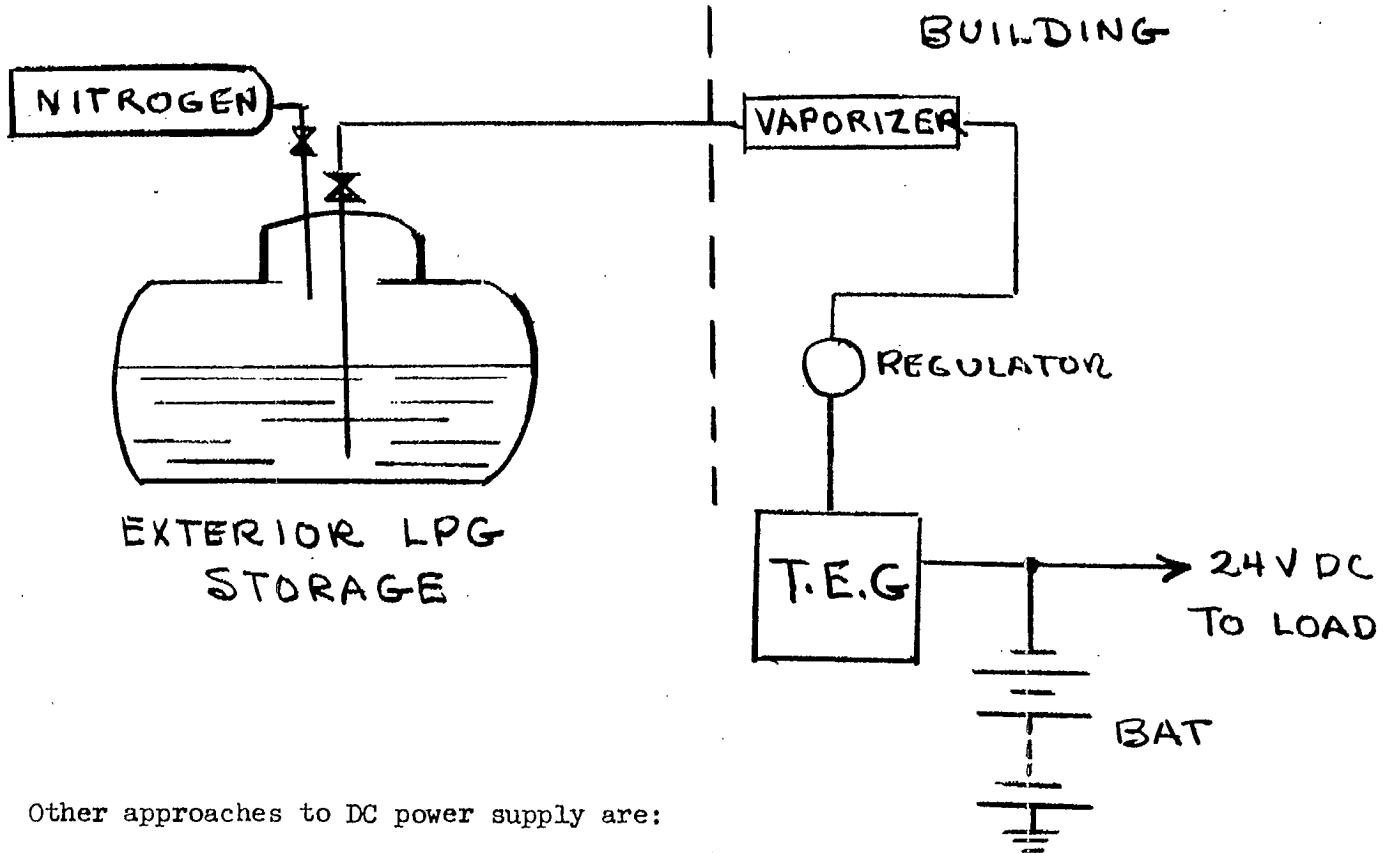

Other approaches to DC power supply are:

1. The use of wind driven generators in conjunction with a storage battery.
2. The use of what are basically small low temperature steam engines or steam turbines, in conjunction with storage batteries. In these units the "steam" is actually vapour from liquids related, chemically, to the Freon refrigerants, rather than water.
3. The use of radio isotope heat sources such as Cobalt-60 to provide heat either for a conventional thermo-electric generator or for the "steam engine" devices described above. The initial and refuelling costs of these devices are very high, but the five year operational life, and absence of maintenance indicates some applications for them in Arctic areas.

AC Power Supplies

As previously stated, the obvious approach to the provision of AC power, in the absence of conventional AC supply is by the use of engine generators. Gasoline, propane, and diesel fuelled engines have been used for this purpose. In the commercial area the practice has been to use diesel generating sets, which are more applicable to loads above 3KW than for smaller load requirements. Gasoline units have fallen from favour due to the higher fire risk, and the need for spark ignition systems, which are prone to failure, ie plugs, points, coil, etc. The propane fuelled units have one major advantage over gasoline engines, non degradable fuel, but otherwise are subject to the same limitations as gasoline fuelled units.

The application of the engine generator set as either a primary or standby source needs little explanation. It should be pointed out, however that the use of brushless alternators, and well designed electrical control devices have a marked effect on the reliability of such units. Engine generators are of course used in conjunction with the rectifier-battery combination for DC supply, thus giving no-break (UPS) features.

There are several interesting approaches involving engine generators directly as no-break AC supplies. Here the load is supplied from an alternator equipped with its own voltage regulating device. The alternator is driven either by an electric motor, from the normal AC power source or from an emergency engine which starts automatically when the normal source fails. If some form of energy storage device such as a flywheel or a DC motor and battery combination is fitted to sustain rotation of the alternator during engine starting or shut down, no-break facilities can be achieved.

If properly designed stable voltage at very close to synchronous 60 cycle frequency can be continuously supplied through power failure and power restoration.

In most of such units the engine is directly coupled to the motor alternator shaft through a clutch, as shown on the accompanying diagram.

ASYNCHRONOUS NO BREAK SET WITH INTEGRAL ENGINE

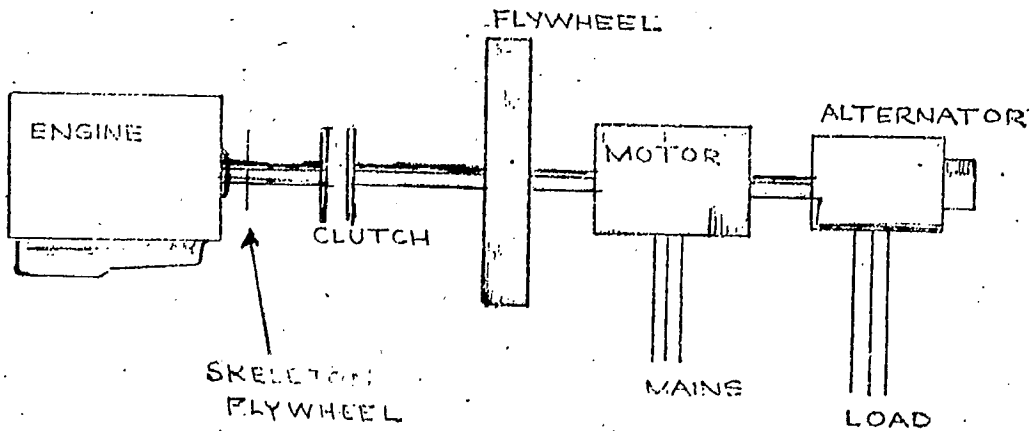

SEQUENCE OF NO-BREAK OPERATION

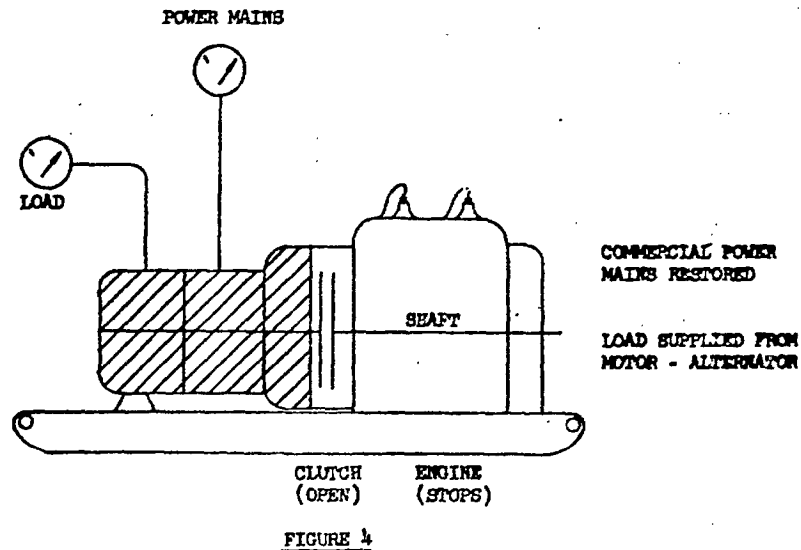
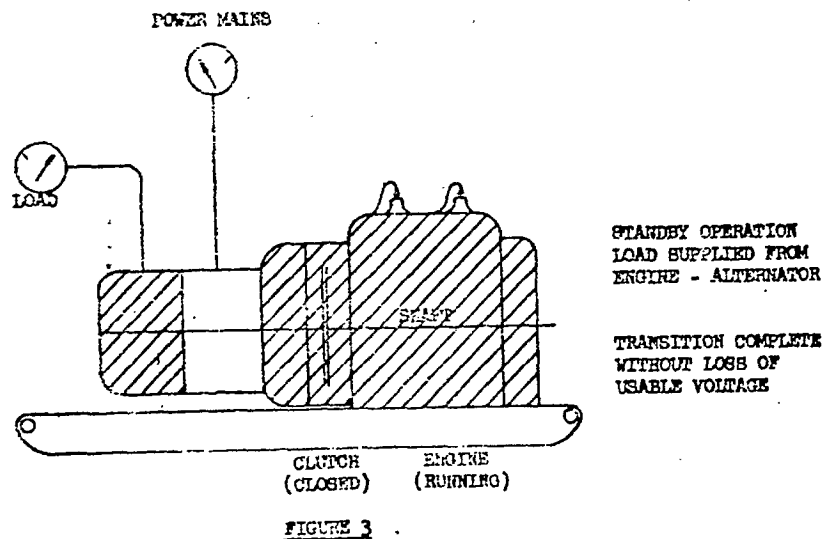
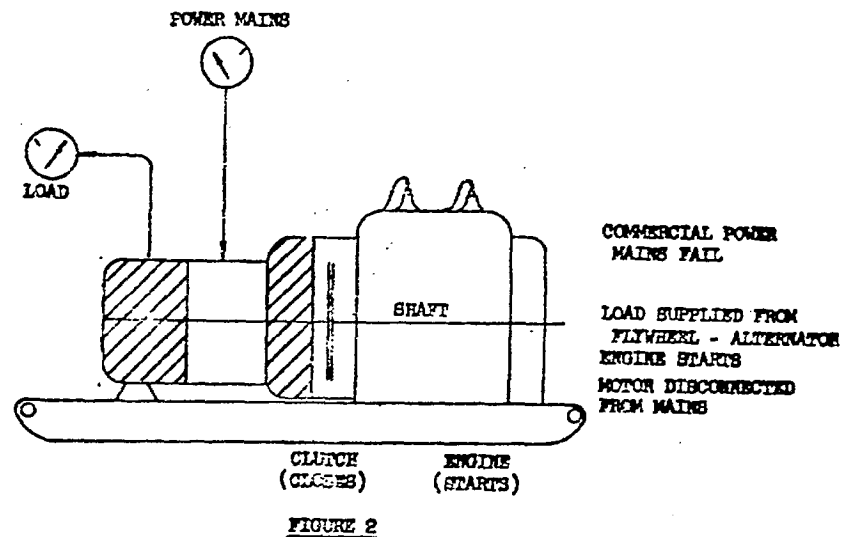
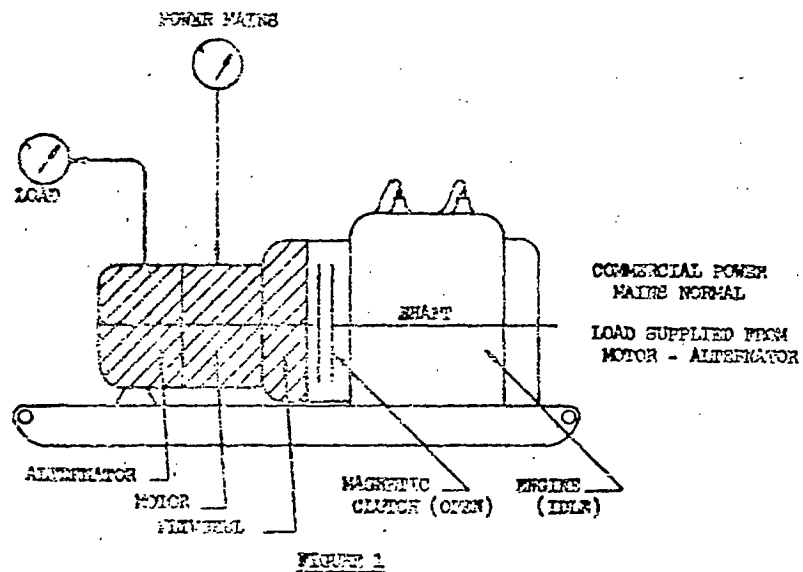

Another variation of this concept employs a separate motor-generator and flywheel, which is driven electrically either from the normal AC source or from a separate emergency engine generator set.

ELECTRICAL ASYNCHRONOUS NO BREAK SET

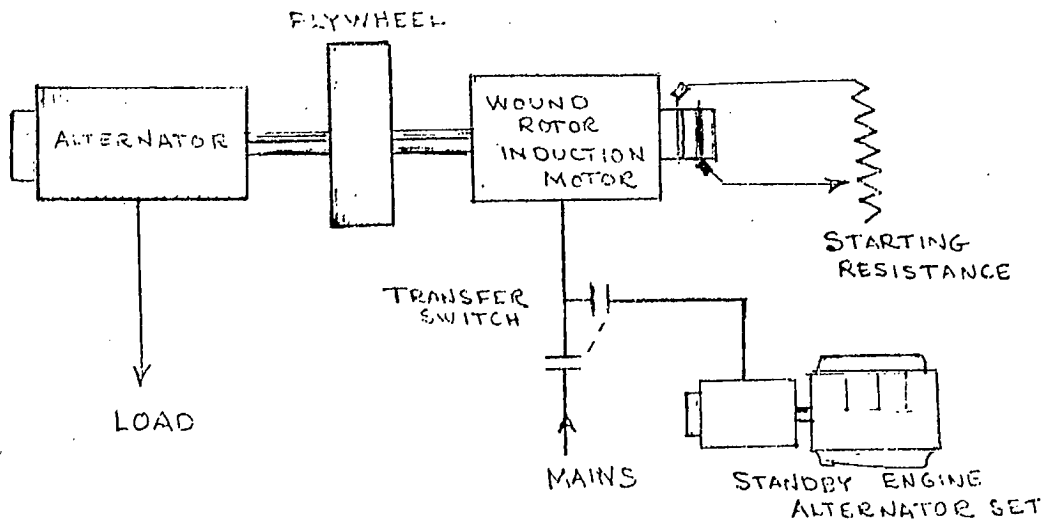

Other approaches to the production of no-break AC use a static inverter, powered from a DC supply furnished by a rectifier/battery combination. This is very acceptable for small loads under 1 KW, but in larger sizes the batteries and charging plant become quite large, due to the low conversion efficiency of the total system. Capital costs are 2 to 3 times the rotary no-break approach.

While the above cover the basic concepts used commercially for the supply of power to communications and radio systems, there are of course other factors which have to be considered. For instance modern low drain radio has reduced radio loads considerably, often to negligible proportions. In many such instances the aircraft clearance lighting required on towers exceeds many times the critical radio load. With low drain transistorized equipment, enclosure heating during commercial power failure is also presenting a problem of considerable magnitude.

It is hoped that the foregoing has proved of interest, and will stimulate increased interest in the question of power supply to radio equipment during emergencies. If we have succeeded in emphasizing the overwhelming importance of power to the operation of emergency oriented radio systems, so that this area will receive the consideration is warrants, this paper will have achieved its primary objective.

Typical Radio Equipment Power Consumption

		<u>Loads</u>	
		<u>DC 13.6V</u>	<u>AC</u>
100 Watt P.E.P. Tranceiver 1.6 - 17 MHz	Receive	.35 - 2 amps	17 - 37 VA
	Standby	5 - 6.6 amps	54 - 74 VA
	Transmit	11.5 - 14 amps	240 - 260 VA
1 KW P.E.P. Amp For above	Standby		220 Watts
	Transmit		1300 Watts

FM Base Station (Solid State)

		<u>DC 12V</u>	<u>AC 115V</u>
Low Band 50 Watt 27 - 50 MHz	Standby	1 Amp	.35 Amp
	Transmit	14 amp	3.5 Amp
VHF 30 Watts 148 - 174 MHz	Standby	450 MA	.35 Amp
	Transmit	11 Amps	1.3 Amp
UHF 25 Watts 450 - 470 MHz	Standby	1 Amp	.4 Amp
	Transmit	14.5 Amp	3.5 Amp

CEMO College
Arnprior, Ontario.

May, 1973

Notes Regarding Radio Interference from Power Lines

K.E. Rolison, P.Eng.

Acknowledgements:

Much of the resource material for these notes was supplied by the Hydro Electric Power Commission of Ontario Research Department. Thanks are due to Mr. Keith Bellamy, P.Eng. Chief Inspector for Ontario, and Mr. J. Dicker, P.Eng. for their assistance.

=====

Radio interference generated by power lines is in the main due to corona effects. Corona is defined as "luminous discharge due to ionization of the air surrounding a conductor around which the voltage gradient exceeds a critical value".

Corona on conductors usually occurs due to operation of a high voltage power line at higher voltages than that for which it was originally designed and built. However the critical voltage at which corona occurs can for a given line be lowered by several factors. If the critical voltage is thus affected corona, and radio interference due to corona, may appear on a line, which under more favourable conditions would be corona free.

Wet weather will often lower the critical voltage causing corona. Other factors affecting corona are diameter of conductors, the interphase conductor spacing and the surface roughness of the conductor. For example an increase in conductor diameter of 10% raises the critical voltage at which corona will occur by about 8%. An increase of 10% in conductor separation will raise the critical voltage by about 1%. Surface roughness tends to lower the voltage at which corona will occur, ie:

For a smooth cylinder	by a factor of 1.0
For an old cylinder	by a factor of .68 - .82
For a wet conductor	by a factor of 0.16

It can be seen that conductor corona is much more likely to occur in bad weather, not only due to the surface factor of 0.16 but also due to changing separation between conductors.

Some consideration here of conductor galloping is probably merited. Conductor galloping is due to aerodynamic forces (lift) acting on a non spherical conductor. This results in motion in the vertical plane often of peak to peak amplitudes of 10 feet. In the case of long spans movements of up to 40 feet have been observed.

While the major forces due to "galloping" are vertical, secondary horizontal motion affecting interphase spacing is also produced, with, of course, an effect on the corona critical voltage. The formation of ice on conductors tends to produce nonspherical surfaces, and the aerodynamic forces conducive to "galloping".

Measures to prevent or limit conductor galloping are the use of energy absorbing dampers attached to the conductors, or the application of other devices which tend to counteract aerodynamic "lift".

The majority of corona interference, particularly in good weather, is produced as a result of hardware corona, at insulators etc., rather than conductor corona per se. This is combatted by providing long path corona shielding on the insulators and "grading" rings on sectional insulators, which tend to restrict the voltage gradient in the surrounding air. Of course defective, dirty or wet insulators will promote corona.

Corona evidences itself as a violet visible radiation, an audible frying sound, and R.F. hiss.

Corona is measured by the power utilities in microvolts/meter using a 1 meter antenna and a calibrated receiver. Measurements are usually made at a frequency of 1 MHz.

The following pages are extracts from the Report on the federal-provincial Emergency Communications Planning Officers' Conference convened by Canada Emergency Measures Organization at Arnprior, February 6 - 8. 1973.

CO-OPERATION BETWEEN THE AMATEUR EXPERIMENTAL SERVICE AND
EMERGENCY AGENCIES

The reserve of communications equipment and the related technical and operating expertise available in the Amateur Radio Service has been utilized in a number of the emergency communications plans presented to the conference. As mentioned in the talk on the national emergency communications systems in the United States, many states, countries and municipalities depend on the semi-official Radio Amateur Civil Emergency Services (RACES) as a backup during emergencies. From the viewpoint of the emergency planner, it is most important that if amateur radio is to be used that it be properly integrated into the planning. As was borne out in the talk on the Managua disaster traffic by Ron Belleville, because it was not integrated with plans on the national level, its full potential was slow in being utilized in the actual event.

Saskatchewan would depend a lot on the Amateur Service for a backup, according to James Eaton, the Saskatchewan EMO Director, In Saskatoon, the fastest response to an emergency was the Amateur Service and some organized owners of General Radio Service equipment. The city's Assistant EMO Director, Bill Parker, gave a description of the extensive use to which amateur radio and Amateur equipment forms a vital part of his city's emergency communications.

He stressed that to integrate the Amateur operators fully into the EMO plan he believed that it was necessary to train the Amateur in EMO procedures and organization. The hospital emergency plan in Saskatoon uses amateur equipment and amateur VHF frequencies and is both exercised and actually used in emergencies under the auspices of an amateur radio club sponsored by EMO.

In British Columbia some 160 amateur stations form part of the co-ordinated system which utilizes, as required, public utility, broadcast, private and commercial stations. Six different amateur nets are used, one for each EMO Zone, each with links to the central provincial net.*

In Alberta, the EMO system employs four networks, all closely integrated with the EMO co-ordinators whom they serve. Instructions to co-ordinators and amateurs are contained in a manual issued to all concerned. All relations between the users and the amateurs are concisely covered and include the regulations for the handling of official EMO traffic and instructions for reimbursing amateur participants for out-of pocket expenses directly incurred as a result of assisting EMO personnel.

Their four networks involve 47 stations in 36 cities, towns and villages and are exercised each Sunday. **

The utilization of the present systems of VHF and UHF amateur repeaters, some of which are equipped with the latest hardware and technological improvements, was discussed by the panel as part of peacetime and wartime planning. The need for some official protection or assignment of an amateur frequency being used for emergency work was also suggested in the panel discussion as a subject to be pursued with the Department of Communications.

Four presentations exclusively on the role of the Amateur Radio Service were made on the last morning of the conference. Doug Burrill, VE3CDC, introduced the program by pointing out that public service was not one of the reasons for the existence of the Canadian Amateur Radio Service as in the case in the United States. In fact there are certain Department of Communications regulations to be observed if a Canadian amateur station wishes to engage in emergency communications. However, assistance to the authorities in time of emergency is a tradition of the Amateur Service in all countries and is certainly a prominent feature of Canadian amateur activities.

The growth of an official, distinct, Canadian national amateur organization, the Canadian Amateur Radio Federation Inc. has mushroomed during the past year and a monthly news tabloid is now published by the Federation with timely news and official information for Canadian amateurs, on an individual basis, as associate members. The Federation carries on negotiations with the Department of Communications as an officially recognized liaison agency between DOC and the amateurs.

PROBLEMS IN HANDLING EMERGENCY TRAFFIC

"The city is 80% destroyed and ten to fifteen thousand people are dead or injured"... These words coming out of the loudspeaker of VE3AUM, Ron Belleville, involved him in the emergency traffic handling created by the Managua earthquake disaster at Christmas time. One of the many Canadian amateurs who handled messages to and from the stricken city, Ron, because of his Ottawa location, was involved in the handling of a large amount of urgent official traffic for the federal government.

** See "The Manual of Peacetime Operations for Alberta Emergency Measures Amateur Radio Net" included as an Annex.

Ron gave an excellent description of the participation of Canadian amateurs in this disaster. He brought out the fact that unhappily, the formal amateur emergency nets, despite their practice in simulated emergencies, did not respond to the occasion as they might have. It took two or three days to set up a national net to handle the Canadian traffic, which eventually became largely "welfare nature.

The biggest problem was finding someone to deliver the traffic to the federal government. He eventually cleared official traffic to the Armed Forces headquarters but his frustrating experience pointed out the need for some government focal point which would be operational 24 hours, 365 days of the year and to which official traffic could be directed.

It appears that the lesson learned in this respect in this international operation would well apply to domestic crises on any level of government.

Ron is in the Communications Branch of the RCMP HQ and is Chairman of the Canadian Amateur Radio Federation National Communications Committee.

THE "AMATEUR" AS A COMMUNICATIONS ENGINEER

The full-scale participation of amateur radio operators in a county and city emergency plan was described by Art Blick, VE3AHU, who is Communications Officer for the Frontenac/Kingston EMO and President of the Canadian Amateur Radio Federation. After local contractors botched the job of installing the EMO VHF communications network the Kingston Amateur Radio Club, with a wealth of engineering and technical expertise at its command undertook the complete design and installation of the extensive Kingston/Frontenac County EMO VHF communications system.

Having completed this extensive radio system and set up a complete communications centre in the Kingston County Court House the Kingston Club proceeded to train and supply amateur operators for the emergency nets on EMO and amateur frequencies. Realizing that during business hours many amateur operators may not always be easily available, a back-up plan utilizing local taxi companies was incorporated into the EMO plan for Kingston City. By a strange quirk of fate, an exercise based on a scenario featuring an explosion and fire in a local hospital actually came true some months later and at that time the back-up plan paid off because the quick response of the taxis for communications beat the amateur organization to it. This episode merely underlined the fact that all communication resources in a community should be integrated into a plan as well as the amateur organizations.

MANY "AMATEURS" ARE "PROFESSIONALS"

Modern techniques as applied, and in some cases developed by amateurs fully justify the use of the word "experimental" in regard to this hobby, as Lyle Ward, VE3CEZ, pointed out in his review of the accomplishments of amateurs in designing and making sophisticated repeater equipment. The number of highly qualified professional people in the

electronic and physics sciences who carry their expertise into their recreation is especially large in a research centre like Ottawa.

The use and employment of FM on VHF and UHF frequencies by amateurs in their repeater systems could provide a reliable, flexible back-up system for EMO nets. A number of repeater stations now operate on 12 volts DC float-charged batteries which gives them a built-in capability for emergency use in situations where the main power is off. Their use extends the range of low-powered mobile sets up to scores of miles with reliable, noise-free phone communication.

Amateurs are presently running and communicating with their own orbiting satellite, Oscar 6. One of the four telemetry and control stations is located in Ottawa. This resulted from an emergency at the home control site in the United States and in the speedy action by an Ottawa amateur and magnificent support from interested Canadian companies. The Ottawa control facility was built up in two days and has since been improved to the extent that the control station, located in the basement of a local amateur, Larry Kayser, VE3QB, is fully automated.

While amateur satellites are an extremely interesting development both for the professionals and the "button-pushers" in the amateur fraternity, their employment in emergency work is not feasible until a stationary one is available. Lyle, who is a project officer with the Electronics Branch of the Federal Department of Supply and Services emphasized to the planners that the ability of modern solid state VHF transceivers to be used as base, portable or mobile stations independent of mains power offered a ready source of emergency communications systems available to the emergency planner.

EMERGENCY COMMUNICATIONS CONFERENCE
FEBRUARY 6-8, 1973 - ARNPRIOR
SPONSORED BY CANADA EMERGENCY MEASURES ORGANIZATION

"Amateur Radio in Canada: Its Organization and
Role in Emergency Operations"

Douglas R. Burrill - VE3CDC

The objective of this morning's program is to acquaint emergency planners with the role which amateur radio can play in assisting the civil authorities in emergencies short of war. In that case, of course, the rules are changed rather drastically and the amateur service can be completely shut down or requisitioned for the use of the civil or military authorities.

The presentations this morning will show the versatility and availability of the amateur radio operators and their equipment, the legal and administrative restrictions and problems, and a model plan for the use of the amateur service in the emergency plan of a typical Canadian city.

The Radio Act defines the amateur service as:

"being a service in which land or mobile stations are operated for self training, inter-communication and technical investigations carried on by amateurs who are duly authorized persons interested in radio technique solely with a personal aim and without pecuniary interest."

Note that public service and its use in emergency operations is NOT a justification for the amateur radio service in this country. Up until now the only amateur publications read in Canada on a national scale have been United States' amateur radio magazines. Because a main legal justification of the amateur service in the United States is "public service" - that is, assistance to authorities in an emergency, many Canadian amateurs are misled as to their own status in an emergency. In Canada there are definite regulations governing amateur activities of this nature.

Despite the fact that "public service" is NOT a justification for the amateur radio in Canada, it is very much a part of the amateur philosophy indeed. The individual operator is always eager and willing to put his combination of communication equipment, knowledge and skill to good use in an emergency. This service is a tradition held throughout the world-wide amateur fraternity.

It has been said that the amateur operator is too much an individual to be organized and incorporated into an emergency organization. However, the amateur traffic organizations and networks are efficient, and well-run and their participants can form the basis of ad hoc or previously organized emergency networks which can be of great use in an emergency. As an example, about five or six years ago on a spring morning there were FORTY THOUSAND people on the move on foot in the City of Ottawa in its first "march for charity." The sponsoring organization was not too well prepared to meet either the unexpected scope or the variety of the resulting problems of food, transportation and casualties which ranged from sore feet to heart attacks. Fortunately, however, the sponsors had previously asked a local amateur radio club to provide communications. The result was that the extremely efficient controller of the special net organized for the event--an Ottawa housewife--with the aid of the forty or so mobile amateur stations stepped in and literally ran the affair to a successful conclusion 20 hours later. In addition to supplying communications, the combined experience of the amateurs and the administrative "know-how" of many of them was an important factor in the event's success.

While amateur radio is by its nature an individual hobby, over the years it has become organized on various levels. Most cities have one or more local clubs which vary in size from a dozen to two or three hundred members. The provinces have societies which have either a corporate membership formed of clubs or individual amateurs or a combination of both.

A national organization to serve our 12,000 licensed amateurs was finally started in Canada in 1967. This is the Canadian Amateur Radio Federation Inc. which is a federation of provincial societies, which form its corporate voting members. Provision has recently been made to permit associate memberships by individuals. This allows individual amateurs who wish to directly support the Federation to do so and to obtain timely information provided by the new CARF national publication, The Canadian Amateur which is published ten months of the year. In turn the individual, having timely and accurate information can make his opinions and wishes known to his provincial society or directly to the Federation.

The Federation's officers are elected annually by delegates from its member societies across Canada. The Federation is, by the terms of its federal charter of incorporation, (which was approved by the Department of Communications) officially recognized as the

"...liaison and advisory agency between its members and the Ministry of the Canadian government concerned with issuing licenses performing an Amateur Experimental Service."

The Federation has through its organization and its publication, the Canadian Amateur, the means of getting timely information to Canadian amateurs and of obtaining feedback from provincial societies and individual amateurs.

Its prime interest and its operations are aimed at representing the Canadian Amateur to government. Its financial support is based on contributions from its corporate members which, from their respective provincial society's coffers, allot 25 cents per member to CARF. The individual associate membership designed for non-affiliated clubs and individual amateurs is a further source of income.

Another, but foreign, amateur organization of an entirely different nature also operates in Canada but in a different area of amateur activity. This is the American Radio Relay League (ARRL). The League activities are operations-oriented and are involved with the operation of national and international formal traffic nets on the amateur frequencies. The efficiency of its formal traffic nets in Canada is well-known to Canadian amateurs.

Shortly after World War I, the League, at the request of some Canadian amateurs, extended its operations to Canada by forming a Canadian Division of the American Radio Relay League to operate until a viable Canadian national organization was evolved. This branch of the American Radio Relay League is on an equal status with the other domestic Divisions of the ARRL in the U.S. and its Director reports to the ARRL Board in the U.S. The League is supported by the revenue from a national U.S. amateur magazine known as "QST".

Thus we have at present two organizations in Canada--one Canadian and one foreign, fulfilling two different functions in the amateur world. The Canadian Amateur Radio Federation Inc. with its information dissemination and gathering capability,

its annual democratically elected officers and officially recognized status with the Department of Communication is as yet concerned mainly with the administrative and legislative problems of amateur radio and dealing on a recognized official basis, with the Department of Communications, at all levels, in the matter of regulations, such as those concerning licencing, frequencies. interference and procedures.

The American Radio Relay League in Canada with its formal traffic nets and operations manager who reports to League officers in the United States sponsors the traffic side of amateur activities in Canada.

The Canadian Amateur Radio Federation and the American Radio Relay League branch in Canada can and do consult and co-operate on some matters of mutual interest, but more and more Canadian amateurs are becoming convinced that only the Federation, as the only completely Canadian national and democratic organization should represent them to government even though they individually may for different ends and reasons, support both the Canadian and American organizations.

If you have not already been involved or talked with representatives of the amateur service in your province and are convinced by what you may hear and see today that amateur radio has a place in emergency operations either in "approved" municipal or provincial plans or an ad hoc basis, you will find the CARF representative or an officer of your provincial amateur radio society ready to discuss amateur radio involvement in your plans and to offer you every assistance possible.



canadian amateur radio federation inc.



P. O. BOX 356
KINGSTON, ONTARIO

March 1973

THE CANADIAN AMATEUR RADIO FEDERATION INC.--A SHORT HISTORY

The Canadian Amateur Radio Federation was founded in September, 1967, and federally incorporated with stated objectives and a formal by-law in May, 1972.

The Federation was conceived as an association of provincial Amateur societies that would act for and represent them on the national level, act as a co-ordinating body and, in general, be a source of information of Amateur activities and affairs on all levels.

Initially, temporary officers were appointed to solicit membership from the provincial societies. A meeting of members was held in late 1968 at which a constitution governing administration was adopted. Costs of administration, including financing necessary to hold an annual meeting, postage, stationery, etc., were determined and the strength and finances available to each provincial body were determined. Methods of financing CARF and voting powers of member societies were discussed and, at the request of the Radio Society of Ontario, Inc., the principle of one vote per Federation member and dues based on a provincial society's membership were adopted (25¢/member/year) and have remained in force to this day.

The request of the R.S.O. deserves much credit as it means that they would be paying almost half the cost of financing CARF but would have no greater voting power than any other member. It should also be noted that, in 1969, when it became apparent that administration of the affairs of the Federation was almost non-existent, the executive of the R.S.O., with the concurrence of the other provincial members, assumed the business management of CARF with the President, Secretary and Treasurer of RSO filling these positions in the Federation...this arrangement lasted until the annual meeting in May, 1971.

At that time Officers were elected and appointed and an Executive formed and these officials, during their term of office, succeeded in obtaining a federal Charter for the Federation as "a body corporate and politic in accordance with the provisions of the Canada Corporations Act," dated 16 May, 1972. This was an important step as it gave the Federation a legal entity with certain stated objectives that were agreed to by the federal government.

The Federation as represented by its officers is directed by, and answers to, its provincial members through the system of provincial delegates appointed by the member societies as their representatives. These delegates elect, annually, the Board of Directors who then elect and appoint the officers and executive and who supervise the management of affairs. In all matters concerning the well-being of its members, the Federation is committed to a policy of "consultation prior to action" with each member given a full say on representations, etc., made. Also, where there is an element of disagreement among the members, the representation made contains the full details of opinions pro and con to assist the authorities in their deliberations. This has resulted in a very favourable attitude towards the Federation as we do show proof of backing and evidence of democratic consultation. The Federation is also committed to informing non-member societies of proposals to be made and to request their comment.

Attached is a chart showing the organization of CARF. There are seven directors, one of which is elected as president, three appointed as area directors and one as director-at-large, each with certain responsibilities. The directors, officers and chairmen of the standing committees form an executive committee to handle the day-to-day business management of the federation. This executive answers to the board for its actions.

Each provincial member appoints a delegate to represent it at the CARF meetings with full power of representation thereto. In several cases a provincial member has appointed an alternate delegate who resides close to Ottawa to act as the delegate where that person can not attend meetings and this arrangement has worked very satisfactorily.

CARF is nothing more than the national arm of the provincial member...in turn, the provincial member represents CARF on the provincial level.

In 1969 the Federation commenced the publishing of monthly Newsletters which were circulated to the members and other organizations as a source of information of Canadian Amateur activities. Circulation of this publication grew substantially with numerous requests for individual copies. As well, many Amateurs wanted some manner in which they could support, as individuals, the activities of the Federation. This resulted in the creation of associate membership for individual amateurs in CARF and the publishing of a monthly news publication, "THE CANADIAN AMATEUR." This has been well received and has resulted in a resurgence of interest in the provincial member by the individual as the provincial member has the voting power in determining the course of action to be taken by the Federation. The individual can now receive timely and topical information on the Amateur Experimental Service, express his comment to the provincial member and aid it to guide the Federation. It is stressed that "THE CANADIAN AMATEUR" is a news publication, not a magazine, its primary aim being to supply information to the amateur.

The Federation has, on occasion, been accused of being "anti-ARRL" and "a group of misguided fanatics trying to run amateur radio." By the very nature of CARF's organization, the latter cannot be true. As to the other, it is a matter of record that the Federation has scrupulously published what information has been made available re the League, has criticized it when CARF felt it was not acting in the best interests of the Amateurs of Canada and has complimented it for actions that were. The former CARF Newsletters and now "THE CANADIAN AMATEUR" and the CARF News Service bulletins are the only CARF publications and the Federation has never sanctioned comment made by other publications purporting to speak on our behalf. The Federation can not control editorial and other comment that appears in other publications and in several cases has sent strong letters of protest to the people concerned regarding their misrepresentation of CARF, the ARRL and non-member provincial organizations.

In 1971, an arrangement was made with the editor of VE NEWS so that this publication would carry the complete CARF Newsletter thus giving a much wider circulation than was possible with the facilities then available to the Federation. Editorial comment and other articles in VE NEWS were to be divorced from the CARF content and both sides reserved the right to stop publication of the Newsletters if the content was found to be detrimental to the "image" of either. This worked very satisfactorily and, when THE CANADIAN AMATEUR was published, the editor of VE NEWS stopped publication of that magazine and now writes an independent column for the CARF Editor. In addition, the Federation, through its CARF News Service is furnishing information bulletins to editors of provincial amateur publications.

The Canadian Amateur Radio Federation Inc., as reflected by its federal government charter, is the national amateur organization of Canada. As the President of ARRL has stated - "There is a need for strong national organizations in every country" - and our full strength and voice on national and international amateur affairs can only be realised by 100% membership of the provincial societies. The responsibility of CARF is to show leadership to the Amateurs of Canada and the responsibility of the provincial members is to guide the Federation. One province alone can achieve little; ten provinces banded together can achieve results. And, to overcome the many problems that will confront amateur radio in the years to come, the Amateurs of Canada need this strength and guidance for the continued well-being of the Amateur Experimental Service.

Art Blick, VE3AHU
President.

CANADIAN AMATEUR RADIO FEDERATION INC.

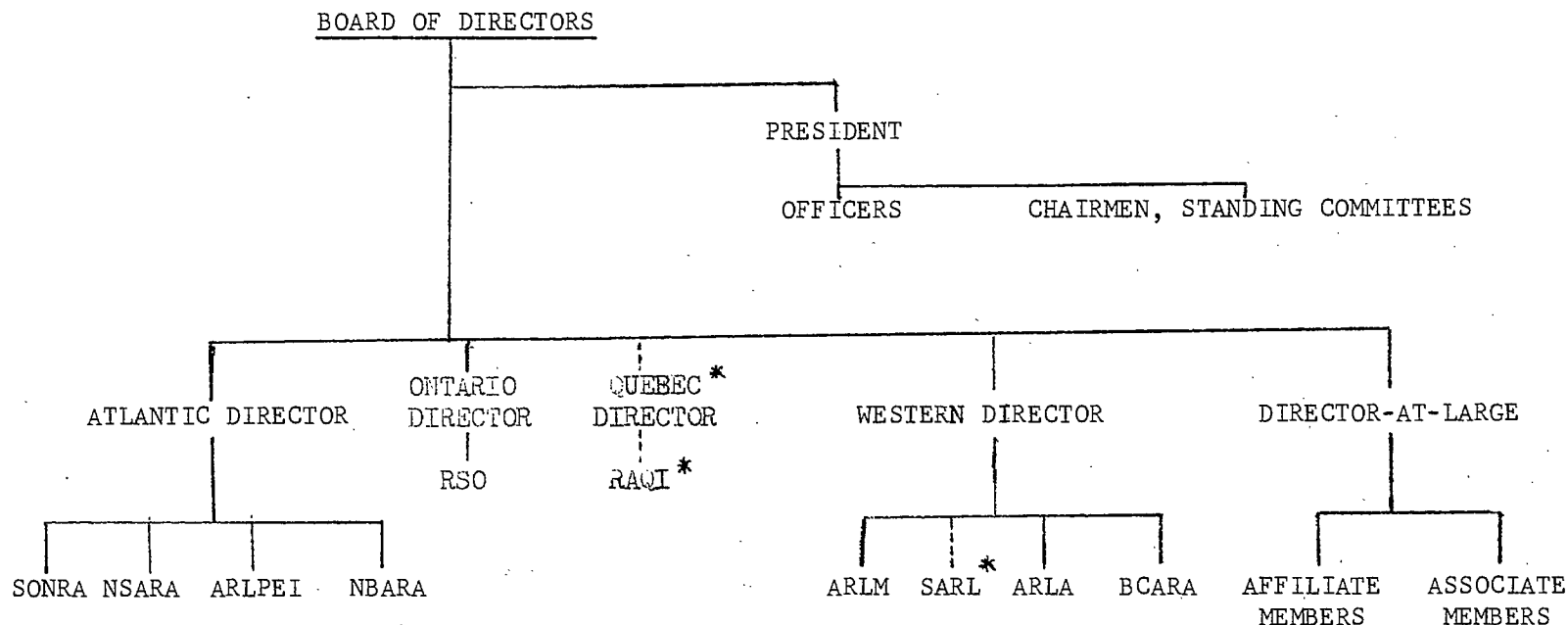

NOTE 1: Provincial members appoint Delegate to represent them; Delegates convene annually and elect Board of Directors.

2: Board of Directors convene annually to elect a President and appoint the Officers and Chairmen of Standing Committees.

3: Board of Directors may appoint an Executive Committee to manage the day-to-day affairs of the Federation.

* Provision is made for RAQI and SARI, to become corporate members of the Federation if they so wish.

IN THE HOUSE OF REPRESENTATIVES

JANUARY 31, 1973

Mr. TEAGUE of California (for himself and Mr. BENNETT) introduced the following bill; which was referred to the Committee on Interstate and Foreign Commerce

A BILL

To amend the Communications Act of 1934 to require that radio and television receivers meet certain technical standards for filtering out interference.

1 *Be it enacted by the Senate and House of Representa-*
2 *tives of the United States of America in Congress assembled,*
3 That section 303 (s) of the Communications Act of 1934 is
4 amended by inserting “(1)” after “(s)” and by adding at
5 the end thereof the following:

6 “(2) Have authority to require that apparatus designed
7 to receive broadcasts comply with standards of the Commis-
8 sion under this paragraph (2), when such apparatus is
9 shipped in interstate commerce, or is imported from any
1 foreign country into the United States, for sale or resale
2 to the public. Standards under this paragraph shall be pre-
3 scribed by rule for the purpose of requiring the filtering out
4 of interference. Such standards shall include a requirement
5 that all interference from any amateur station, and any citi-
6 zens radio service station, operating on its assigned frequency,
7 be filtered out.”



canadian amateur radio federation inc.



P. O. BOX 356
KINGSTON, ONTARIO
10 July 1973

MESSAGE FORMS

1. One problem encountered when operators of the Amateur Experimental Service are used as part of the EMO Communication system is that the normal message format used by the Amateurs - the so-called ARRL form - differs in several respects with the form used by EMO.
2. The majority of Restricted Radio Operators used in the EMO system are not highly qualified and are familiar with the EMO message form only. Any divergence from this form leads to confusion, request for repetition and slows down the flow of traffic.
3. It is therefore recommended that the Amateurs be supplied with, and be encouraged to use, a message format similar to that used by EMO. For good public relations, this Amateur message form should be distinctly labelled as such. A suggested format is attached.
4. It is suggested that the message form be produced in pads of 50 and supplied to the Amateur provincial organizations and down to the municipal EMO level in quantity together with a procedure to be followed for its use. (att'd.)
5. The publication and use of such a form was discussed at the recently held Working Group on Emergency Communications held at CEMO College with the Canadian Amateur Radio Federation Inc to submit a suitable format, etc, for consideration.
6. Previous to the conference, the use of such a format was discussed with the Director, Canadian Division, American Radio Relay League, Inc and found favour for use within Canada. However, if Amateur messages originating in Canada are forwarded through the ARRL (USA) national traffic system, it will be necessary to change the format used to the accepted ARRL type. This would present little problem to the trained Amateur operators concerned.

Arthur E. Blick, VE3 AHU

MESSAGE FORMS

All messages consist of several parts that should be transmitted in the following order:

- | | |
|---------------------------------------|---------------------------------|
| a) Call signs | CJW 612 from CJW 637 |
| b) Station transmission number | My number 7 |
| c) No. of words in text | Number of groups 37
Break |
| d) Date - time group | Date - time 061942 |
| e) Address from | From Mayor Kingston |
| f) Address to | To Reeve Kingston Township |
| g) Originators Number (filing number) | Originators number K23
Break |
| h) Text | Supply 14 _____
Break |
| i) Signature | Signed: Jones

Over. |

1. Items a) to c) known as the preamble are filled in by the operator.
2. Originator of message fills in items a) to i) inclusive.
3. The operators will fill in, at the bottom of the message form, the time message received, either from originator or from other station, in "R" spaces: and time message is delivered, either to recipient or to another station, in "D" spaces.
4. No. of words in text includes all groups in item d) to i) inclusive.
5. The station operator will number all messages consecutively as received from their originators, to provide a check on the continuity of service so that messages will not become lost. A new series is used each day, with the day starting at midnight.



CANADIAN AMATEUR RADIO MESSAGE FORM

Station of Origin	Message No.	Priority	Text Word Count	Date-Time-Month of Origin

From/

Telephone

To/

Telephone

Received From	Date-Time-Month	Delivered To:	Date-Time-Month

THIS MESSAGE IS HANDLED WITHOUT CHARGE BY AMATEUR RADIO OPERATORS

THE EFFECTS OF THE ELECTRO-MAGNETIC PULSE
GENERATED BY NUCLEAR WEAPONS

Because emergency planning embraces the whole spectrum of crises which could face a community or nation, planners must still include preparations for such a disaster.

The effect of nuclear weaponry known as, "electro-magnetic pulse in telecommunications equipment" was the subject of a talk at the Communications Planners' Conference at Arnprior, in February, 1973, and the following quotations are of interest to them. These are from a U.S. publication, "Attack Environment Manual", published by the U.S. Defense Civil Preparedness Agency (formerly Office of Civil Defense), Chapter 4, "What the Planner Needs to Know About Electro-Magnetic Pulse". They are reproduced here because of the references to survivability of amateur radio equipment.

"Experiments have shown that civil defense radiation detection equipment is not susceptible to direct damage nor are hand-held Citizens Band walkie-talkies or FM radio receivers. Generally, the relative vulnerability of components has been determined, with transistorized equipment most susceptible."

"It has been found that communications equipment employing bipolar transistors with self-contained batteries and loop antennas are not susceptible to direct EMP damage. Similar equipment with stick antennas up to 40 inches long can be operated safely. Equipment using field-effect transistors may suffer damage if connected to an antenna exceeding 30 inches in length."

"The general implication of these results is that mobile communications equipment is relatively survivable while radio base stations are vulnerable unless protected against EMP."

"Mobile units in these systems have battery power supplies and relatively short antennas. They are most likely to remain operable. The implication for emergency planners is that arrangements to permit mobile-to-mobile communications will be important as an alternative in the event of loss of a base station."

" long-distance communications in the high-frequency (HF) band can be interrupted for several hours since they depend on the bending of radio waves back toward the earth for distant communication. Short-range communications within a city or county are unlikely to be affected by radio blackout. The current trend toward use of very high-frequency (VHF) and ultra-high-frequency (UHF) bands for public safety and amateur broadcasts decreases the likelihood of blackout of these communications."

"The "20-meter" and "40-meter" bands are still popular for long-distance amateur communications, however. Since radio blackout can be confused with EMP damage to equipment, the planner should take account of its existence. Radio blackout will not cause damage to equipment, merely interfering temporarily with receipt of radio transmissions. This is unlikely to be of serious consequence to emergency operations."

