



ARCHIVED - Archiving Content

Archived Content

Information identified as archived is provided for reference, research or recordkeeping purposes. It is not subject to the Government of Canada Web Standards and has not been altered or updated since it was archived. Please contact us to request a format other than those available.

ARCHIVÉE - Contenu archivé

Contenu archivé

L'information dont il est indiqué qu'elle est archivée est fournie à des fins de référence, de recherche ou de tenue de documents. Elle n'est pas assujettie aux normes Web du gouvernement du Canada et elle n'a pas été modifiée ou mise à jour depuis son archivage. Pour obtenir cette information dans un autre format, veuillez communiquer avec nous.

This document is archival in nature and is intended for those who wish to consult archival documents made available from the collection of Public Safety Canada.

Some of these documents are available in only one official language. Translation, to be provided by Public Safety Canada, is available upon request.

Le présent document a une valeur archivistique et fait partie des documents d'archives rendus disponibles par Sécurité publique Canada à ceux qui souhaitent consulter ces documents issus de sa collection.

Certains de ces documents ne sont disponibles que dans une langue officielle. Sécurité publique Canada fournira une traduction sur demande.

CPRC

CANADIAN POLICE RESEARCH CENTRE



CCRP

CENTRE CANADIEN DE RECHERCHES POLICIÈRES

TR-03-92
Formal Test Report for Radiation Hazard
Measurements in Police Vehicles
"Hotspot Study"

D. Zanette and D. Scribailo
MPB Technologies

TECHNICAL REPORT

March 1992

NOTE: Further information
about this report can be
obtained by calling the
CPRC information number
(613) 998-6342

Copyright of this document does not belong to the Crown.
Proper authorization must be obtained from the author for
any intended use.

Les droits d'auteur du présent document n'appartiennent
pas à l'État. Toute utilisation du contenu du présent
document doit être approuvée préalablement par l'auteur.

Executive Summary

The use of police traffic radar units has been recently addressed as to police officer safety. The CPRC contracted a further study to determine if there was any danger of operating a radar unit inside a police car. Although this procedure is not standard practice, there have been occasions where this had been observed especially during the winter months.

Two full-size cars, a 1991 Ford LTD and a 1992 Chevrolet Caprice were used in the study. The purpose of the study was to determine if there were any multiplying or amplifying factors that would increase the power of the units in the patrol car. The study investigated two positions - position 1 - forward through the front windshield and position 2 - attached to the door pillar (driver's side) facing through the back windshield. In the second position two orientations were investigated - straight through the back window and pointed downward at the rear window deck.

The conclusion of the study was that there was no amplification of the radar power in the patrol cars.

Customer No.: 91-1537/4502

MPBT No.: 1139

Formal Test Report
for Radiation Hazard
Measurements of
Police Vehicles

D. Zanette
D. Scribailo .

Prepared for:

CANADIAN POLICE RESEARCH CENTRE
Building M-50
NRC, Montreal Road
Ottawa, Ontario
K1A 0R6

Prepared by:

MPB Technologies Inc.
Building M-50, NRC
Montreal Road
Ottawa, Ontario
K1A 0R6

March 30, 1992
C13-R-39

Dave G. Scribailo
Manager
Electromagnetic Services
Electromagnetics Division

TABLE OF CONTENTS

1.0	Documentation REPORT
1.1	Scope
1.2	Perceptions
1.3	Rationale
1.4	Exposure Standards
1.5	Recommendations
1.6	Summary
2.0	TEST REPORT OF RF MEASUREMENTS
2.0.1	Applicable Documents
2.1	Calibration of Microwave Speed Monitoring Equipment
2.1.1	Scope
2.1.2	Test Conclusion
2.1.3	Radar Measurement Methodology
2.1.4	Emitted Power Levels of the Microwave Speed Monitoring Equipment Measured at Two Inches
2.2	RF Measurements Within the Police Cruisers
2.2.1	Scope
2.2.2	Applicability
2.2.3	RF Power Level Measurements Within the Two Sample Police Cruisers
2.2.4	Observations
2.2.5	Test Report Data

APPENDICES

- Appendix A: Test Equipment Report
- Appendix B: Bibliography
- Appendix C: Radar Safety Bibliography (CPRC)
- Appendix D: Law Enforcement News - Traffic Hazard
- Appendix E: Traffic Radar: Human Experimentation Without Informed Consent
- Appendix F: Proposed Revision of the Canadian Recommendations on Radiofrequency-Exposure Protection
- Appendix G: Nonionizing Radiation and Speed Monitoring Devices (Staff Study)
- Appendix H: Testing of Police Traffic Radar Device - Volume I (Performance Test Center)
- Appendix I: Testing of Police Traffic Radar Device - Volume II (Performance Test Center)
- Appendix J: Traffic Radar Power Densities: Summary of Findings (IPTM)
- Appendix K: Radiation Characteristics of Traffic Radar Systems - Technical Note (EPA)
- Appendix L: Non-Ionizing Radiation (Health and Welfare Canada)
- Appendix M: Power Density Measurements Taken with Narda Model 8316 Hazard Meter (NBS)
- Appendix N: Field Strength Measurements of Speed Measuring Radar Units (NHTSA)
- Appendix O: Safety Code 6 (Health and Welfare Canada)
- Appendix P: Assessment of Radiation Hazard Risks (Bureau of Workers' Compensation)
- Figure 1: Police Cruiser Grid Reference - Top View
- Figure 2: Police Cruiser Grid Reference - Side View
- Figure 3: Police Cruiser Grid Reference - Front View

1.0 DOCUMENTATION REPORT

1.1 SCOPE

The purpose of the text contained herein is not an attempt by MPBT to make any presuppositions on the effects of microwave radiation, but to summarize and present the facts and data compiled in the papers published by various authorities and concerned individuals, as specified in the Bibliography.

1.2 PERCEPTIONS

When researching documentation regarding the effects of human exposure to non-ionizing microwave radiation in the 8-12 GHz and 18-26 GHz bands, an underlying theme emerges.

This theme is the tendency for alarm due to misinformation and the absence of sufficient information on microwave exposure. This is not to say that exposure to microwave energy is or is not detrimental to human tissue.

Articles such as "The Hidden Hazard of Traffic Safety" by Gary Poynter, found in the publication Law Enforcement News, attempts to link cases of police officers with cancer to excessive exposure to microwave energy from microwave speed monitoring equipment. The article also goes on to cite examples of OHEA (Office of Health and Environmental Assessment) and EPA (Environmental Protection Agency) reports warning of the possible hazards of chronic exposure to electromagnetic radiation such as that emitted by microwave speed monitoring equipment.

In the article entitled "Patrol Car Hot Spots", the author states that... "The interior of the patrol vehicle equipped with a traffic radar unit also contributes to the creation of 'hot spots'. The microwave signal from a traffic radar unit bounces around the interior of the vehicle, and where the signals converge can cause a hot spot where the power density is higher than that actually produced by the radar unit itself at peak power."

Another article entitled "A Doctor's Warning" quotes Dr. Milton Zaret (a specialist in radiation-related injuries) as saying... "The practice of using radar speed detectors inside the cab is extremely dangerous. You should be disturbed by the contrary advice apparently given you."

It has also been stated that officers employing microwave speed monitoring equipment are not given proper instruction on safety procedures, such as not to point the microwave beam at the body and not to look directly into the radiating end of the microwave speed monitoring equipment.

The opinion raised in the above statements expresses a growing concern about the actual safety of microwave speed monitoring equipment.

1.3 RATIONALE

Logically, the implementation of a specific standard to insure sufficient safety margins from a particular hazard, would entail a thorough analysis and understanding of the health risks.

In the paper entitled "Proposed Revision of the Canadian Recommendations on Radiofrequency Exposure Protection" by M. A. Stuchly of the Bureau of Radiation and Medical Devices, Health and Welfare Canada, it is stated that... "In development of health protection standards, such as RF exposure limits, various general rules and criteria can be selected. There should be a sufficient data base of adverse effects on human beings and their mechanisms, which permits a quantitative analysis of health risks related to any proposed protection limit."

"Scientific data on adverse effects on humans, including epidemiological investigations, are so sparse and incomplete that they are insufficient for even qualitative hazard assessment. Therefore, RF exposure standards are nearly exclusively based on experimental evidence with animals and complex physical and physiological explorations. Furthermore, inheritance mechanisms are not well understood for many of the effects observed.

"For occupational exposures, a safety factor of approximately 10 was incorporated with reference to what was judged as exposure conditions resulting in a potentially harmful health effect. For the general population, an additional safety factor of 10 was included."

scientific American Magazine states that... "The setting of standards is a surprisingly difficult process. Some hazards of microwave energy, such as burns or heat stress, are well established; effective standards can be set for these. Whether other standards can arise from exposure to low levels of microwave energy is a matter of conjecture, which depends on the interpretation of a large body of often unreliable reports."

1.4

EXPOSURE STANDARDS

Exposure standards found around the world vary typically from 10 mW/cm^2 down to 1 mW/cm^2 , averaged over a period of time.

In the USA, the American National Standards Institute (ANSI) has set a limit of 5 mW/cm^2 averaged over 0.1 hours, or 6 minutes.

In Canada, the Environmental Health Directorate, Health Protection Branch has published a document entitled @@Safety Code 6 - Recommended Safety Procedures for the Installation and Use of Radiofrequency and Microwave Devices in the Frequency Range 10 MHz to 300 GHz". In this document, Section 2.5, page 6, entitled 'Maximum Exposure Level for the General Public' states that... "For whole or partial body exposure or any member of the general public to either continuous or modulated electromagnetic radiation of frequencies in the range 10 MHz to 300 GHz, the following levels must not be exceeded, when averaged over a one-minute period:

- rms electric field strength 60 V/M
- rms magnetic field strength 0.16 V/M
- power density 1 mW/cm^2

In addition to the exposure level standards, Safety Code 6 includes in Section 3 guidelines for 'Responsibility and Personnel'. In this section, Safety Code 6 states that... "The owner of the device or installation emitting the RF/microwave waves is ultimately responsible for radiation safety. The owner is responsible for ensuring that the equipment provided for the responsible user and microwave radiation workers meets all applicable radiation safety standards for that equipment and the safety requirements specified in this Code (Safety Code 6). The owner may delegate this responsibility. How this responsibility is delegated to staff will depend on the size of the organization and the amount of radiation emitting equipment owned. One or more persons must be designated by the owner to carry out the role described below."

Under the sub-heading entitled 'Responsible User' of Safety Code 6, it is stated that... "there must be at least one person, or committee, designated at the responsible user, to undertake responsibility for:

- a) ensuring that assigned equipment is maintained and used correctly by competent personnel;
- b) establishing safe operating procedures for the equipment;
- c) setting radiation safety rules and ensuring that all staff are made aware of them;
- d) ensuring that all microwave radiation workers are aware of the contents of this code;
- e) knowing the exposure levels in the vicinity of the equipment under all conditions of use;
- f) demarcating areas where exposure in excess of the maximum limits can result, and posting warning signs drawing attention to permitted occupancy durations as determined by the recommendations of Section 8.2;
- g) investigating exposures which may be in excess of the maximum levels permitted;
- h) designating staff as microwave radiation workers;
- i) arranging for the medical examination of "over-exposed workers" as deemed appropriate;
- j) recording levels and duration of exposure for persons who have been exposed in excess of the maximum limits: and
- k) ensuring that appropriate radiation surveys or monitoring are performed when and as required."

Under the heading 'Safety Officer' (Section 3.3), the Code states that... "A safety officer may be delegated some of the responsibilities of the responsible user. The extent and nature of these will depend on the size of the organization and the number of devices. In general, the Safety Officer provides technical support in the planning, installation of, and use of RF and Microwave devices."

When reviewing paper such as:

'Report on Traffic Radar Microwave Exposure' by A. Trottier MD., Director Health Services, **CPRC**

'Staff Study, Non-Ionizing Radiation and **Speed** Monitoring Devices' (Batelle Study) by Colonel Thomas W. Rice, Superintendent OSHP, and Charles D. Shipley, Director, Department of Highway Safety

'Traffic Radar Power Densities: Summary of Findings' (April 19, 1991) by Robert Bradley, Institute of Police Technology and Management

the recommendations made for safety procedures when using microwave speed monitoring equipment, are representative of the procedures recommended by MPBT.

RECOMMENDATIONS

MPBT makes the following recommendations, to enhance safety for owners of microwave speed monitoring equipment.

- a) Microwave speed monitoring equipment being considered for acquisition should be certified.
- b) Microwave speed monitoring equipment must be inspected for proper operation and power output levels on a regular basis. The power output levels would be compared to the Canadian Safety Code 6 specification of 1 mW/cm^2 . Equipment found to be out of specification should be removed from service.
- c) Appropriate instruction should be given on the proper use of, and safety aspects of microwave speed monitoring equipment.

The following instructions should be included when training users on the proper handling of microwave speed monitoring equipment:

- i) When handling the microwave speed monitoring equipment, avoid pointing it at any occupants in the vehicle.
- ii) When the microwave speed monitoring equipment is operating, insure that it is pointing through the window.
- iii) When the microwave speed monitoring equipment is not in use for speed measurements, turn it off. This will reduce the overall exposure period.

SUMMARY

Although several papers have been written on microwave speed monitoring equipment and their radiated fields, there still appears to be a lack of consensus on the effects that low level microwave energy from this equipment has on humans.

When measurements, taken by MPBT, of microwave RF levels inside two police cruisers equipped with microwave speed monitoring equipment, were compared to measurements found in the following reports:

- 1) "Institute of Police Technology and Management", April 23, 1991;
- 2) "Field Strength Measurements of Speed Measuring Radar Units", by Law Enforcement Standards Laboratory, US Department of Commerce, National Bureau of Standards, 1981;
- 3) "Testing of Police Traffic Radar Devices to the Model Performance Specifications for Police Traffic Radar Devices - April 1984", by Performance Test Center (PTC), Research and Development Division, International Association of Chiefs of Police under National Bureau of Standards
- 4) "Batelle Study - December 13, 1990", by Dr. James Wasil, Technology and Science Advisor, Division of Safety and Hygiene, Bureau of Workers Compensation, Columbus, Ohio;
- 5) "Ohio State Highway Patrol Planning and Analysis", March 1991.

MPBT's data showed very good agreement.

In the final analysis, it does not appear to be a matter of microwave speed monitoring equipment not conforming to regulations but rather how microwave RF levels, complying with regulations, are affecting the equipment user.

2.0

TEST REPORT OF RF MEASUREMENTS

2.0.1 APPLICABLE DOCUMENTS

The following documents, or parts thereof, may be applicable to this Test Report:

ANSI C63.5	"For Electromagnetic Compatibility - Radiated Emissions Measurements in Electromagnetic Interference (EMI) Control - Calibration of Antennas"
NBS Tech. Note 1309	"NBS Calibration Procedures for Horizontal Dipole Antennas"
NBS Tech. Note 1099	"Electromagnetic Compatibility and Interference Metrology"
NBS	"Calibration and Meaning of Antenna Factor and Gain for EMI Antennas"
IEEE	"Properly Applied Antenna Factors"
MPBT	"Summary of Visit to NIST"
SAE-ARP 985	"Broadband Electromagnetic Interference Measurement Antennas: Standard Calibration Requirements and Methods"

2.1 CALIBRATION OF MICROWAVE SPEED MONITORING
EQUIPMENT

2.1.1 SCOPE

This Test Report, submitted by MPBT, establishes the test procedures and associated data for Radiation Hazards testing of microwave speed monitoring equipment manufactured by "Tribar Industries" and "Kustom Signals Inc". All measurements were taken at a distance of two inches from the radome.

2.1.2 TEST CONCLUSION

All data collected to date by MPBT indicates that of the numerous microwave speed monitoring equipment measured, all units produced results that were well within the Safety Limits specified by the Health and Safety Code 6.

2.1.3 RADAR MEASUREMENT METHODOLOGY

The Safety Code 6 of National Health and Welfare of Canada states that the "General Public (those individuals that are not microwave radiation workers) shall not be exposed to power density levels greater than 1 mW/cm² averaged over a 1-minute period in the range of frequencies between 10 MHz and 300 GHz.

The microwave speed monitoring equipment used (Tribar Industries, Serial Number 13301; and Kustom Signals Inc., Serial Number 5540001) operate in the continuous-wave mode (CW), and, when measured for RF output, have been found to radiate below the specified 1 mW/cm² limit.

GUN TYPE	MEASUREMENT DISTANCE TO HORN	mW/cm ²
Tribar	2 inches	0.69
Kustom Signals	2 inches	0.80

2.1.4 EMITTED POWER LEVELS OF THE MICROWAVE SPEED MONITORING EQUIPMENT MEASURED AT TWO INCHES

The radiation levels at 10.5 GHz and 24.15 GHz were measured at two inches from the horn covers of the microwave speed monitoring equipment.

For the 10.5 GHz frequency, a small X-band linear horn (2.5 cm by 2.25 cm mouth) was used to receive the radiated energy. For the 24.15 GHz frequency, a small K-band horn (1.5 cm by 2.0 cm mouth) was used to receive the radiated energy.

The 10.5 GHz horn was first calibrated on the Hewlett-Packard 8510 Network Analyzer for minimum VSWR; then, using the "Three-Antenna Method"¹, the Gain was determined to be nine (9) dB.

The expected power from the horn in a one mW/cm^2 field was determined by the following formula:

$$Pr = \frac{F \cdot G \cdot \lambda^2}{4 \pi}$$

Pr = Power Received

F = Field mW/cm^2 at the Horn Focus

G = Gain of Horn = 9 dB or 7.9

λ = Wavelength at 10.5 GHz = 2.84 cm

Therefore,

$$Pr = \frac{1 \text{ mW/cm}^2 \cdot 7.9 \cdot (2.849 \text{ cm})^2}{4 \pi} = 5.1 \text{ mW}$$

A calibrated source of 10.5 GHz was set to 5.1 mW and fed into a receiver. The receiver signal was recorded and compared to the signals from the receiving horn, placed two inches from the microwave speed monitoring equipment. Since the unit transmits circularly polarized signals, the vertical and horizontal components were added to obtain the Total Power.

*1 - Three Antenna Method, ARP-958, ANSI-C63.5

The 24.15 GHz horn was first calibrated using the Hewlett-Packard 415E SWR Meter for minimum VSWR; then, using the "Gain Measurement by Comparison Method"^{*2}, the horn gain was determined to be 18 dB.

The expected power from the horn in a 1 mW/cm² field, F, was evaluated using the following formula:

$$Pr = \frac{F \cdot G \cdot \lambda^2}{4\pi}$$

where G is the gain of the horn, and λ is the wavelength of the emitted radiation.

For the 10.5 GHz horn, this yields:

Eq. (1):

$$Pr = \frac{1 \text{ mW/cm}^2 \cdot 63.09 \cdot (1.24 \text{ cm})^2}{4\pi} = 7.7 \text{ mW}$$

Using this reference, Eq. (1) may be rearranged to give:

$$F = \frac{4\pi \cdot Pr}{G (\lambda^2)}$$

at the position of the measuring horn.

The RF signal radiated by the 24.15 GHz microwave speed monitoring equipment is also circularly polarized; thus, the Total Power is composed of the horizontal and vertical components added together.

*2 - "Antennas" by L. V. Blake, 1984, Library of Congress Catalog Number: 84-04513, originally published by John Wiley & Sons 1966

2.2 RF MEASUREMENTS WITHIN THE POLICE CRUISERS

2.2.1 SCOPE

This Test Report, submitted by MPBT, establishes the test methods and procedures for conducting Radiated Emissions in sample Police Cruisers to locate the zones of maximum microwave radiation levels.

2.2.2 APPLICABILITY

All test procedures, limits, results and observations defined by this document apply to the radiation hazard testing the Tribar Industries and Kustom Signals Inc. Radar Speed Guns, located within a Ford Crown Victoria and a Caprice Classic.

2.2.3 RF POWER LEVEL MEASUREMENTS WITHIN THE TWO SAMPLE POLICE CRUISERS

Measurements of the ambient RF levels within the police cruisers were systematically taken, using a pre-defined "X-Y-Z Grid Pattern" for positional reference.

Measurements were started at the origin 0-0-0 (refer to Figure 1) and proceeded at the grid increments of the "X-Y-Z Grid".

Each point was scanned through three axes, and at 0° and 90° of horn polarization--thus covering all possible angles about each grid point.

Any anomalies that appeared, or the highest signal level observed, was recorded on the data sheet, with an X-Y-Z coordinate.

To ensure complete coverage of the vehicle interior, scanning with the horn was also conducted in all spaces between grid coordinates.

Any signals found having significant amplitudes were associated with the nearest X-Y-Z grid intersection.

Scanning was also concentrated in the space that would be occupied by the driver.

Side-lobe emissions from the microwave speed monitoring equipment were also scanned at each unit position.

It should be noted that RF absorbing material was placed in front of and behind each police vehicle, to absorb the radiated RF energy from the microwave speed monitoring equipment.. The purpose of this procedure was to reduce any reflections of RF energy back into the vehicle, thus causing any unrealistically high RF energy measurements.

2.2.4 OBSERVATIONS

On analysis of all the data acquired, it was found that although RF energy is present throughout the entire interior of each vehicle, the levels of the RF energy were well below the specified safety limit of one mW/cm^2 .

The most significant RF energy levels were observed when the measuring horns were in line with, and pointing at, the microwave speed monitoring equipment's output horn. These energy levels were also well below the specified limits.

2 . 2 . 5

TEST REPORT DATA - Available on request (54 pages)

TEST EQUIPMENT REPORT

TEST COMP./PART:

Page 1 of 11

TEST ENGINEER:

DATE:

D. ZANETTE

OTTAWA

FACILITY:

RADAR MEASUREMENTS

POLICE CRUISER MEASUREMENTS

MANUFACTURER	MODEL NO.	DESCRIPTION	SERIAL NO.	CAL. DATE	RECAL. DATE	
Hewlett-Packard	HP85668	Spectrum Analyzer	281646945 2747A05484	13/06/91	13/06/92	
Advantest	R3261A	Spectrum Analyzer	01720078	24/01/92	24/01/93	
Hewlett-Packard	8510A	Network Analyzer	00594	05/06/91	05/06/92	
Tektronix	466	Storage Oscilloscope	NRC 601-0496			
Tektronix	485	Oscilloscope	B144936	N/A	N/A	
Solar	7021-1	Phase Shift Network	860886	03/01/92	03/01/93	
Hewlett-Packard	9000-300	Computer	GP10 98622A	N/A	N/A	

APPENDIX A

CUSTOMER NO.:

91-1537/4502

MPBT NO.:

1139

TEST EQUIPMENT REPORT

TEST COMP./PART:		OTTAWA				Page 9 of 11
TEST ENGINEER:		D. ZANETTE				DATE:
FACILITY:		OTTAWA				
MANUFACTURER	MODEL NO.	DESCRIPTION	SERIAL NO.	CAL. DATE	RECAL. DATE	POLICE CRUISER MEASUREMENTS
Fluke	83	Multimeter	51900396	09/01/92	09/01/93	
Fluke	8840A	Multimeter	3538007	22/10/91	22/10/92	
Hewlett-Packard	436A	Power Meter	2031U01714	06/01/92	06/01/93	✓
Hewlett-Packard	8482A	Power Sensor	2349A07462	06/01/92	06/01/93	✓
Hewlett-Packard	3478A	Multimeter	2301A19180	N/A	N/A	
Fluke	8020B	Digital Multimeter	2810144A	N/A	N/A	
Hewlett-Packard	6269B	Power Supply 50-amp, 50 VDC	2543A13008	N/A	N/A	
Harrison Laboratories	505A	Power Supply 0 - 72 VDC		N/A	N/A	
MPBT	DO-160B	Power Supply 0 - 110 VDC		N/A	N/A	
Date	RH 250	Resistor 5-ohm, 250-watt		N/A	N/A	
CUSTOMER NO.: 91-1537/4502						MPBT NO.: 1139

1) "R

APPENDIX B

2) "
F

on Radio

3) **"The Bidden Hazard of Traffic Safety"**

G. Poynter
Law Enforcement News
Vol. XVI, No. 324
November 15, 1990

4) **"Traffic Radar - Human Experimentation Without Informed Consent"**

G. Poynter
1990

5) **"Staff Study - Non-Ionizing Radiation and Speed Monitoring Devices"**

Ohio State Highway Patrol
Planning and Analysis (Batelle Study)
March 1991

6) **"Testing Of Police Traffic Radar Devices - Test Center, Volume I, Test Program Summary Performance"**

International Association of Chiefs of Police
Development Division
April 1984

7) **"Testing of Police Traffic Radar Devices - Volume II, Test Data, Performance Test Center"**

International Association of Chiefs of Police
Research and Development Division
May 1984

- 8) "Traffic Radar Power Densities: Summary of Findings"
Institute of Police Technology and Management
University of North Florida
Jacksonville, Florida
April 19, 1991
- 9) "Technical Note: Radiation Characteristics of Traffic Radar Systems"
United States Environmental Protection Agency
March 1976
- 10) "Non-Ionizing Radiation"
Health and Welfare Canada
1985
- 11) "Field Strength Measurements of Speed Measuring Radar Units - Interim Report"
National Bureau of Standards
June 1981
- 12) "Safety Code 6 - Recommended Safety Procedures for the Installation and Use of Radiofrequency and Microwave Devices in the Frequency Range 10 MHz-300GHz"
Environmental Health Directorate
Health Protection Branch
Minister of National Health and Welfare
February 1979
- 13) "Antennas"
L.V. Blake
1984
- 14) "NBS Technical Note 1319: Generation of Standard Electromagnetic Fields in a TEM Cell"
M. Kanda; R. David Orr
- 15) "Measurement of Antenna Factors with a TEM Cell"
S.C. Kashyap

- 16) "The Equivalent Capacitance Substitution Method"
E.C. Jordan
"EM Waves & Radiating System"
p. 483
Navship 94810
"The Radio Frequency Interference Meter"
University of Pennsylvania
1962
- 17) "The Institute of Electrical and Electronic Engineers"
Section 2.2.2.3
- 18) "NBS Technical Note 1309: Calibration Procedures for
Horizontal Dipole Antennas (25 to 1000 MHz)"
D.G. Camell; E.B. Larsen; J.E. Cruz
- 19) "ANSI C63.5: American National Standards for
Electromagnetic Compatibility, Radiated Emission Measurement
in EMI, Calibration of Antennas"
1988
- 20) "SAE-ARP 958: Broadband Electromagnetic Interference
Measurement Antennas: Standard Calibration Requirements and
Methods"
- 21) "Test Report for Radiation Measurements on Police Traffic
Radar Speed Detectors - Ottawa Police"
L. Allan
MPB Technologies Inc., Ottawa
November 26, 1991
- 22) "Standing Offer for Radiation Measurements on Police Traffic
Radar Speed Detectors"
Canadian Police Research Centre and MPB Technologies
Inc.
Ottawa
January 1992

FIGURE 1 - POLICE CRUISER X,Y,Z GRID REFERENCE .
GRID SPACING IS 1 FOOT .

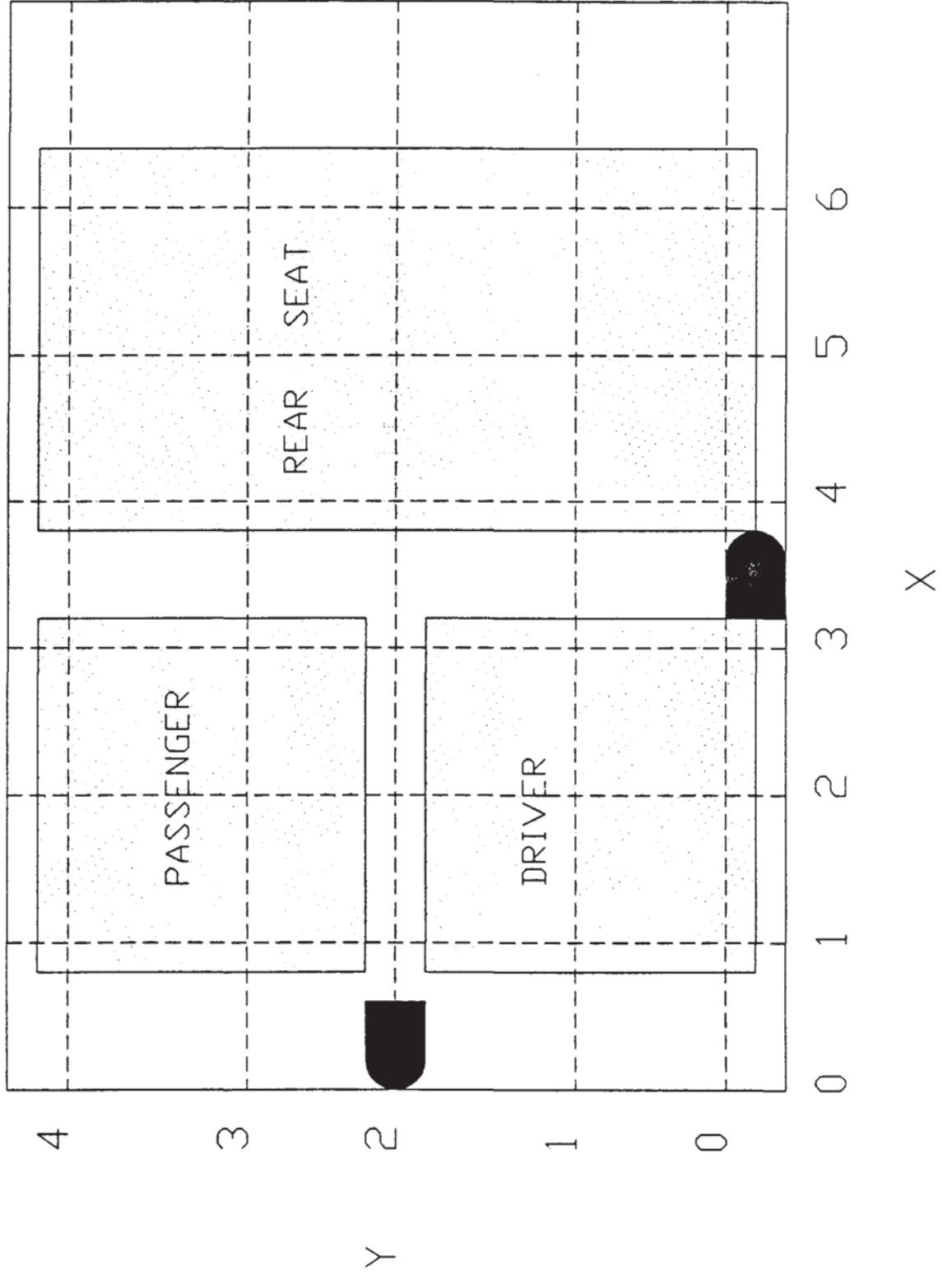

FIGURE 2 - POLICE CRUISER X,Y,Z GRID PATTERN
GRID SPACING IS 1 FOOT

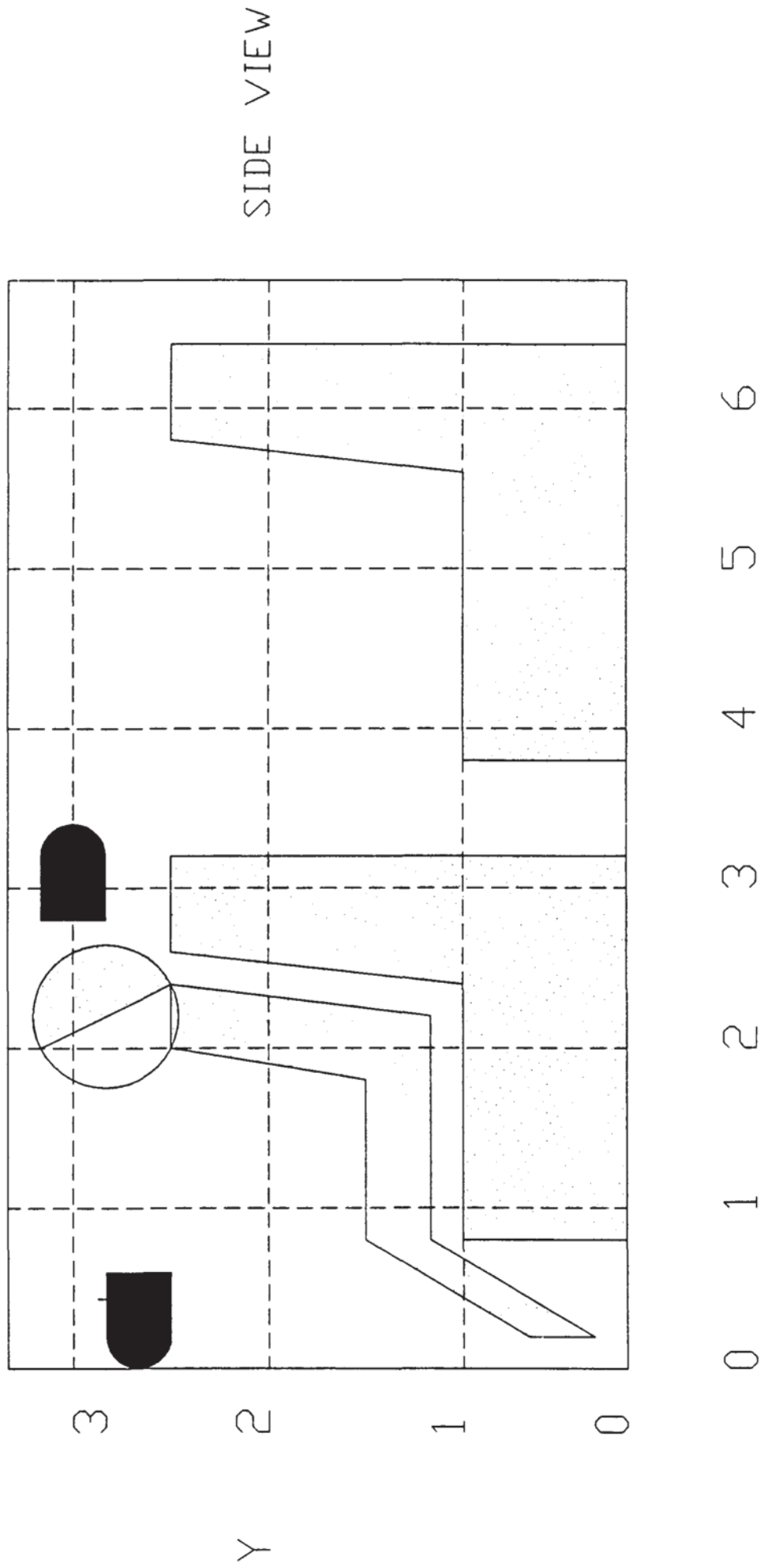
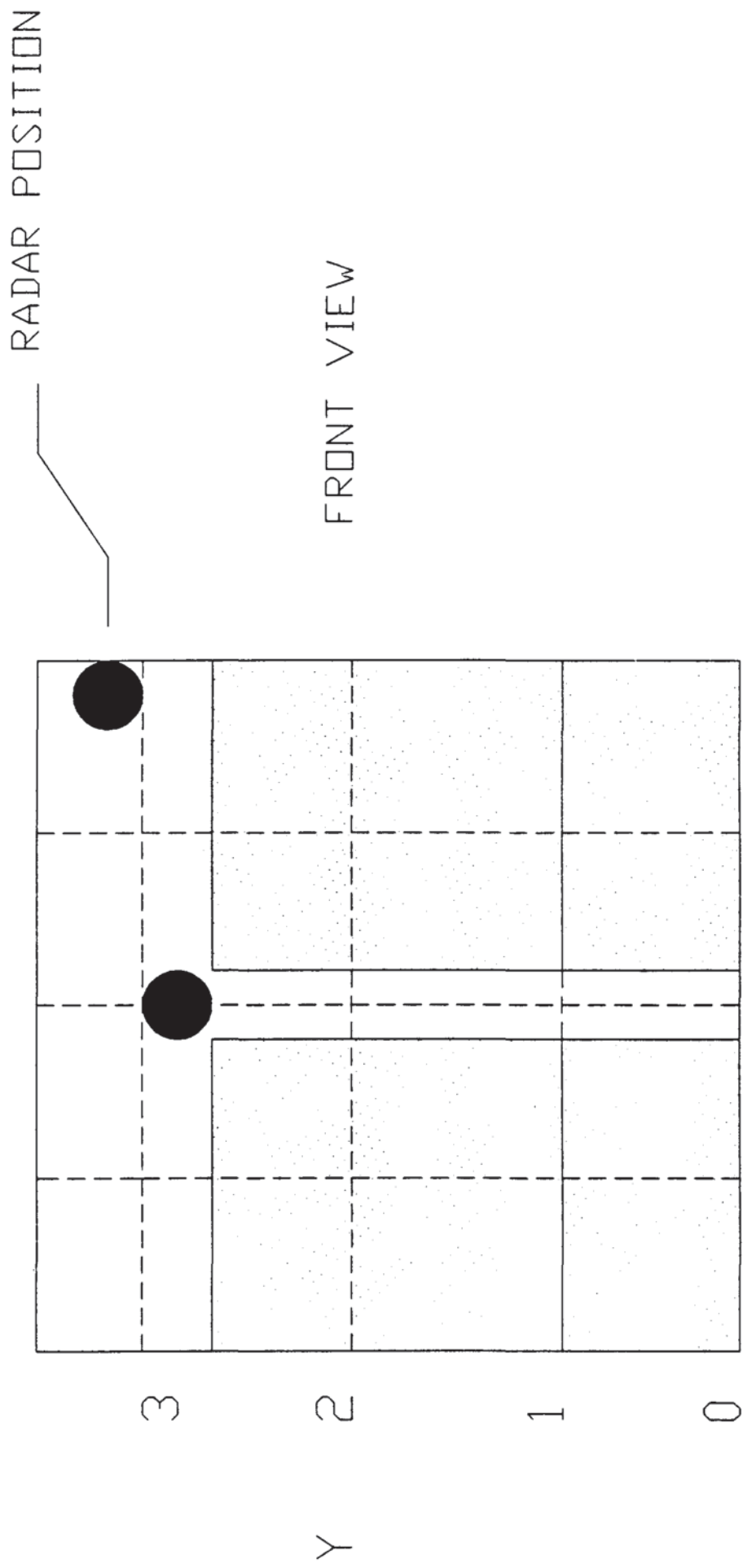

FIGURE 3 POLICE CRUISER X,Y,Z GRID PATTERN
GRID SPACING IS 1 FOOT



0 1 2 3 4

X